



# Q-Tec™ Q24A-Q60A Air Conditioners

## GREEN REFRIGERANT R-410A

### Cooling Capacities: 24,000 to 54,000 Btuh

The Q-Tec™ series self contained packaged air conditioner is designed to be installed inside a building structure against an exterior exposed wall. Q-Tec's™ design provides "whisper" quiet operation with total comfort for the occupants at efficiency levels up to 24% above the federal standard. This design eliminates the need for roof-mounted equipment and outside condensing units and can meet your specific architectural requirements.

Q-Tec's™ "quiet technology" provides extremely low sound levels (both indoor and outdoor) by using special components and materials in the construction of the unit. By using special motors, sound insulation and other sound absorbing features, we have built an air conditioner system that is significantly quieter than typical product available today.

Q-Tec™ is suitable for both new construction and renovation projects for schools, modular buildings and light commercial buildings. A variety of ventilation and dehumidification options are designed to address your project's indoor air quality and dehumidification requirements.

The Q-Tec™ Series unique design allows all maintenance and service to be performed inside the building to facilitate multi-story installations. Access to air filters and controls is accomplished through a hinged front panel for easy accessibility. All Q-Tec™ Series models are built on heavy duty permanent rollers for easy installation and removal from the wall sleeve for additional service access.

Q-Tec's™ durable, easy to clean cabinet is aesthetically pleasing and comes standard with side and bottom trim pieces. Two types of cabinet finish are available: a durable two tone (slate and platinum) vinyl covered steel, or gray pre-painted steel.

### Product Features

#### Scroll Compressor

The Copeland scroll compressor has been designed for increased efficiency, quieter operation with reduced shutdown noise and improved reliability for longer life. Eliminates need for crankcase heater and suction line accumulator.

#### Phase Rotation Monitor

Standard on all 3 phase scroll compressors. Protects against reverse rotation if power supply is not properly connected.

#### Indoor Blower Motor

All models feature a variable speed (ECM) motor providing super high efficiency, low sound levels and soft start capabilities. The motor is self-adjusting to provide the proper airflow rate at high static pressure for ducted installations without user adjustment or wiring changes. Optional dehumidification circuit (hot gas reheat) provides improved dehumidification when used with humidistat.

#### Outdoor Fan Motor

The PSC outdoor fan motor has double oil capacity sleeve bearings and is totally enclosed for extended life.

#### Copper Tube/Aluminum Fin Coils

Grooved copper tubing and enhanced aluminum fins provide maximum heat transfer and high energy efficiency. Evaporator coil constructed with hydrophilic fin stock that seals fin surface against aluminum oxide formation, is resistant to mold and mildew growth (tested to ASTM D3273, no growth), and reduces beading of condensate on the fin surface. Optional phenolic coated coils are available.

#### Cabinet

Constructed of 20 gauge pre-painted or vinyl laminated galvanized steel. Choice of either two tone vinyl finish with "slate" front panels and "platinum" cabinet for designer appearance, or gray or beige painted steel. Vinyl finish is very resistant to scratching and marring and is very easy to clean. Tamper resistant fasteners are provided for access panels. Unit includes built-in rollers for easy installation into wall sleeve and removal for service if necessary. Hinged, lockable front panel for filter service and access to primary functional electrical controls.

#### Insulation

Cabinet is fully insulated with foil covered, high density fiberglass insulation with sealed edge treatment and special sound deadening insulation material in the compressor section. All insulation is designed to resist mold and mildew growth and facilitate ease of cleaning.

#### Electrical Components

Are easily accessible for routine inspection and maintenance through front service panels. Circuit breaker standard on all 208/230V models and rotary disconnect standard on all 460V models. Circuit breaker/rotary disconnect access is through lockable access panel. Lock and key provided as standard equipment.

#### Electric Heat Strips

Backup electric heat strips feature automatic limit safety controls. Heater packages are factory installed for all models. See Electric Heat Table for available options.

- Complies with efficiency requirements of ANSI/ASHRAE/IESNA 90.1-2010.
- Certified to ANSI/ARI Standard 390-2003 for SPVU (Single Package Vertical Units).
- Intertek ETL Listed to Standard for Safety Heating and Cooling Equipment ANSI/UL 1995/CSA 22.2 No. 236-05, Fourth Edition.
- Commercial Product - Not intended for Residential application.



#### Hot Water Coil

A plenum mounted hot water coil is available for both free-blow and ducted applications.

#### Air Filters

One-inch disposable panel type air filters are standard. Optional two-inch pleated and two-inch fiberglass disposable air filters are available. Optional Energy Recovery Ventilator has a separate filter for exhaust air to keep ERV clean.

#### Refrigerant Service Ports

Located in filter compartment for easy access.

#### Liquid Filter Dryer

Standard on all models.

#### High/Low Pressure Switch

Provides refrigerant circuit high pressure and loss of charge protection. Includes lockout circuit that is resettable from room thermostat.

#### Compressor Control Module

Provides short cycle protection for the compressor, which extends compressor life.

#### Ventilation Packages

Barometric fresh air damper standard on all units and allows up to 25% outside fresh air. Optional energy recovery ventilator can provide up to 450 cfm of outside air and exhaust through the unit while maintaining indoor comfort and humidity levels. Economizer, commercial room ventilator and blank-off plate are also available.

#### Diagnostic Light

System service - indicates high or low pressure switch operation for compressor protection. Located inside control panel.

#### Stainless Steel Drain Pans

Provides extended life of the evaporator and condenser drain pans for maximum corrosion resistance.

#### Side Trim Piece Extension

Provides cabinet extension between interior wall and unit when wall thickness is between 12 inches to 14 inches. Standard feature shipped with all models. Optional trim kits for thinner walls available.

#### Wall Sleeve

Constructed of 16 gauge galvanized steel, coated with epoxy primer and a baked on polyester enamel paint, which allows it to withstand 1000 hours of salt spray tests per ASTM B117-03. Required for all models. Ordered separately.



## Capacity and Efficiency Ratings

MODELS	Q24A1	Q30A1	Q36A1	Q42A1	Q48A1	Q60A1
Cooling Capacity BTUH ①	24,000	29,800	34,600	40,000	46,000	54,000
EER ②	10.00	10.00	10.00	9.20	9.50	9.10

① Capacity is certified in accordance with ANSI/ARI Standard 390-2003.

② EER = Energy Efficiency Ratio and is certified in accordance with ANSI/ARI Standard 390-2003.

All ratings based on fresh air intake being 100% closed (no outside air introduction).

### Specifications - 2, 2½ and 3 Ton

MODELS	Q24A1-A	Q24A1-B	Q24A1-C	Q30A1-A	Q30A1-B	Q30A1-C	Q36A1-A	Q36A1-B	Q36A1-C
<b>ELECTRICAL RATING--60 HZ</b>	230/208 - 1	230/208 - 3	460 - 3	230/208 - 1	230/208 - 3	460 - 3	230/208 - 1	230/208 - 3	460 - 3
Operating Voltage Range	197-253		414-506	197-253		414-506	197-253		414-506
<b>COMPRESSOR-- CIRCUIT A</b>									
Voltage	230/208		460	230/208		460	230/208		460
Rated Load Amps	10.5/12.2	6.9/8.0	4.9	12.5/14.3	8.0/9.2	5.7	13.6/15.2	8.5/9.5	6.0
Branch Circuit Selection Current	12.9	8.4	5.2	14.3	9.2	5.7	16.7	10.5	6.0
Lock Rotor Amps	64/64	58/58	28	77/77	71/71	38	79/79	73/73	38
<b>FAN MOTOR &amp; CONDENSER</b>									
Fan Motor--HP-RPM-SPD	1/5 - 1075 - 1			1/5 - 1075 - 1			1/5 - 1075 - 1		
Fan Motor-- Volts-Amps	230/208 - 1.6		460 - .8	230/208 - 1.6		460 - .8	230/208 - 1.9		460 - 1.0
Fan--DIA-CFM	20" - 1600			20" - 1600			20" - 1750		
<b>MOTOR &amp; EVAPORATOR</b>									
Blower Motor HP-SPD	1/2 - Variable			1/2 - Variable			1/2 - Variable		
Blower Motor--Volts-Amps	230/208 - 1.8			230/208 - 2.7			230/208 - 3.7		
CFM Cooling & E.S.P. w/Filter (Rated-Wet Coil)	800 @ .1 ESP			1000 @ .15 ESP			1200 @ .15 ESP		
Filter Sizes (inches) STD.	1 - 16x20x1 + 1 - 16x16x1			1 - 16x20x1 + 1 - 16x16x1			1 - 16x20x1 + 1 - 16x16x1		
<b>SHIPPING WEIGHT--LBS.</b>	500			500			500		

### Specifications - 3½, 4 and 5 Ton

MODELS	Q42A1-A	Q42A1-B	Q42A1-C	Q48A1-A	Q48A1-B	Q48A1-C	Q60A1-A	Q60A1-B	Q60A1-C
<b>ELECTRICAL RATING--60 HZ</b>	230/208 - 1	230/208 - 3	460 - 3	230/208 - 1	230/208 - 3	460 - 3	230/208 - 1	230/208 - 3	460 - 3
Operating Voltage Range	197-253		414-506	197-253		414-506	197-253		414 - 506
<b>COMPRESSOR-- CIRCUIT A</b>									
Voltage	230/208		460	230/208		460	230/208		460
Rated Load Amps	19.0/21.2	12.6/14.0	6.5	18.1/21.1	13.1/14.7	6.5	24.6/28.6	14.6/17.0	8.5
Branch Circuit Selection Current	21.2	14.0	6.5	23.1	16.1	7.1	28.6	17.0	8.5
Lock Rotor Amps	109/109	83/83	41	134/134	91/91	46	134/134	110/110	52
<b>FAN MOTOR &amp; CONDENSER</b>									
Fan Motor--HP-RPM-SPD	1/5 - 1075 - 1			1/3 - 1100 - 1			1/3 - 1100 - 1		
Fan Motor--Volts-Amps	230/208 - 1.9		460 - 1.0	230/208 - 1.9		460 - 1.0	230/208 - 1.9		460 - 1.0
Fan--DIA-CFM	20" - 1750			20" - 1750			20" - 1750		
<b>MOTOR &amp; EVAPORATOR</b>									
Blower Motor HP-SPD	1/2 - Variable			1/2 - Variable			3/4 - Variable		
Blower Motor--Volts-Amps	230/208 - 3.7			230/208 - 3.7			230/208 - 4.9		
CFM Cooling & E.S.P. w/Filter (Rated-Wet Coil)	1200 @ .15 ESP			1400 @ .2 ESP			1550 @ .2 ESP		
Filter Sizes (inches) STD.	1 - 16x20x1 + 1 - 16x16x1			1 - 16x25x1 + 1 - 16x16x1			1 - 16x25x1 + 1 - 16x16x1		
<b>SHIPPING WEIGHT--LBS.</b>	530			560			560		

### Factory Built-in Electric Heat Table

Nominal Kw	At 240V (1)				At 208V (1)				At 480V (2)			At 460V (2)		
	Kw	1-Ph Amps	3-Ph Amps	Btuh	Kw	1-Ph Amps	3-Ph Amps	Btuh	Kw	3-Ph Amps	Btuh	Kw	3-Ph Amps	Btuh
5.0	5.0	20.8		17,065	3.75	18.0		12,799						
6.0	6.0		14.4	20,478	4.50		12.5	15,359	6.0	7.2	20,478	5.52	6.9	18,840
9.0	9.0		21.7	30,717	6.75		18.7	23,038	9.0	10.8	30,717	8.28	10.4	28,260
10.0	10.0	41.7		34,130	7.50	36.1		25,598						
12.0	12.0		28.9	40,956	9.00		25.0	30,717	12.0	14.4	40,956	11.04	13.9	37,680
15.0	15.0	62.5	36.1	51,195	11.25	54.1	31.2	38,396	15.0	18.0	51,195	13.80	17.3	47,099

(1) These electric heaters are available in 230/208V units only.

(2) These electric heaters are available in 480V units only.

## Indoor Blower Performance

Model	Rated ESP.	Max. ESP ①	Rated CFM ②	Optional CFM ③	Continuous CFM ④	Dehumidification CFM ⑤	CFM @ Max ESP
Q24A ⑥	0.10	0.5	800	N/A	800	800	700
Q30A	0.15	0.8	1000	N/A	1000	1000	910
Q36A	0.15	0.8	1200	1000	1000	1000	1175
Q42A	0.15	0.8	1200	1000	1000	1000	1175
Q48A	0.20	0.8	1400	1250	1100	1250	1175
Q60A	0.20	0.8	1550	1250	1100	1250	1400

**Note:** These units are equipped with a variable speed (ECM) indoor motor that automatically adjusts itself to maintain approximately the same rate of indoor airflow in both heating and cooling, dry and wet coil conditions and at both 230/208 or 460 volts.

① Max. ESP (inches WC) shown is with 1" thick disposable filter (reduced by .2 for 2" filter)

② Rated CFM (based on ducted application) for heating and cooling operation. To obtain full rated CFM on models Q36A, Q42A, Q48A and Q60A, refer to installation instruction supplied with unit.

③ Reduced indoor airflow option to provide lowest possible indoor air sound level. Reduces system capacity performance by approximately 2%.

④ Continuous fan CFM is the total air being circulated during continuous fan mode.

⑤ Indoor airflow during periods of high humidity when system is operating under control of optional humidistat for maximum humidity reduction.

⑥ Model Q24A -- when operating on 2nd stage heating the indoor air will increase to 1000 cfm.

## Ventilation System Packages

Q-Tec models are designed to provide optional ventilation packages to meet all of your ventilation and indoor air quality requirements. All units are equipped with a barometric fresh air damper as the standard ventilation package. All ventilation packages are factory installed.

### BAROMETRIC FRESH AIR DAMPER

#### STANDARD

The barometric fresh air damper is a standard feature on all models. It allows outside ventilation air, up to 25% of the total airflow rating of the unit, to be introduced through the air inlet openings and to be mixed with the conditioned air. The damper opens during blower operation and closes when the blower is off. Adjustable blade stops allow different amounts of outside air to be introduced into the building and can be easily locked closed if required.

### BLANK OFF PLATE

#### OPTIONAL

A blank off plate covers the air inlet openings which restricts any outside air from entering the unit. The blank off plate should be utilized in applications where outside air is not required to be mixed with the conditioned air.

**NOTE:** The above vent systems are intake only without built-in exhaust capability. Building will likely require separate field installed barometric relief or mechanical exhaust elsewhere within the conditioned space. Balancing dampers in the return air grille may be required to achieve specified amount of outdoor air intake.

### COMMERCIAL ROOM VENTILATOR

#### OPTIONAL

The built-in commercial room ventilator is internally mounted and allows outside ventilation air, up to 50% of the total airflow rating of the unit, to be introduced through the air inlet openings. It includes a built-in exhaust air damper. The commercial room ventilator (CRV) is a simple and innovative approach to improving the indoor air quality by providing fresh air intake and exhaust capability through the CRV. The damper can be easily adjusted to control the amount of fresh air supplied into the building. The CRV can be controlled by indoor blower operation or field controlled based on room occupancy. Complies with ANSI/ASHRAE Standard 62.1 "Ventilation for Acceptable Indoor Air Quality".

**Two Models Available:** Spring return on power loss or deactivation  
Power return (will not close on power loss)

### ENERGY RECOVERY VENTILATOR

#### OPTIONAL

The energy recovery ventilator (ERV) is a highly innovative approach to meeting indoor air quality ventilation requirements as established by ANSI/ASHRAE Standard 62.1. The ERV is internally mounted and allows up to 450 CFM (depending upon speed setting) of fresh air and exhaust through the unit while maintaining superior indoor comfort and humidity levels. In most cases this can be accomplished without increasing equipment sizing or operating costs. Heat transfer efficiency is up to 64% during summer and 79% during winter conditions.

The ERV consists of a unique "rotary energy recovery cassette" that provides effective sensible and latent heat transfer capabilities during summer and winter conditions. Various control schemes are addressed including limiting ventilation during building occupancy only. The ERV has a filter for the exhaust air to keep the rotary wheels clean and free of any debris introduced through the room return air grille. The intake and exhaust rates can be independently selected. Factory set on medium intake and low exhaust.

### ECONOMIZER

#### OPTIONAL

The built-in economizer system is internally mounted behind the service door and allows outdoor air to be introduced through the air inlet openings. The amount of outdoor air varies in response to the system controls and settings defined by the end user. It includes a built-in exhaust air damper. The economizer is designed to provide "free cooling" when outside air conditions are cool and dry enough to satisfy cooling requirements without running the compressor. This in turn provides lower operating costs, while extending the life of the compressor.

#### Standard Features:

- One Piece Construction - Easy to install with no mechanical linkage adjustment required.
- Exhaust Air Damper - Built in with positive closed position. Provides exhaust air capability to prevent pressurization of tight buildings.
- Actuator Motor - 24 volt, power open, spring return with built in torque limiting switch.
- Proportioning Type Control - for maximum "free cooling" economy and comfort.
- Moisture Eliminator & Prefilter - permanent, washable aluminum construction.
- Enthalpy Control - adjustable to monitor outdoor temperature and humidity.
- Minimum Position Potentiometer - adjustable to control minimum damper blade position for ventilation purposes.
- Mixed Air Sensor - to monitor outside and return air to automatically modulate damper position.

## Commercial Room Ventilator Performance Tables

**TABLE 1**

Q24A VENTILATION MODE CFM				
Damper Position	Free Blow	Static Pressure		
		0.1	0.3	0.5
A	125	120	100	75
B	135	130	115	100
C	165	160	160	140
D	255	255	235	195
E	375	320	290	265

**TABLE 2**

Q24A COOLING & HEATING MODE CFM				
Damper Position	Free Blow	Static Pressure		
		0.1	0.3	0.5
A	220	215	200	175
B	245	235	210	185
C	255	260	245	225
D	335	335	330	290
E	385	385	360	320

**TABLE 3**

Q30A Ventilation Mode CFM Q36A Ventilation Mode CFM Q42A Ventilation Mode CFM Q48A Ventilation Mode CFM				
Damper Position	Free Blow	Static Pressure		
		0.1	0.2	0.3
A	140	135	125	120
B	180	170	160	160
C	220	210	205	195
D	315	315	315	290
E	410	400	385	380

**TABLE 4**

Q30A COOLING & HEATING MODE CFM Q36A LOW SPEED COOLING & HEATING MODE CFM Q42A LOW SPEED COOLING & HEATING MODE CFM Q48A LOW APEED COOLING & HEATING MODE CFM				
Damper Position	Free Blow	Static Pressure		
		0.1	0.3	0.5
A	235	230	225	220
B	265	250	245	240
C	325	315	300	290
D	400	400	390	380
E	465	460	445	430

**TABLE 5**

Q36A HIGH SPEED COOLING & HEATING MODE CFM Q42A HIGH SPEED COOLING & HEATING MODE CFM Q48A HIGH SPEED COOLING & HEATING MODE CFM				
Damper Position	Free Blow	Static Pressure		
		0.1	0.3	0.5
A	255	250	250	230
B	285	280	280	280
C	360	360	350	345
D	445	445	445	440
E	500	500	500	490

**TABLE 6**

Q60A VENTILATION MODE CFM				
Damper Position	Free Blow	Static Pressure		
		0.1	0.3	0.5
A	185	185	180	180
B	215	215	210	200
C	290	290	280	275
D	370	370	365	350
E	465	465	455	445

**TABLE 7**

Q60A COOLING & HEATING MODE CFM				
Damper Position	Free Blow	Static Pressure		
		0.1	0.3	0.5
A	235	230	230	215
B	265	260	255	255
C	350	350	345	340
D	470	470	455	450
E	580	570	565	560

*NOTE: Ventilation airflow will increase up to 50 CFM during backup or emergency heat operation due to increased total airflow.*





# Installation Overview

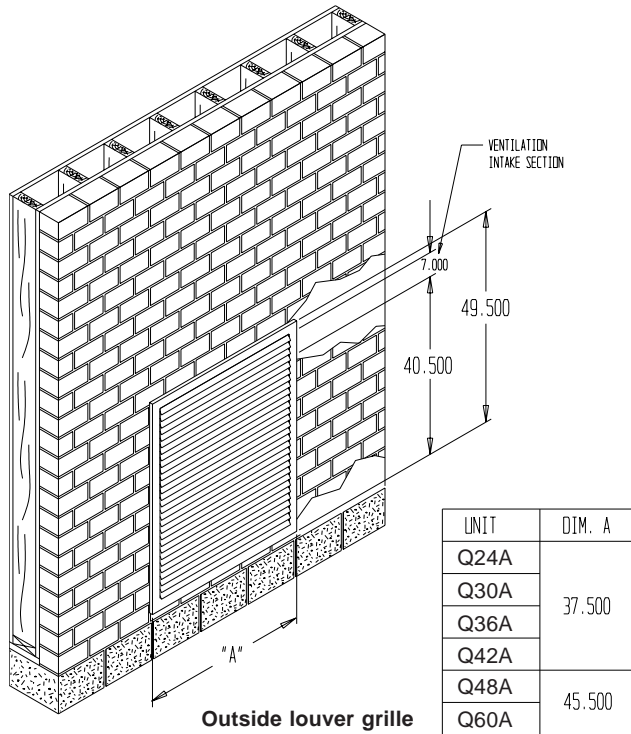

MIS-1791

HINGED FRONT PANEL FOR FILTER SERVICE AND ACCESS TO ELECTRICAL CONTROLS.

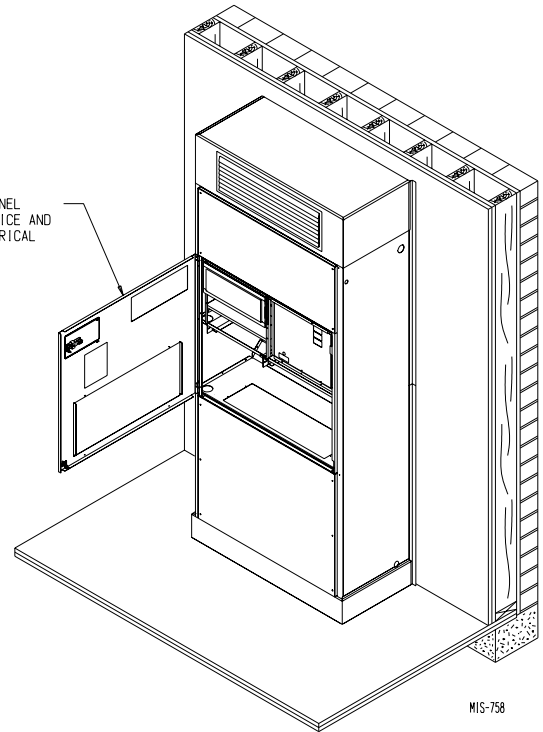

**Unit installed with free blow plenum box**

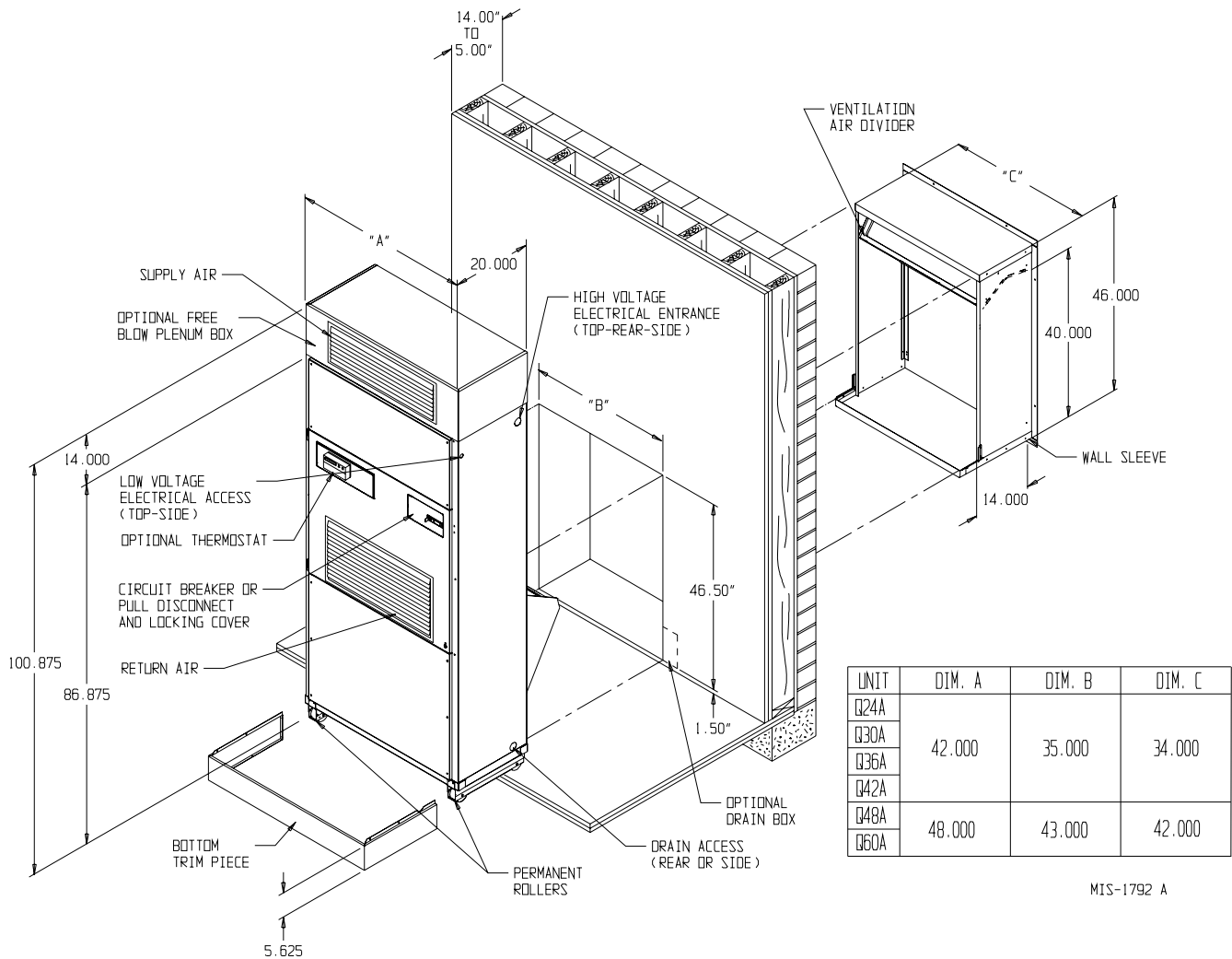

MIS-1792 A

## Dimensions of Basic Unit for Architectural and Installation Requirements (Nominal)

DIMENSION CHART					
UNIT	DIM. A	DIM. B	DIM. C	DIM. D	DIM. E
Q24A	7.625	42.000	30.000	30.000	43.000
Q30A					
Q36A					
Q42A					
Q48A	10.625	48.000	40.000	40.000	49.000
Q60A					

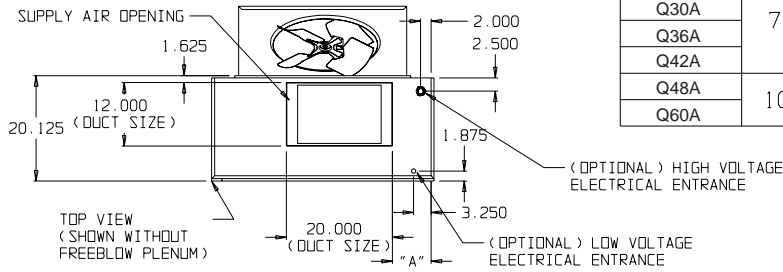

**Drawings are not to scale**

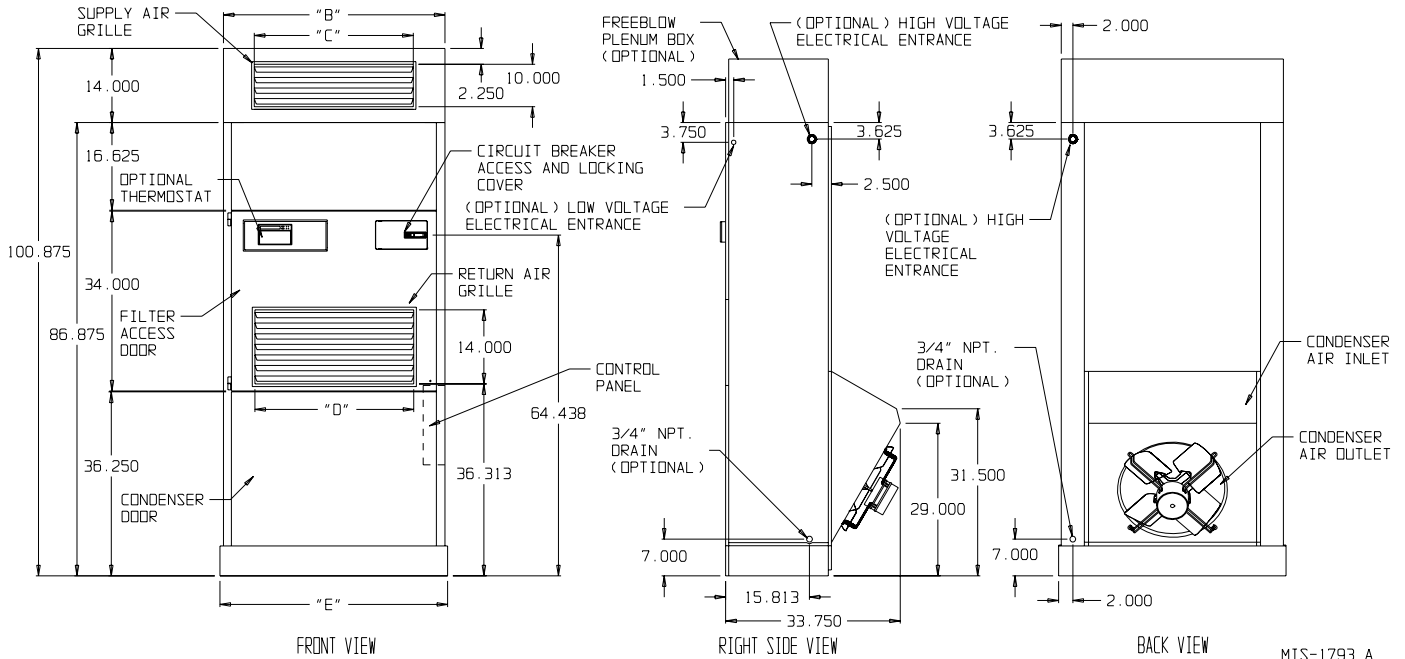

## Optional Hot Water Coil Performance - Heating Capacity @ 180°F Water & 70° Return Air

GPM	CFM									
	800	900	1000	1100	1200	1300	1400	1500	1600	1700
1.5	32,000	32,667	33,333	34,000	34,500	35,000	35,500	36,000	36,400	36,750
2	42,000	43,200	44,400	45,600	46,400	47,200	48,000	48,500	49,000	49,500
3	49,000	51,667	53,750	57,000	59,400	61,750	64,000	65,200	66,000	67,000
4	56,000	59,000	62,000	65,000	69,000	73,000	77,000	79,500	82,000	84,000
5	59,000	62,583	66,167	69,750	72,833	75,917	79,000	81,000	83,000	85,000
6	62,000	66,167	70,333	74,500	77,000	79,500	82,000	83,500	85,000	86,500
7	63,500	67,708	71,917	76,125	78,917	81,708	84,500	86,500	88,000	89,200
8	65,000	69,250	73,500	77,750	80,833	83,917	87,000	88,900	90,500	91,750
9	66,000	70,525	75,050	79,575	82,883	86,192	89,500	91,500	93,000	94,500
10	67,000	71,800	76,600	81,400	84,933	88,467	92,000	94,500	96,000	97,500

## Electrical Specifications - Standard Models

Model	Rated Volts and Phase	Single Circuit					Dual Circuit							
		No. Field Power Circuits	Ⓛ Minimum Circuit Ampacity	Ⓛ Maximum External Fuse or Ckt. Brkr.	Ⓛ Field Power Wire Size	Ⓛ Ground Wire	Ⓛ Minimum Circuit Ampacity		Ⓛ Maximum External Fuse or Ckt. Breaker		Ⓛ Field Power Wire Size		Ⓛ Ground Wire Size	
							Ckt. A	Ckt. B	Ckt. A	Ckt. B	Ckt. A	Ckt. B	Ckt. A	Ckt. B
Q24A1-A0Z	230/208-1	1	22	30	10	10	-	-	-	-	-	-	-	-
A05		1	30	30	10	10	-	-	-	-	-	-	-	-
A10		1	55	60	6	10	-	-	-	-	-	-	-	-
Q24A1-B0Z	230/208-3	1	17	20	12	12	-	-	-	-	-	-	-	-
B06		1	25	25	10	10	-	-	-	-	-	-	-	-
B09		1	33	35	8	10	-	-	-	-	-	-	-	-
Q24A1-C0Z	460-3	1	10	15	14	14	-	-	-	-	-	-	-	-
C06		1	12	15	14	14	-	-	-	-	-	-	-	-
C09		1	17	20	12	12	-	-	-	-	-	-	-	-
Q30A1-A0Z	230/208-1	1	25	35	8	10	-	-	-	-	-	-	-	-
A05		1	32	35	8	10	-	-	-	-	-	-	-	-
A10		1	57	60	6	10	-	-	-	-	-	-	-	-
Q30A1-B0Z	230/208-3	1	18	25	10	10	-	-	-	-	-	-	-	-
B06		1	25	25	10	10	-	-	-	-	-	-	-	-
B09		1	34	35	8	10	-	-	-	-	-	-	-	-
B12		1	43	45	6	10	-	-	-	-	-	-	-	-
Q30A1-C0Z	460-3	1	11	15	14	14	-	-	-	-	-	-	-	-
C06		1	14	15	14	14	-	-	-	-	-	-	-	-
C09		1	18	20	12	12	-	-	-	-	-	-	-	-
C12		1	23	25	10	10	-	-	-	-	-	-	-	-
Q36A1-A0Z	230/208-1	1	29	45	8	10	-	-	-	-	-	-	-	-
A05		1	34	45	8	10	-	-	-	-	-	-	-	-
A10		1	58	60	6	8	-	-	-	-	-	-	-	-
A15		1 or 2	84	90	4	8	58	25	60	25	6	10	10	10
Q36A1-B0Z	230/208-3	1	21	30	10	10	-	-	-	-	-	-	-	-
B06		1	26	30	10	10	-	-	-	-	-	-	-	-
B09		1	35	35	8	10	-	-	-	-	-	-	-	-
B15		1	53	60	6	10	-	-	-	-	-	-	-	-
Q36A1-C0Z	460-3	1	12	15	14	14	-	-	-	-	-	-	-	-
C06		1	14	15	14	14	-	-	-	-	-	-	-	-
C09		1	18	20	12	12	-	-	-	-	-	-	-	-
C15		1	27	30	10	10	-	-	-	-	-	-	-	-
Q42A1-A0Z	230/208-1	1	35	50	8	10	-	-	-	-	-	-	-	-
A05		1	35	50	8	10	-	-	-	-	-	-	-	-
A10		1	58	60	6	8	-	-	-	-	-	-	-	-
A15		1 or 2	83	90	4	8	58	25	60	25	6	10	10	10
Q42A1-B0Z	230/208-3	1	26	35	8	10	-	-	-	-	-	-	-	-
B06		1	26	35	8	10	-	-	-	-	-	-	-	-
B09		1	35	35	8	10	-	-	-	-	-	-	-	-
B15		1	53	60	6	10	-	-	-	-	-	-	-	-
Q42A1-C0Z	460-3	1	13	15	14	14	-	-	-	-	-	-	-	-
C06		1	14	15	14	14	-	-	-	-	-	-	-	-
C09		1	18	20	12	12	-	-	-	-	-	-	-	-
C15		1	27	30	10	10	-	-	-	-	-	-	-	-
Q48A1-A0Z	230/208-1	1	37	50	8	10	-	-	-	-	-	-	-	-
A05		1	37	50	8	10	-	-	-	-	-	-	-	-
A10		1	58	60	6	10	-	-	-	-	-	-	-	-
A15		1 or 2	83	90	4	8	58	25	60	25	8	10	10	10
Q48A1-B0Z	230/208-3	1	28	40	8	10	-	-	-	-	-	-	-	-
B06		1	28	40	8	10	-	-	-	-	-	-	-	-
B09		1	35	40	8	10	-	-	-	-	-	-	-	-
B15		1	53	60	6	10	-	-	-	-	-	-	-	-
Q48A1-C0Z	460-3	1	14	20	12	12	-	-	-	-	-	-	-	-
C06		1	14	20	12	12	-	-	-	-	-	-	-	-
C09		1	18	20	12	12	-	-	-	-	-	-	-	-
C15		1	27	30	10	10	-	-	-	-	-	-	-	-
Q60A1-A0Z	230/208-1	1	45	60	8	10	-	-	-	-	-	-	-	-
A10		1	59	60	6	10	-	-	-	-	-	-	-	-
A15		1 or 2	84	90	4	8	59	25	60	25	8	10	10	10
Q60A1-B0Z	230/208-3	1	31	45	8	10	-	-	-	-	-	-	-	-
B09		1	36	45	8	10	-	-	-	-	-	-	-	-
B15		1	55	60	6	10	-	-	-	-	-	-	-	-
Q60A1-C0Z	460-3	1	16	20	12	12	-	-	-	-	-	-	-	-
C09		1	19	20	12	12	-	-	-	-	-	-	-	-
C15		1	28	30	10	10	-	-	-	-	-	-	-	-

① Maximum size of the time delay fuse or HACR type circuit breaker for protection of field wiring conductors.

② Based on 75°C copper wire. All wiring must conform to the National Electrical Code and all local codes.

③ These "Minimum Circuit Ampacity" values are to be used for sizing the field power conductors. Refer to the National Electric Code (latest revision), article 310 for power conductor sizing.

**CAUTION:** When more than one field power conductor circuit is run through one conduit, the conductors must be derated. Pay special attention to note 8 of table 310 regarding Ampacity Adjustment Factors when more than three conductors are in a raceway.



## Electrical Specifications - Dehumidification Models

Model	Rated Volts and Phase	Single Circuit					Dual Circuit							
		No. Field Power Circuits	③ Minimum Circuit Ampacity	① Maximum External Fuse or Ckt. Brkr.	② Field Power Wire Size	④ Ground Wire	③ Minimum Circuit Ampacity		① Maximum External Fuse or Ckt. Breaker		② Field Power Wire Size		④ Ground Wire Size	
							Ckt. A	Ckt. B	Ckt. A	Ckt. B	Ckt. A	Ckt. B	Ckt. A	Ckt. B
Q24A1DA0Z	230/208-1	1	22	30	10	10	-	-	-	-	-	-	-	-
A05		1	30	30	10	10	-	-	-	-	-	-	-	-
A10		1	55	60	6	10	-	-	-	-	-	-	-	-
Q24A1DB0Z	230/208-3	1	17	20	12	12	-	-	-	-	-	-	-	-
B06		1	25	25	10	10	-	-	-	-	-	-	-	-
B09		1	33	35	8	10	-	-	-	-	-	-	-	-
Q24A1DC0Z	460-3	1	10	15	14	14	-	-	-	-	-	-	-	-
C06		1	12	15	14	14	-	-	-	-	-	-	-	-
C09		1	17	20	12	12	-	-	-	-	-	-	-	-
Q30A1DA0Z	230/208-1	1	25	35	8	10	-	-	-	-	-	-	-	-
A05		1	32	35	8	10	-	-	-	-	-	-	-	-
A10		1	57	60	6	10	-	-	-	-	-	-	-	-
Q30A1DB0Z	230/208-3	1	18	25	10	10	-	-	-	-	-	-	-	-
B06		1	25	25	10	10	-	-	-	-	-	-	-	-
B09		1	34	35	8	10	-	-	-	-	-	-	-	-
B12		1	43	45	6	10	-	-	-	-	-	-	-	-
Q30A1DC0Z	460-3	1	11	15	14	14	-	-	-	-	-	-	-	-
C06		1	14	15	14	14	-	-	-	-	-	-	-	-
C09		1	18	20	12	12	-	-	-	-	-	-	-	-
C12		1	23	25	10	10	-	-	-	-	-	-	-	-
Q36A1DA0Z	230/208-1	1	29	45	8	10	-	-	-	-	-	-	-	-
A05		1	34	45	8	10	-	-	-	-	-	-	-	-
A10		1	58	60	6	8	-	-	-	-	-	-	-	-
A15		1 or 2	84	90	4	8	58	25	60	25	6	10	10	10
Q36A1DB0Z	230/208-3	1	21	30	10	10	-	-	-	-	-	-	-	-
B06		1	26	30	10	10	-	-	-	-	-	-	-	-
B09		1	35	35	8	10	-	-	-	-	-	-	-	-
B15		1	53	60	6	10	-	-	-	-	-	-	-	-
Q36A1DC0Z	460-3	1	12	15	14	14	-	-	-	-	-	-	-	-
C06		1	14	15	14	14	-	-	-	-	-	-	-	-
C09		1	18	20	12	12	-	-	-	-	-	-	-	-
C15		1	27	30	10	10	-	-	-	-	-	-	-	-
Q42A1DA0Z	230/208-1	1	35	50	8	10	-	-	-	-	-	-	-	-
A05		1	35	50	8	10	-	-	-	-	-	-	-	-
A10		1	58	60	6	8	-	-	-	-	-	-	-	-
A15		1 or 2	83	90	4	8	58	25	60	25	6	10	10	10
Q42A1DB0Z	230/208-3	1	26	35	8	10	-	-	-	-	-	-	-	-
B06		1	26	35	8	10	-	-	-	-	-	-	-	-
B09		1	35	35	8	10	-	-	-	-	-	-	-	-
B15		1	53	60	6	10	-	-	-	-	-	-	-	-
Q42A1DC0Z	460-3	1	13	15	14	14	-	-	-	-	-	-	-	-
C06		1	14	15	14	14	-	-	-	-	-	-	-	-
C09		1	18	20	12	12	-	-	-	-	-	-	-	-
C15		1	27	30	10	10	-	-	-	-	-	-	-	-
Q48A1DA0Z	230/208-1	1	37	50	8	10	-	-	-	-	-	-	-	-
A05		1	37	50	8	10	-	-	-	-	-	-	-	-
A10		1	58	60	6	10	-	-	-	-	-	-	-	-
A15		1 or 2	83	90	4	8	58	25	60	25	8	10	10	10
Q48A1DB0Z	230/208-3	1	28	40	8	10	-	-	-	-	-	-	-	-
B06		1	28	40	8	10	-	-	-	-	-	-	-	-
B09		1	35	40	8	10	-	-	-	-	-	-	-	-
B15		1	53	60	6	10	-	-	-	-	-	-	-	-
Q48A1DC0Z	460-3	1	14	20	12	12	-	-	-	-	-	-	-	-
C06		1	14	20	12	12	-	-	-	-	-	-	-	-
C09		1	18	20	12	12	-	-	-	-	-	-	-	-
C15		1	27	30	10	10	-	-	-	-	-	-	-	-
Q60A1DA0Z	230/208-1	1	45	60	8	10	-	-	-	-	-	-	-	-
A10		1	59	60	6	10	-	-	-	-	-	-	-	-
A15		1 or 2	84	90	4	8	59	25	60	25	8	10	10	10
Q60A1DB0Z	230/208-3	1	31	45	8	10	-	-	-	-	-	-	-	-
B09		1	36	45	8	10	-	-	-	-	-	-	-	-
B15		1	55	60	6	10	-	-	-	-	-	-	-	-
Q60A1DC0Z	460-3	1	16	20	12	12	-	-	-	-	-	-	-	-
C09		1	19	20	12	12	-	-	-	-	-	-	-	-
C15		1	28	30	10	10	-	-	-	-	-	-	-	-

① Maximum size of the time delay fuse or HACR type circuit breaker for protection of field wiring conductors.

② Based on 75°C copper wire. All wiring must conform to the National Electrical Code and all local codes.

③ These "Minimum Circuit Ampacity" values are to be used for sizing the field power conductors. Refer to the National Electric Code (latest revision), article 310 for power conductor sizing.

**CAUTION:** When more than one field power conductor circuit is run through one conduit, the conductors must be derated. Pay special attention to note 8 of table 310 regarding Ampacity Adjustment Factors when more than three conductors are in a raceway.

## Cooling Application Data - Outdoor Temperature °F ①

Model	D.B./ W.B.②	COOLING CAPACITY	75°	80°	85°	90°	95°	100°	105°	110°	115°
Q24A1	75/	Total Cooling	26,600	24,800	23,400	22,100	20,900	20,100	19,400	19,000	18,600
	62	Sensible Cooling	19,300	18,700	18,100	17,600	17,200	16,800	16,600	16,400	16,200
	80/	Total Cooling	28,400	27,000	25,900	24,900	24,000	23,400	22,900	22,600	22,400
	67	Sensible Cooling	18,700	18,300	17,900	17,600	17,300	17,100	17,000	16,900	16,800
	85/	Total Cooling	33,900	31,600	29,800	28,100	26,700	25,600	24,700	24,100	23,600
	72	Sensible Cooling	19,200	18,600	18,000	17,500	17,000	16,600	16,200	15,900	15,500
Q30A1	75/	Total Cooling	30,600	29,300	28,200	27,100	26,000	25,000	24,000	23,100	22,100
	62	Sensible Cooling	23,200	22,700	22,200	21,700	21,200	20,800	20,300	19,900	19,400
	80/	Total Cooling	32,600	31,900	31,300	30,600	29,800	29,100	28,300	27,500	26,600
	67	Sensible Cooling	22,500	22,200	22,000	21,700	21,400	21,100	20,800	20,500	20,200
	85/	Total Cooling	38,900	37,300	36,000	34,600	33,100	31,900	30,500	29,300	28,000
	72	Sensible Cooling	23,100	22,600	22,100	21,600	21,000	20,400	19,900	19,200	18,600
Q36A1	75/	Total Cooling	34,900	33,700	32,500	31,300	30,200	29,000	27,800	26,700	25,500
	62	Sensible Cooling	26,800	26,300	25,900	25,400	24,900	24,400	23,800	23,200	22,700
	80/	Total Cooling	37,200	36,700	36,100	35,400	34,600	33,800	32,800	31,800	30,700
	67	Sensible Cooling	26,000	25,800	25,600	25,400	25,100	24,800	24,400	24,000	23,600
	85/	Total Cooling	44,300	42,900	41,500	40,000	38,500	37,000	35,400	33,900	32,300
	72	Sensible Cooling	26,700	26,200	25,700	25,300	24,600	24,000	23,300	22,500	21,800
Q42A1	75/	Total Cooling	40,400	39,000	37,600	36,200	34,800	33,600	32,300	31,000	29,800
	62	Sensible Cooling	29,500	29,000	28,500	27,800	27,300	26,600	26,000	25,400	24,700
	80/	Total Cooling	43,100	42,500	41,700	40,900	40,000	39,100	38,100	37,000	35,800
	67	Sensible Cooling	28,600	28,400	28,200	27,800	27,500	27,100	26,700	26,200	25,700
	85/	Total Cooling	51,400	49,700	47,900	46,200	44,500	42,800	41,100	39,400	37,600
	72	Sensible Cooling	29,300	28,800	28,400	27,600	27,000	26,200	25,500	24,600	23,700
Q48A1	75/	Total Cooling	46,900	45,100	43,300	41,700	40,100	38,600	37,200	35,900	34,700
	62	Sensible Cooling	34,400	33,500	32,700	31,900	31,200	30,600	29,800	29,200	28,700
	80/	Total Cooling	50,100	49,100	48,100	47,100	46,000	45,000	43,900	42,800	41,700
	67	Sensible Cooling	33,300	32,800	32,400	31,900	31,500	31,100	30,600	30,200	29,800
	85/	Total Cooling	59,700	57,400	55,300	53,200	51,100	49,200	47,300	45,500	43,800
	72	Sensible Cooling	34,100	33,300	32,600	31,700	30,900	30,100	29,200	28,300	27,500
Q60A1	75/	Total Cooling	53,400	52,200	50,800	49,100	47,000	44,800	42,200	39,400	36,400
	62	Sensible Cooling	38,500	38,300	37,800	37,000	36,000	34,600	33,100	31,200	29,000
	80/	Total Cooling	57,000	56,900	56,400	55,500	54,000	52,200	49,800	47,000	43,800
	67	Sensible Cooling	37,300	37,500	37,400	37,000	36,300	35,200	33,900	32,200	30,200
	85/	Total Cooling	67,900	66,500	64,800	62,700	60,000	57,100	53,700	50,000	46,000
	72	Sensible Cooling	38,200	38,100	37,600	36,800	35,600	34,100	32,300	30,200	27,800

① Below 65°F, unit requires a factory or field installed low ambient control.

② Return air temp. °F.

## QSP-Series Sound Plenum

The QSP3 - QSP5 Series Sound Plenum has been designed for use with ALL Bard Q-Tec Series units, both Generation I and Generation II systems. Installation is quick and easy with removal/replacement of six existing screws from the unit cabinet. Once installed the sound plenum enhances the current quiet operation of the Q-Tec Series units, and the hinged door with cam locks provides easy access to the basic Q-Tec system. Model selection is based on equipment cabinet size and finish.

Sound Plenum Pt#	Cabinet Finish	Equipment Selection
QSP3-X	Painted Steel - Beige	Q24A - Q42A
QSP3-4	Painted Steel - Gray	Q24A - Q42A
QSP3-V	Texture Vinyl ①	Q24A - Q42A
QSP5-X	Painted Steel - Beige	Q48A - Q60A
QSP5-4	Painted Steel - Gray	Q48A - Q60A
QSP5-V	Texture Vinyl ①	Q48A - Q60A

① Front Panels Slate Finish, Side Panels Platinum Gray matching Q-tec vinyl cabinet finishes.

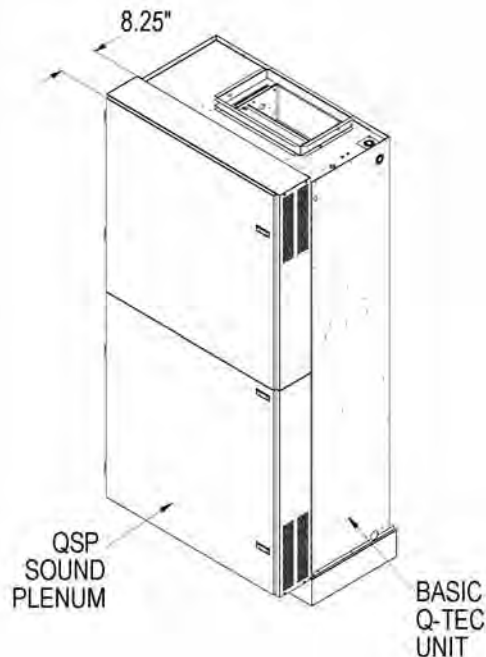

### Features:

- Two Plenum Finishes To Match Unit Cabinets
  - Vinyl or Painted Steel
- Compatible With New or Existing Units
- Removable Cam Lock Hinge Doors
- Easy Unit Service Access
- Sound Absorbing Insulation
- Reduces Equipment dBA Operating Levels
  - Up to 5 dBA with Energy Recovery Ventilator option.
  - Provides general muffling of basic unit operation. Actual sound reduction may vary depending on system operating conditions and other site variables.

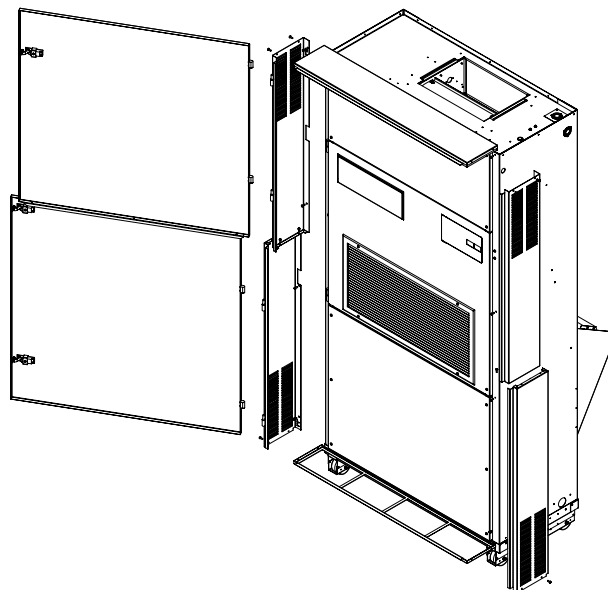

MIS-2267

# Q-Tec™ Model Nomenclature

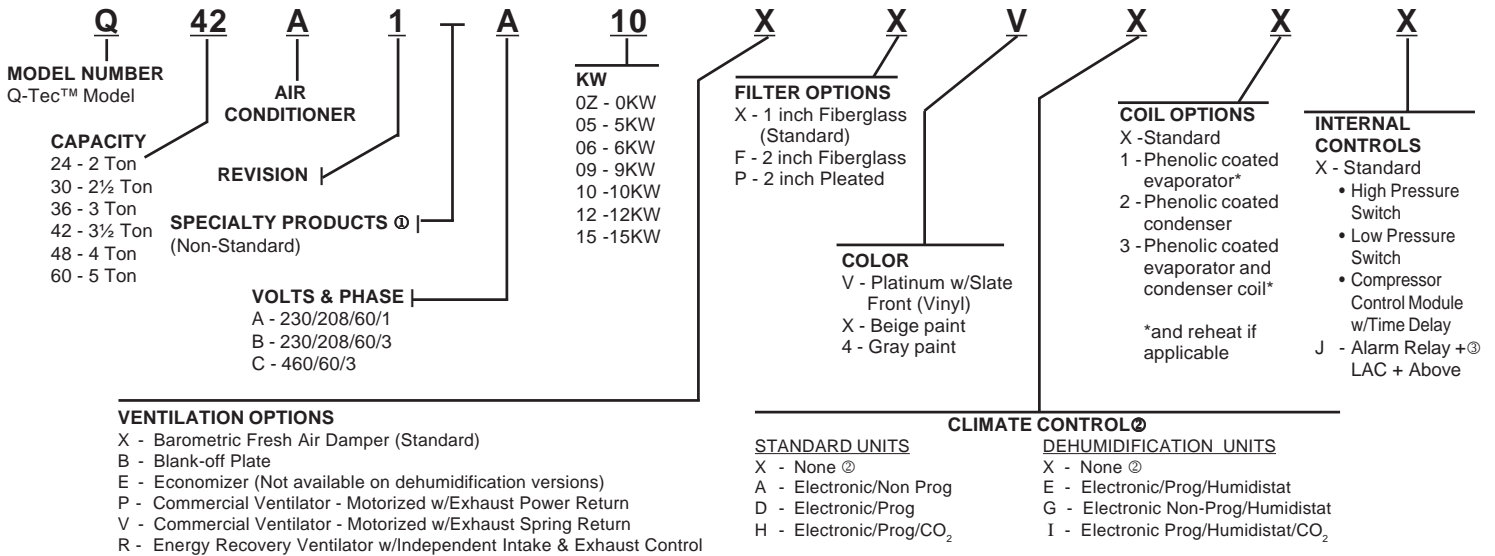

**NOTE:** Ⓣ Insert "D" for dehumidification with hot gas reheat. Reference 7960-584 for complete details.  
 Ⓣ If "X" control option is selected, then thermostat and humidistat, if applicable, or DDC control system must be field supplied.  
 Ⓣ Not available for Q\*\*A1"D" dehumidification models.

## Required Field Installed Accessories - One Size/Color Must Be Used For Each Installation

**Outdoor Louver Grilles:**

QLG-10 (for 2 - 3½ Ton Models)	QLG-15 (for 4 - 5 Ton Models)	Clear Anodized Aluminum
QLG-20 (for 2 - 3½ Ton Models)	QLG-25 (for 4 - 5 Ton Models)	Medium Bronze Anodized Aluminum
QLG-30 (for 2 - 3½ Ton Models)	QLG-35 (for 4 - 5 Ton Models)	Dark Bronze Anodized Aluminum

**Wall Sleeves: Note - Maximum dimension in inches of wall is shown ( )**

For all 2 through 3½ ton units	QWS42A (14")	QWS42A-16 (16")	QWS42A-19 (19")	QWS42A-20 (20")	QWS42A-23 (23")	QWS42A-30 (30")
For all 4 through 5 ton units	QWS48A (14")	QWS48A-16 (16")	QWS48A-19 (19")	QWS48A-20 (20")	QWS48A-23 (23")	QWS48A-30 (30")

## Optional Field Installed Accessories - Additional Items As Determined By Job Specifications

**Drain Kit:**

QCDS48A	Rear condensate drain system allows easy removal of unit from wall sleeve. <b>Fits all models.</b>
---------	--

**NOTE:** The following accessory items must be selected so that the finish (color) is matched to the Q\*\*A-model that they will be used with.

**Side Trim Extension Kits:**  
Required when wall thickness is less than 10½ inches and works for walls down to 6-inches thick. Used in place of standard trim kit supplied with unit to cover the space between unit and wall.

Model	Finish	Unit Compatibility
QSTX42A-V	Platinum vinyl	All models
QSTX42A-4	Gray paint	
QSTX42A-X	Beige paint	

**Free-Blow Plenum Boxes:**

Model	Finish	Unit Compatibility
QPB42-V	Platinum vinyl	2 - 3½ Ton
QPB42-X	Beige paint	
QPBS42-V	Platinum vinyl	2 - 3½ Ton
QPBS42-X	Beige paint	
QPB48-V	Platinum vinyl	4 - 5 Ton
QPB48-X	Beige paint	
QPBS48-V	Platinum vinyl	4 - 5 Ton
QPBS48-X	Beige paint	

**Top Fill Systems for Finishing Plenum Boxes to Ceilings:**

Model	Finish	Unit Compatibility
QPBX42-9-V	Platinum vinyl	2 - 3½ Ton
QPBX42-9-X	Beige paint	
QPBX42-10-V	Platinum vinyl	2 - 3½ Ton
QPBX42-10-X	Beige paint	
QPBX48-9-V	Platinum vinyl	4 - 5 Ton
QPBX48-9-X	Beige paint	
QPBX48-10-V	Platinum vinyl	4 - 5 Ton
QPBX48-10-X	Beige paint	

**Cabinet Extensions for Ducted Applications:**

Model	Finish	Unit Compatibility
QCX10A-V	Platinum vinyl	2 - 3½ Ton
QCX10A-X	Beige paint	
QCX15A-V	Platinum vinyl	4 - 5 Ton
QCX15A-X	Beige paint	

**Hot Water Coils with Plenum Boxes:**

Model	Finish	Unit Compatibility
QPBHW42-F-V	Platinum vinyl	2 - 3½ Ton
QPBHW42-F-X	Beige paint	
QPBHW48-F-V	Platinum vinyl	4 - 5 Ton
QPBHW48-F-X	Beige paint	
QPBHW42-D-V	Platinum vinyl	2 - 3½ Ton
QPBHW42-D-X	Beige paint	
QPBHW48-D-V	Platinum vinyl	4 - 5 Ton
QPBHW48-D-X	Beige paint	

**NOTE:** The same top fill system and cabinet extensions can be used with hot water coil plenum boxes as with standard plenum boxes.



Bard Manufacturing Company, Inc.  
Bryan, Ohio 43506  
www.bardhvac.com

**Due to our continuous product improvement policy, all specifications subject to change without notice.**

Before purchasing this appliance, read important energy cost and efficiency information available from your retailer.

**Form No. S3411 April, 2013**

Supersedes S3411-510