**WG - SERIES
COMBINATION GAS/ELECTRIC
WALL-MOUNT
INSTALLATION INSTRUCTIONS WITH DEMHUMIDIFICATION CIRCUIT**

**MODELS:
WG421D WG481D WG601D**

 **WARNING**

READ ALL INSTRUCTIONS CAREFULLY BEFORE BEGINNING THE INSTALLATION.

THE INSTALLATION MUST COMPLY WITH THESE INSTRUCTIONS AND THE REQUIREMENTS OF ALL GOVERNING CODES AND ORDINANCES FOR THE INSTALLATION LOCATION.

IT IS THE RESPONSIBILITY OF INSTALLER TO KNOW AND UNDERSTAND ALL OF THESE REQUIREMENTS.

FAILURE TO DO SO COULD CREATE A HAZARD RESULTING IN PROPERTY DAMAGE, BODILY INJURY, OR DEATH.



Bard Manufacturing Company
Bryan, Ohio 43506
Since 1914...Moving ahead, just as planned.

Manual No.: 2100-376
Supersedes:
File: Volume III, Tab 20
Date: 05-03-01

CONTENTS

| | Page | | Page |
|---|-------------|---|-------------|
| Getting Other Information and Publications | 1 | 20. Checking Gas Input Rate | 20 |
| WG Series Model Nomenclature | 2 | 21. Standard Orifice Sizing & High Altitude Derate . | 21 |
| Ventilation Options | 2 | 22. Conversion of Gas Input BTUH From High to Low Rating | 24 |
| Air Conditioning Module Options | 3 | 23. Measuring Air Temperature Rise | 24 |
| 1. Important | 3 | 24. Filters | 25 |
| 2. Application | 3 | 25. Compressor Control Module | 25 |
| 3. Duct Work | 3 | 26. Lighting & Shutdown Instructions | 26 |
| 4. High Altitude Applications | 6 | 27. Service Agency Procedures | 27 |
| 5. Transportation Damage | 6 | 28. Maintaining Unit in Good Working Order | 27 |
| 6. Installation | 6 | 29. Replacement Parts | 28 |
| 7. Wall Mounting | 7 | 30. Sequence of Operation – Heating | 29 |
| 8. Mounting the Unit | 7 | 31. Sequence of Operation – Cooling | 29 |
| 9. Clearances | 13 | 32. Indoor Blower Operation | 31 |
| 10. Vent Terminal and Combustion Inlet Hood | 13 | 33. Pressure Service Ports | 37 |
| 11. Optional Vertical Venting | 13 | 34. Refrigerant Charge | 37 |
| 12. Vent Resizing Instructions | 13 | 35. Fan Blade Setting Dimensions | 39 |
| 13. Fresh Air Intake | 14 | 36. Low NOx Burner Assembly "N" Suffix Models Only – U.S. Installations Only | 39 |
| 14. Condensate Drain | 14 | Wiring Diagrams | 42 - 53 |
| 15. Wiring – Main Power | 14 | | |
| 16. Wiring – Low Voltage Wiring | 16 | | |
| 17. Thermostats | 16 | | |
| 18. Gas Supply & Piping | 19 | | |
| 19. Manifold Pressure Adjustment | 20 | | |

CONTENTS

| | Page | | Page |
|----------------|---|---------------|---|
| FIGURES | | TABLES | |
| Figure 1 | Unit Dimensions 5 | Table 1 | Specifications 4 |
| Figure 2 | Vent Terminal & Combustion Air Intake 8 | Table 2 | Minimum Installation Clearances 13 |
| Figure 3 | Internal Filter Access Through Upper Service Door 8 | Table 3 | Thermostat Wire Size 16 |
| Figure 4 | Mounting Instructions 9 | Table 4 | Wall Thermostat & Subbase Combinations 16 |
| Figure 5 | Combustible Clearance 10 | Table 5 | Length of Standard Pipe Threads 19 |
| Figure 6 | Wall Mounting Instructions 11 | Table 6 | Gas Pipe Sizes – Natural Gas 19 |
| Figure 7 | Wall Mounting Instructions 11 | Table 7 | High Altitude Derate Charts – U.S. Installations Only 22 |
| Figure 8 | Common Wall Mounting Installations ... 12 | Table 8 | High Altitude Derate Charts – Canadian Installations Only 23 |
| Figure 9 | Fresh Air Damper 14 | Table 9 | WG421 Indoor Blower Performance 33 |
| Figure 10 | Installation of Flexible Conduit 15 | Table 10 | WG482 Indoor Blower Performance 34 |
| Figure 11 | Low Voltage Wiring 17 | Table 11 | WG601 Indoor Blower Performance 35 |
| Figure 12 | Gas Pipe Connection 18 | Table 12 | Integrated Furnace & Blower Control Operation 36 |
| Figure 13 | Proper Piping Practice 19 | Table 13 | Cooling Pressure Table 37 |
| Figure 14 | Lighting & Shutdown Instruction Label . 26 | Table 14 | Fan Blade Dimension 39 |
| Figure 15 | Top View of Gas Control 27 | Table 15 | Application Data WG421DA 40 |
| Figure 16 | Sequence of Operation – Electronic Blower Control 30 | Table 16 | Application Data WG481DA 40 |
| Figure 17 | Furnace Control Board & Blower Control 31 | Table 17 | Application Data WG601DA 41 |
| Figure 18 | 460V Blower Motor Wiring Options 32 | | |
| Figure 19 | Low Voltage Wiring 24V Terminal Block 38 | | |
| Figure 20 | Circuit Diagrams 38 | | |
| Figure 21 | Fan Blade 39 | | |
| Figure 22 | Low NOx Insert 39 | | |

Getting Other Information and Publications

These publications can help you install the furnace. You can usually find these at your local library or purchase them directly from the publisher. Be sure to consult current edition of each standard.

National Fuel Gas Code ANSI Z223.1 / NFPA 54

National Electrical Code ANSI / NFPA 70

Standard for the Installation ANSI / NFPA 90A
of Air Conditioning and
Ventilating Systems

Standard for Warm Air ANSI / NFPA 90B
Heating and Air Conditioning
Systems

Standard for Chimneys, NFPA 211
Fireplaces, Vents, and Solid
Fuel Burning Appliances

Load Calculation for ACCA Manual J
Residential Winter and
Summer Air Conditioning

Duct Design for Residential ACCA Manual D
Winter and Winter Air Conditioning
and Equipment Selection

Canadian Electrical Code CSA C22.1

For more information, contact these publishers:

ACCA **Air Conditioning Contractors of America**
1712 New Hampshire Avenue, NW
Washington, DC 20009
Telephone: (202) 483-9370

ANSI **American National Standards Institute**
11 West Street, 13th Floor
New York, NY 10036
Telephone: (212) 642-4900
Fax: (212) 302-1286

ASHRAE **American Society of Heating Refrigerating,
and Air Conditioning Engineers, Inc.**
1791 Tullie Circle, NE.
Atlanta, GA 30329-2305
Telephone: (404) 636-8400
Fax: (404) 321-5478

NFPA **National Fire Protection Association**
Batterymarch Park
P.O. Box 9101
Quincy, MA 02269-9901
Telephone: (800) 344-3555
Fax: (617) 984-7057

CSA **Canadian Standards Association**
178 Rexdale Boulevard
Rexdale, Ontario
Canada. M9W 1R3
Telephone: (416) 447-4044

COPYRIGHT MAY 2001
BARD MANUFACTURING COMPANY
BRYAN, OHIO 43506 USA

Manufactured under the following U.S. patent numbers:
5,485,878; 5,002,116; 4,924,934; 4,875,520; 4,4825,936; 4,432,409

WALL MOUNT GAS/ELECTRIC GENERAL

MODEL NUMBER NOMENCLATURE

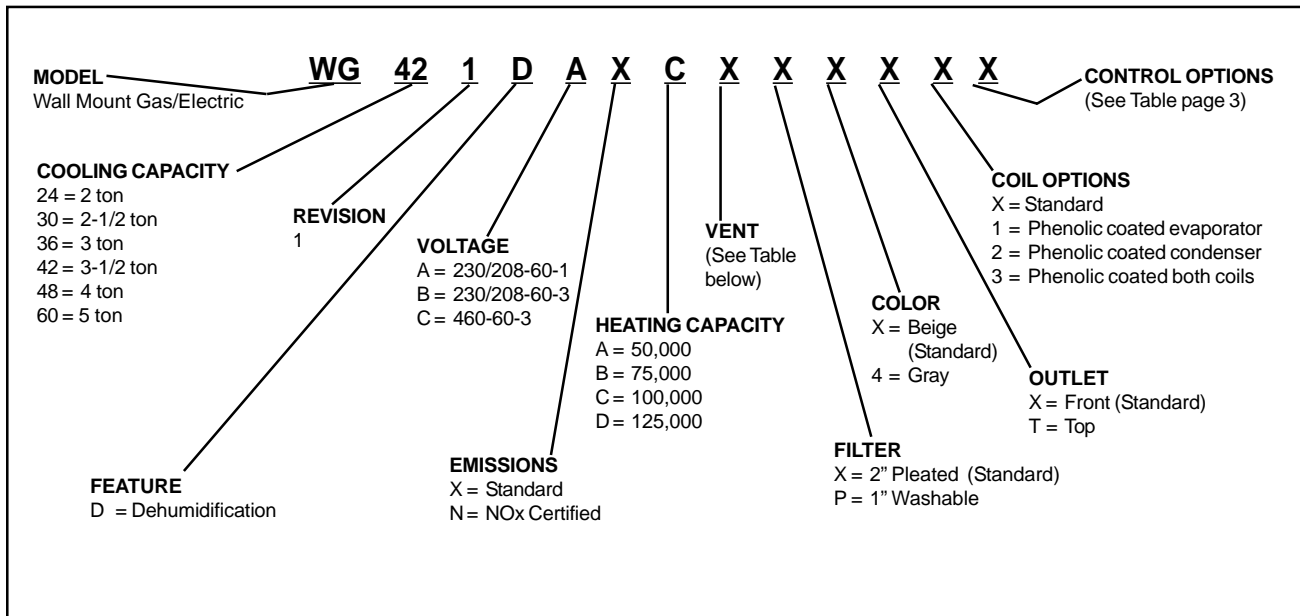

VENTILATION OPTIONS

| Description | WG421, WG481, WG601 | |
|---------------------------------------|----------------------------|----------------------------|
| | Factory Installed Code No. | Factory Installed Part No. |
| Barometric Fresh Air Damper | X | WGFAD-5 |
| Blank-Off Plate | B | WGBOP-5 |
| Motorized Fresh Air Damper | M | WGMFAD-5 |
| Commercial Ventilator - Spring Return | V | WGCRVS-5 |
| Commercial Ventilator - Power Return | P | WGCRVP-5 |
| Energy Recovery Ventilator - 230 Volt | R | WGERV-A5 |
| Energy Recovery Ventilator - 460 Volt | R | WGERV-C5 |

AIR CONDITIONING MODULE OPTIONS

| CCM ① | HPC ② | LPC ③ | Factory Installed Code | Field Installed Part |
|-------|-------|-------|------------------------|----------------------|
| STD | STD | • | G | CMA-16 |

STD = Standard equipment.

- ① CCM Compressor control module has adjustable 30 second to 5 minute delay-on-break timer. On initial power up, or any time the power is interrupted, the delay-on-make will be 2 minutes plus 10% of the delay-on-break setting. There is no delay-on-make during routine operation of the unit. The module also provides the lockout feature (with 1 retry) for high and/or low pressure controls, and a 2 minute timed bypass for low pressure control.
- ② HPC High pressure control is auto reset. Always used with compressor control module (CCM) which is included. See note ①.
- ③ LPC Low pressure control is auto reset. Always used with compressor control module (CCM) which is included. See note ①.

1. IMPORTANT

The equipment covered in this manual is to be installed by trained, experienced service and installation technicians. All duct work or portions thereof not in the conditioned space should be properly insulated in order to both conserve energy and prevent condensation or moisture damage.

2. APPLICATION

This is a fan-assisted forced air gas furnace with electric air conditioning for outdoor installation. A fan-assisted furnace is equipped with an integral mechanical means to draw products of combustion through the combustion chamber and heat exchanger. The furnace installation must conform with local building codes and ordinances or, in their absence, with the National Fuel Gas Code ANSI Z223.1 or CAN/CGA-B149.1, latest edition, and the National Electrical Code ANSI/NFPA-7 or CSA C22.1, latest edition. It is the personal responsibility and obligation of the purchaser to contact a qualified installer to assure that installation is adequate and is in conformance with governing codes and ordinances.

3. DUCT WORK

The unit is designed for use with or without duct work. See Warning on Page 6. Flanges are provided for attaching the supply and return ducts. These instructions explain the recommended method to install the air cooled self-contained electric air conditioning and gas heating unit and the electrical wiring connections and gas piping to the unit. The refrigerant system is completely assembled and charged. All internal wiring is complete.

These instructions and any instructions packaged with any separate equipment required to make up the entire heating/cooling system should be carefully read before beginning the installation. Note particularly “Starting Procedure” and any tags and/or labels attached to the equipment.

All duct work, supply and return, must be properly sized for the design air flow requirement of the equipment. Air Conditioning Contractors of America (ACCA) is an excellent guide to proper sizing.

Refer to Table 9 for maximum static pressure available for duct design.

**TABLE 1
SPECIFICATIONS**

| Model | SPECIFICATIONS | | | | | | | | | |
|----------------------------------|----------------|--------------|-------------|--------------|--------------|-------------|--------------|-------------|-------------|---------|
| | WG421DA | WG421DB | WG421DC | WG481DA | WG481DB | WG481DC | WG601DA | WG601DB | WG601DC | |
| <i>Electrical Rating</i> 60HZ | 230/208-60-1 | 230/208-60-3 | 460-60-3 | 230/208-60-1 | 230/208-60-3 | 460-60-3 | 230/208-60-1 | 230/20-60-3 | 460-60-3 | WG601DC |
| Operating Voltage Range | 197 - 253 | 187 - 253 | 414 - 506 | 197 - 253 | 187 - 253 | 414 - 506 | 197 - 253 | 187 - 253 | 414 - 506 | WG601DB |
| Minimum Circuit Ampacity | 30 | 23 | 11 | 34 | 23 | 12 | 44 | 31 | 15 | WG601DC |
| * Field Wire Size / | 8 | 8 | 14 | 8 | 8 | 14 | 8 | 8 | 12 | WG601DB |
| Ground Wire Size | 10 | 10 | 14 | 10 | 10 | 14 | 10 | 10 | 12 | WG601DC |
| ** Delay Fuse Max | 45 | 35 | 15 | 50 | 35 | 15 | 60 | 45 | 20 | WG601DB |
| <i>Compressor</i> | | | | | | | | | | |
| Compressor Type | Recp. | Recp. | Recp. | Scroll | Scroll | Scroll | Scroll | Scroll | Scroll | WG601DB |
| Volts | 230/208 | 230/208 | 230/208 | 460 | 230/208 | 230/208 | 230/208 | 230/208 | 460 | WG601DC |
| Rated Load Amps | 17.5/19 | 12/13 | 6 | 21/21.5 | 12.5/13 | 6.2 | 27/30 | 17/19.5 | 9 | WG601DB |
| Branch Circuit Selection Current | 19 | 13 | 6 | 22 | 13 | 6.4 | 30 | 19.5 | 9 | WG601DC |
| Lock Rotor Amps | 102/102 | 91/91 | 42 | 131/131 | 91/81 | 46 | 169/169 | 137/137 | 62 | WG601DB |
| <i>Fan Motor and Compressor</i> | | | | | | | | | | |
| Fan Motor HP/RPM/SPD | 1/3-850-2 | 1/3-850-2 | 1/3-850-1 | 1/3-850-2 | 1/3-850-2 | 1/3-850-1 | 1/3-850-2 | 1/3-850-2 | 1/3-850-1 | WG601DB |
| Fan Motor Amps | 2.5 | 2.5 | 1.3 | 2.5 | 2.5 | 1.3 | 2.5 | 2.5 | 1.3 | WG601DC |
| Fan DIA/CFM | 24"-2700 | 24"-2700 | 24"-2700 | 24"-2700 | 24"-2700 | 24"-2700 | 24"-2700 | 24"-2700 | 24"-2700 | WG601DB |
| <i>Motor and Evaporator</i> | | | | | | | | | | |
| Blower Motor HP/RPM/SPD | 1/2-1050-3 | 1/2-1050-3 | 1/2-1050-3 | 1/2-1050-3 | 1/2-1050-3 | 1/2-1050-3 | 1/2-1050-3 | 1/2-1050-3 | 1/2-1050-3 | WG601DB |
| Blower Motor Amps | 2.9 | 2.9 | 1.5 | 2.9 | 2.9 | 1.5 | 2.9 | 2.9 | 1.5 | WG601DC |
| CFM Cooling & E.S.P. | 1300 - .35 | 1300 - .35 | 1300 - .35 | 1550 - .38 | 1550 - .38 | 1550 - .38 | 1650 - .30 | 1650 - .30 | 1650 - .30 | WG601DB |
| Filter Sizes (Inches) | 20 x 30 x 2 | 20 x 30 x 2 | 20 x 30 x 2 | 20 x 30 x 2 | 20 x 30 x 2 | 20 x 30 x 2 | 20 x 30 x 2 | 20 x 30 x 2 | 20 x 30 x 2 | WG601DC |
| Charge (R-22 oz.) | 101 | 101 | 101 | 116 | 116 | 116 | 143 | 143 | 143 | WG601DB |

* 75 degree C Copper wire size
 ** Maximum time delay fuse or HACR Type circuit breaker

WARNING

In all cases, there must be a metal duct connection made to the supply air flange, and a one inch clearance to combustibles must be maintained to this duct connection.

For free blow applications, a metal sleeve must be used in the wall opening itself, again maintaining a one inch clearance to combustibles.

Failure to use the sheet metal can cause fire resulting in property damage, injury, or death.

See Figure 5 and clearance information in Section 9 and Table 2 for additional information.

Design the duct work according to methods given by the Air Conditioning Contractors of America (ACCA). When duct runs through unheated spaces, it should be insulated with a minimum of one inch of insulation. Use insulation with a vapor barrier on the outside of the insulation. Flexible joints should be used to connect the duct work to the equipment in order to keep the noise transmission to a minimum.

A one inch clearance to combustible material for the first three feet of duct attached to the outlet air frame is required. See Wall Mounting Instructions and Figures 4 and 5 for further details.

Ducts through the walls must be insulated and all joints taped or sealed to prevent air or moisture entering the wall cavity.

Some installations may not require any return air duct. A metallic return air grille is required with installations not requiring a return air duct. The spacing between louvers on the grille shall not be larger than 5/8 inch.

Any grille that meets with the 5/8 inch louver criteria may be used. It is recommended that Bard Return Air Grille RG5 or Return Filter Grille RFG5 be installed when no return duct is used. Contact distributor or factory for ordering information. If using a return air filter grille, filters must be of sufficient size to allow a maximum velocity of 400 fpm.

NOTE: If no return air duct is used, applicable installation codes may limit this cabinet to installation only in a single story structure.

4. HIGH ALTITUDE APPLICATIONS

Ratings of gas utilization equipment are based on sea level operation and need not be changed for operation at elevations up to 2,000 feet. For operation at elevations above 2,000 feet and in the absence of specific recommendations from the local authority having jurisdiction, equipment ratings shall be reduced as specified in Section 18.

5. TRANSPORTATION DAMAGE

All units are packed securely in shipping container. All units should be carefully inspected upon arrival for damage. In the event of damage, the consignee should:

1. Note on delivery receipt of any damage to container.
2. Notify carrier promptly, and request an inspection.
3. In case of concealed damage, the carrier must be notified as soon as possible within 15 days after delivery.
4. Claims for any damage, apparent or concealed, should be filed with the carrier, using the following supporting documents:
 - A. Original Bill of Lading, certified copy, or indemnity bond.
 - B. Original paid freight bill of indemnity in lieu thereof.
 - C. Original invoice or certified copy thereof showing trade and other discounts or deductions.
 - D. Copy of the inspection report issued by carrier's representative at the time damage is reported to carrier.

6. INSTALLATION

Size of unit for proposed installation should be based on heat loss/heat gain calculations made according to methods of Air Conditioning Contractors of America (ACCA). The air duct should be installed in accordance with the Standards of the National Fire Protection Association for the Installation of Air Conditioning and Ventilating Systems of Other Than Residence Type, NFPA No. 90A, and Residence Type Warm Air Heating and Air Conditioning Systems, NFPA No. 90B. Where local regulations are at a variance with instructions, installer should adhere to local codes.

7. WALL MOUNTING INFORMATION

1. Two holes for the supply and return air openings must be cut through the wall as detailed in Figure 4.
2. On wood-frame walls, the wall construction must be strong and rigid enough to carry the weight of the unit without transmitting any unit vibration.
3. Concrete block walls must be thoroughly inspected to insure that they are capable of carrying the weight of the installed unit.

8. MOUNTING THE UNIT

1. These units are secured by wall mounting brackets which secure the unit to the outside wall surface at both sides. A bottom mounting bracket is provided for ease of installation but is not required.

CAUTION

If the bottom bracket is used, be certain the bracket is secured to the outside wall surface in a way sufficient to support the entire weight of the unit during installation until side mounting brackets are secured.

2. The unit itself is suitable for 0 inch clearance, but the supply air duct flange and the first 3 feet of supply air duct require a minimum of one inch clearance to combustible material. If a combustible wall, use a minimum of 12" x 32" dimensions for sizing. See Figures 6 and 7 for details.

WARNING

Failure to provide the one inch clearance between the supply duct and a combustible surface for the first three feet of duct can result in fire causing damage, injury or death.

3. Locate and mark lag bolt locations and bottom mounting bracket location.
4. Mount bottom mounting bracket.
5. Hook top rain flashing under back bend of top. Top rain flashing is shipped secured to the right side of the back.
6. Position unit in opening and secure with 5/16 lag bolts; use 7/8 inch diameter flat washers on the lag bolts.
7. Secure rain flashing to wall and caulk across entire length of top. See Figure 4.
8. On side by side installations, maintain a minimum of 20 inches clearance on right side to allow access to control panel and burner compartment, and to allow proper airflow to the outdoor coil. Additional clearance may be required to meet local or national codes.

**FIGURE 2
VENT TERMINAL AND COMBUSTION AIR INTAKE**

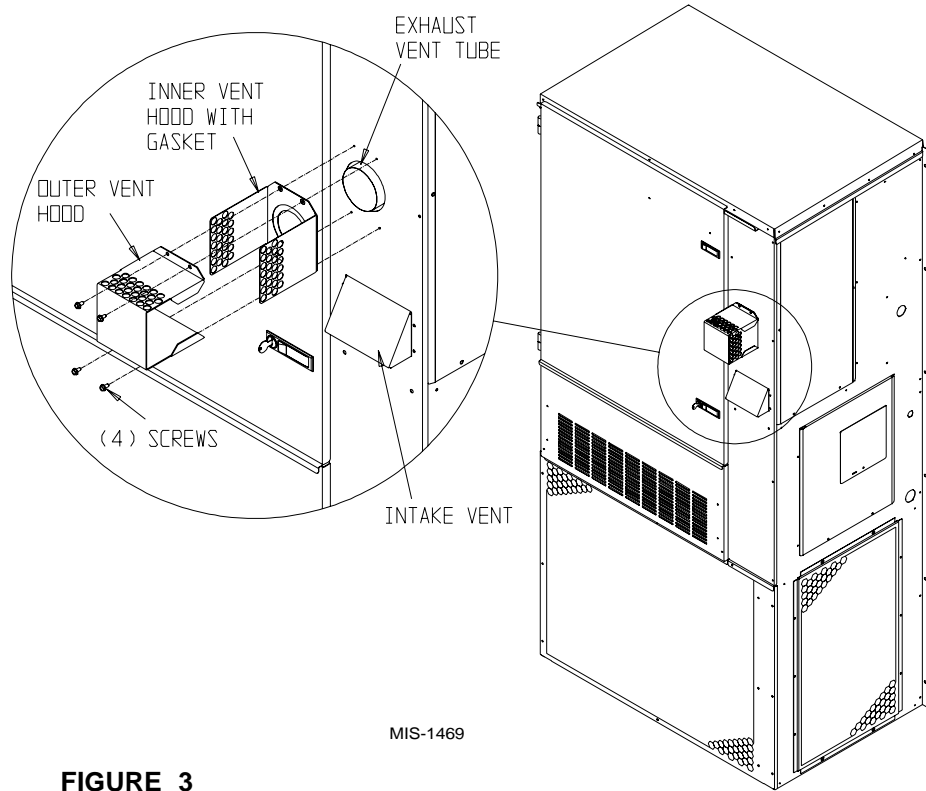

**FIGURE 3
INTERNAL FILTER ACCESS THROUGH UPPER SERVICE DOOR**

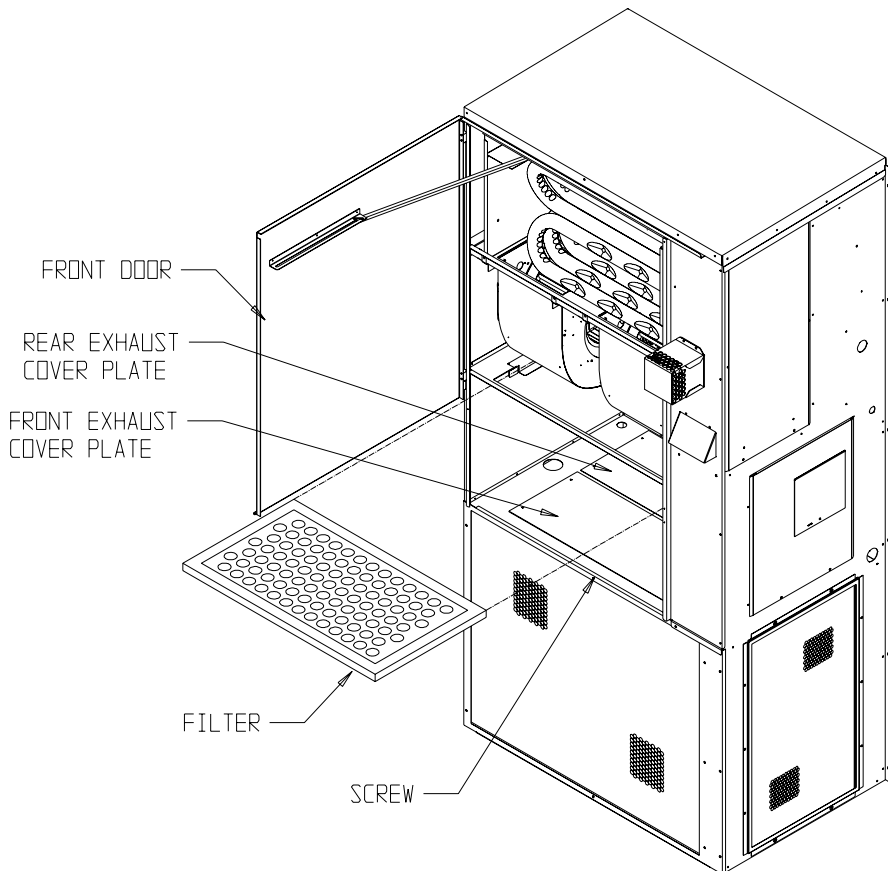

**FIGURE 5
COMBUSTIBLE CLEARANCE**

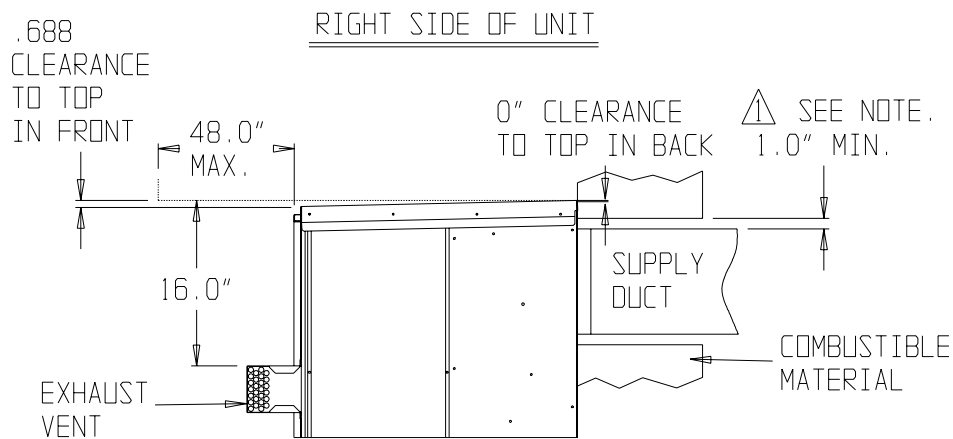

△ SIDE SECTION VIEW OF SUPPLY AIR DUCT
FOR WALL MOUNTED UNIT SHOWING 1.0"
CLEARANCE TO ALL COMBUSTIBLE SURFACES.

MIS-1473

WARNING

A **minimum** of one (1) inch clearance must be maintained between the supply air duct and combustible materials. This is required for the first three (3) feet of ducting.

It is important to insure that the one (1) inch minimum spacing is maintained at all points.

Failure to do this could result in overheating the combustible material and may result in a fire causing damage, injury or death.

**FIGURE 6
WALL MOUNTING INSTRUCTIONS**

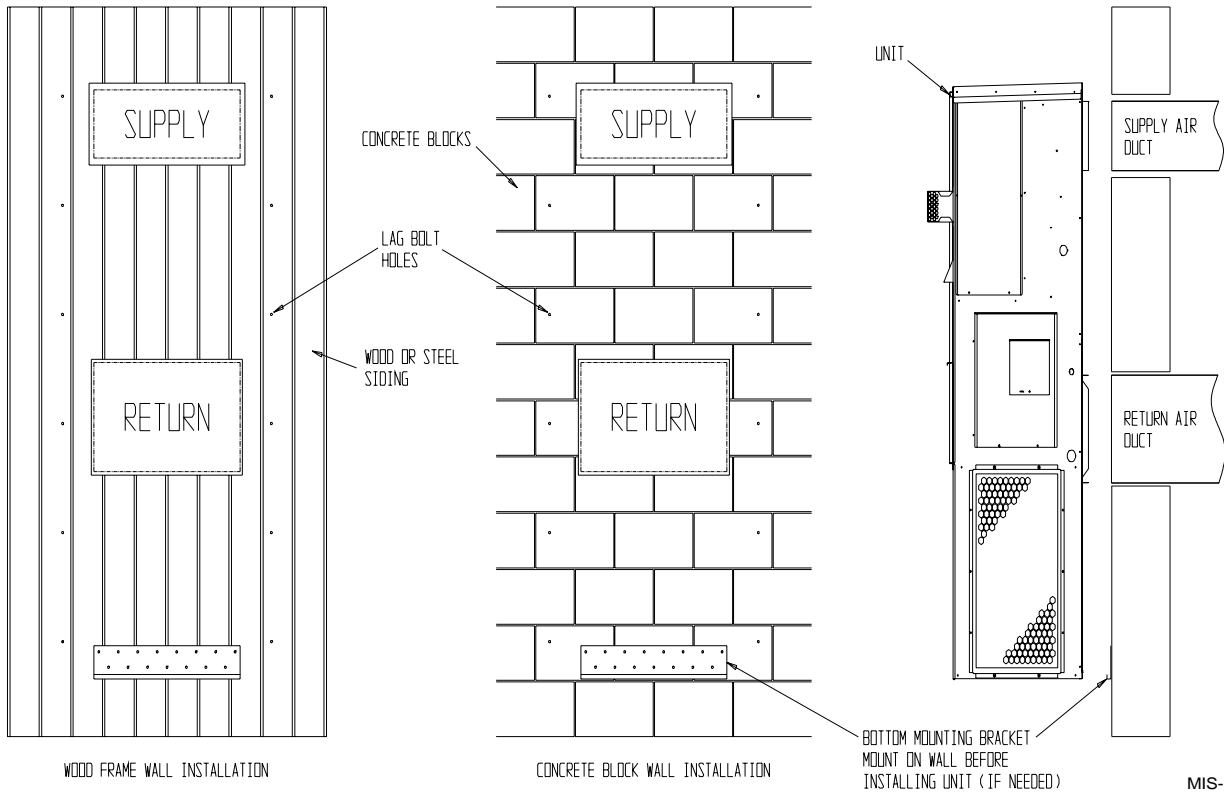

**FIGURE 7
WALL MOUNTING INSTRUCTIONS**

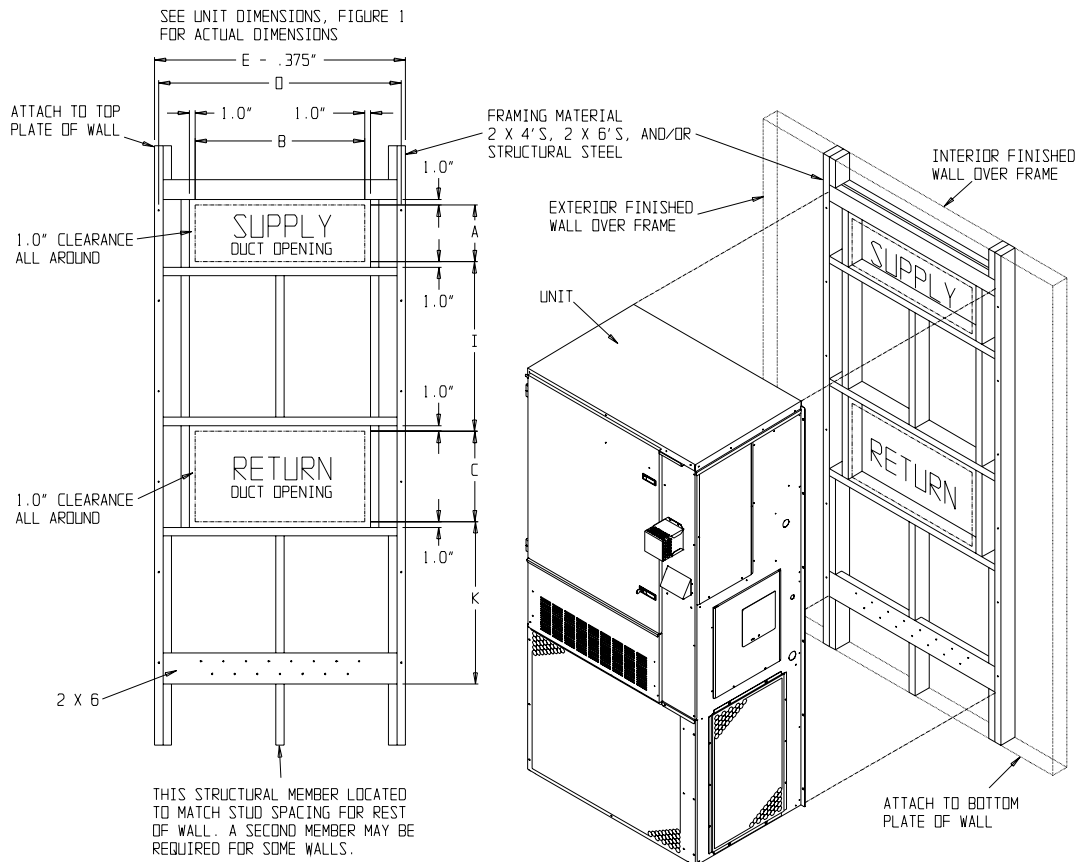

**FIGURE 8
COMMON WALL MOUNTING INSTALLATIONS**

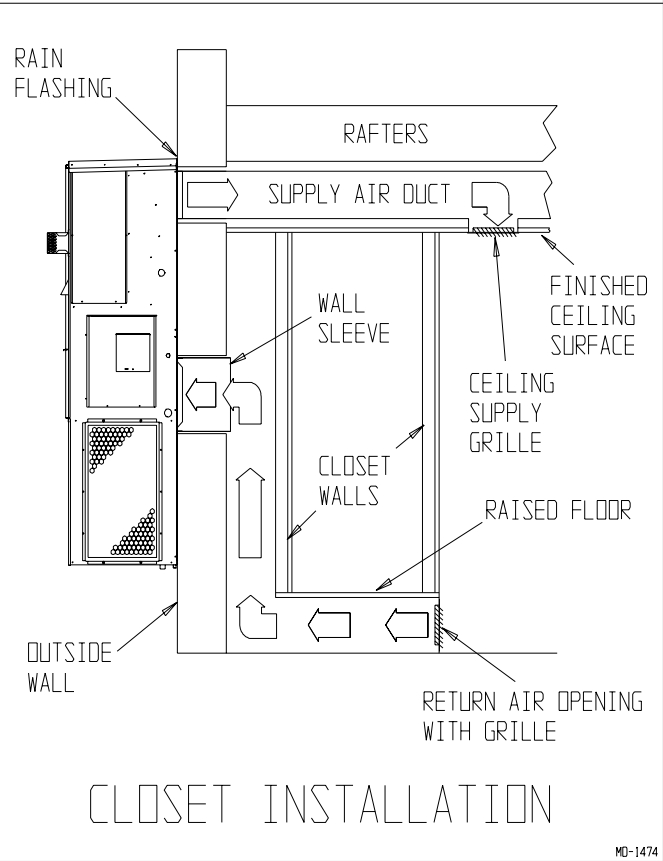
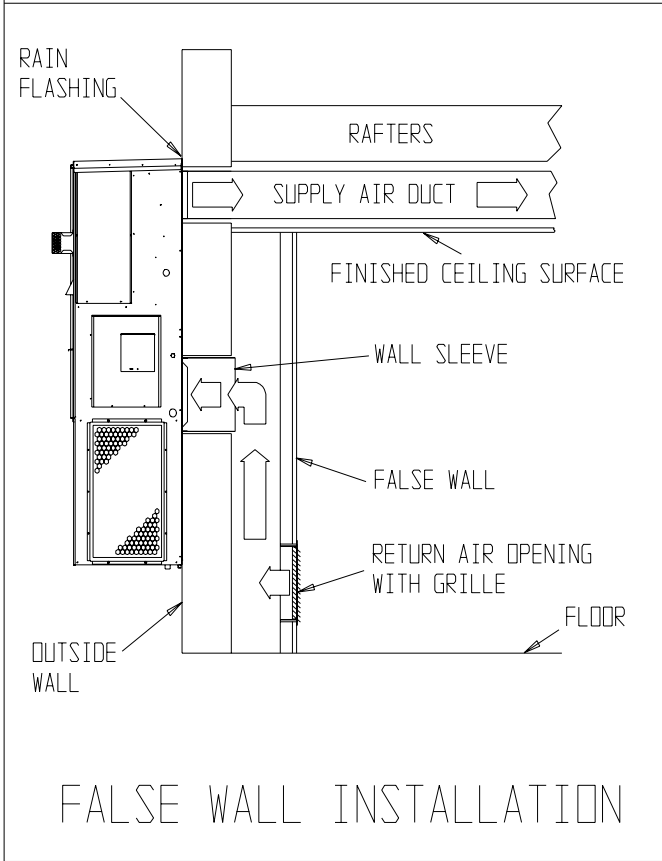
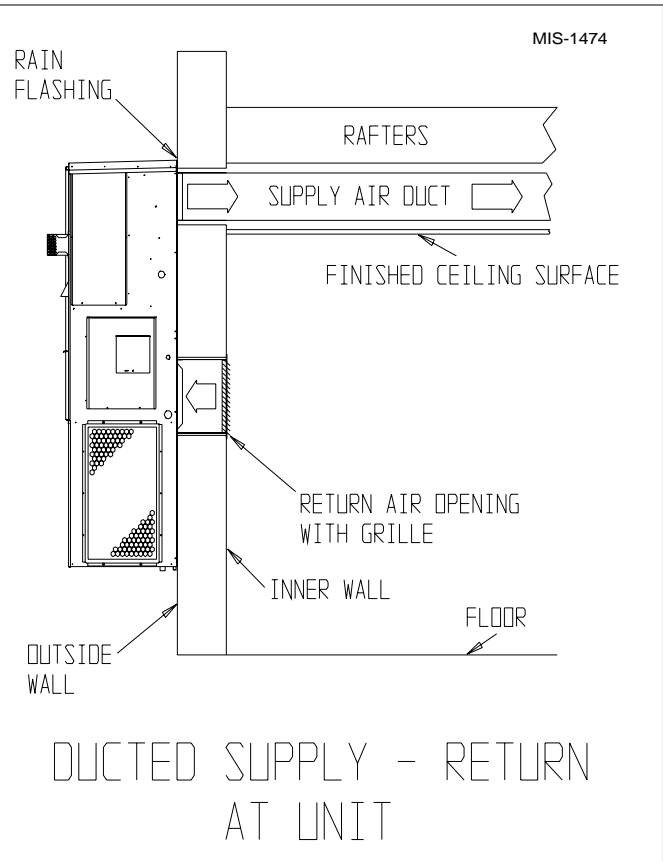
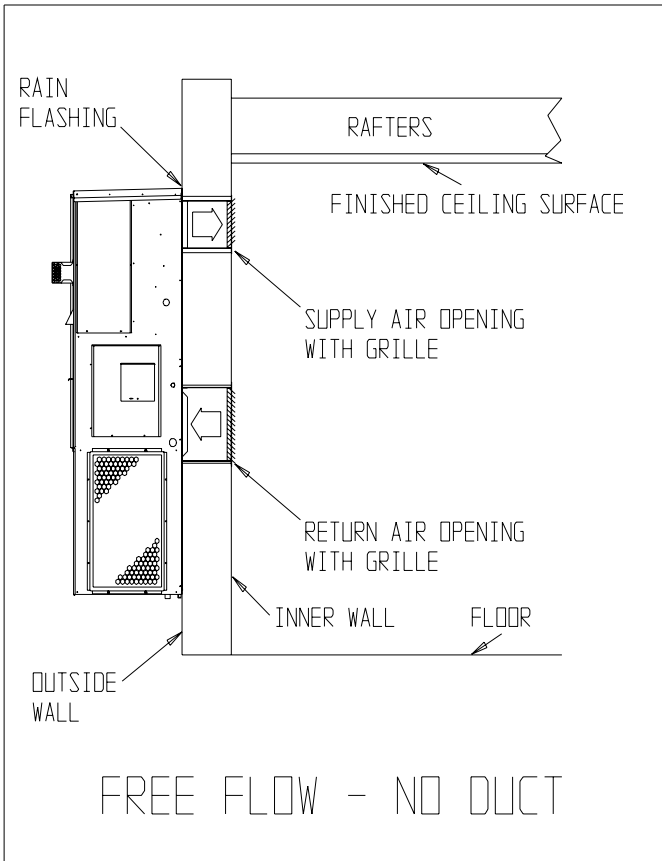

MD-1474

9. CLEARANCES

Minimum clearances, as specified in Table 2, must be maintained from adjacent structures to provide adequate fire protection, adequate combustion air, and room for service personnel.

While minimum clearances are acceptable for safety reasons, they may not allow adequate air circulation around the unit for proper operation in the cooling mode. Whenever possible, it is desirable to allow additional clearance, especially around the condenser inlet and discharge openings. DO NOT install the unit in a location that will permit discharged air from the condenser to recirculate to the condenser inlet.

**TABLE 2
MINIMUM INSTALLATION CLEARANCES**

| | |
|---|---------------------|
| Outlet Duct (from combustible materials) | 1 inch first 3 feet |
| Vent Terminal (from combustible materials) | 16 inches |
| Condenser outlet | 20 inches |
| Top | See Figure 5 |
| Burner Service | 20 inches |
| Combustible Base (Wood or Class A, B or C roof covering material) | 0 inches |

WARNING

Clearances from combustible materials must be maintained as specified. Failure to maintain clearances could cause fire resulting in property damage, injury, or death.

10. VENT TERMINAL AND COMBUSTION AIR INLET HOOD

The vent terminal is shipped in the burner compartment. Remove the two shipping screws and separate the two-piece assembly. Install the vent terminal by using the four screws provided. Make sure gasket is in place. See Figure 2. The combustion air intake hood is factory installed.

11. OPTIONAL VERTICAL VENTING

With the optional vertical venting kit this unit may be vented vertically through a roof or overhang. The kit includes a stainless steel transition drain tee, silicone sealant, and drain tubing.

CAUTION

Vent terminal must be installed as shown in Figure 2 for proper operation of the heating system.

12. VENT RESIZING INSTRUCTIONS

When an existing furnace is removed from a venting system servicing other appliances, the venting system is likely to be too large to properly vent the remaining attached appliances.

The following steps shall be followed with each of the appliances remaining connected to the common venting system, placed in operation one at a time while the other appliances remaining connected to the common venting system are not in operation.

1. Seal any unused openings in the venting system;
2. Inspect the venting system for proper size and horizontal pitch, as required in the National Fuel Gas code, ANSI Z223.1 or the CAN/CGA B149 Installation Codes and these instructions. Determine that there is no blockage or restriction, leakage, corrosion and other deficiencies which could cause an unsafe condition;
3. In so far as is practical, close all building doors and windows and all doors between the space in which the appliance(s) connected to the venting system are located and other spaces of the building. Turn on clothes dryers and any appliances not connected to the venting system. Turn on any exhaust fans, such as range hoods and bathroom exhausts, so they will operate at maximum speed. Do not operate a summer exhaust fan. Close fireplace dampers;
4. Follow the lighting instructions. Place the appliance being inspected in operation. Adjust thermostat so appliance shall operate continuously;
5. Test for draft hood equipped appliance spillage at the draft hood relief opening after 5 minutes of main burner operation. Use the flame of a match or candle;
6. After it has been determined that each appliance connected to the venting system properly vents when tested as outlined above, return doors, windows, exhaust fans, fireplace dampers and any other gas-burning appliances to their previous conditions of use;
7. If improper venting is observed during any of the above tests, the venting system must be corrected.

13. FRESH AIR INTAKE

All units are built with fresh air inlet slots punched in the service panel.

If the unit is equipped with a fresh air damper assembly, the assembly is shipped already attached to the unit. The damper blade is locked in the closed position. To allow the damper to operate, the maximum and minimum blade position stops must be installed. See Figure 9.

All capacity, efficiency and cost of operation information as required for Department of Energy “Energyguide” Fact Sheets is based upon the fresh air blank-off plate in place and is recommended for maximum energy efficiency.

The blank-off plate is available upon request from the factory and is installed in place of the fresh air damper shipped with each unit.

One of several other ventilation options may be installed. Refer to model number and/or supplemental installation instructions.

14. CONDENSATE DRAIN

A plastic drain hose extends from the drain pan at the top of the unit down to the unit base. There are openings in the unit base for the drain hose to pass through. In the event the drain hose is connected to a drain system of some type, it must be an open or vented type system to assure proper drainage.

**FIGURE 9
FRESH AIR DAMPER**

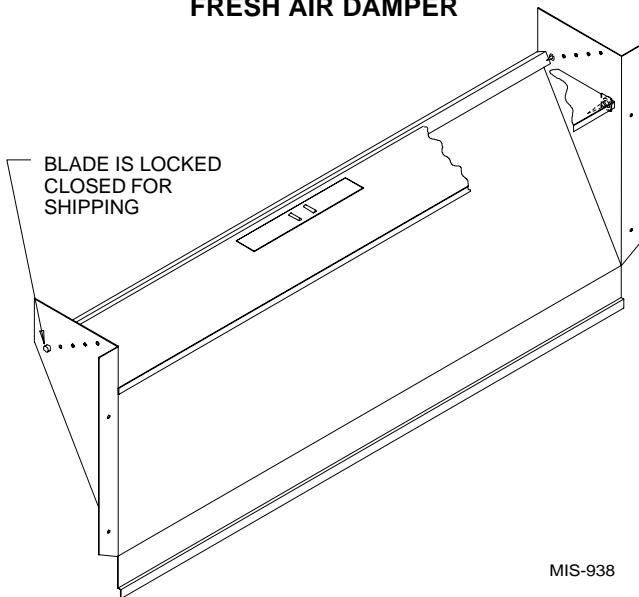

15. WIRING – MAIN POWER

WARNING

For your personal safety, turn off electric power at service entrance panel before making any electrical connections. Failure to do so could result in electric shock or fire.

Refer to unit rating plate for wire sizing information and maximum fuse or “HACR” type circuit breaker size. Each outdoor unit is marked with a “Minimum Circuit Ampacity”. This means that the field wiring used must be sized to carry that amount of current. All models are suitable only for connection with copper wire. Each unit and/or wiring diagram will be marked - “Use Copper Conductors Only”. These instructions **must be** adhered to. Refer to the National Electrical Code (NEC) for complete current carrying capacity data on the various insulation grades of wiring material. All wiring must conform to NEC and all local codes.

The electrical data lists fuse and wire sizes (75° C copper) for all models.

The unit rating plate lists a “Maximum Time Delay Relay Fuse” or “HACR” type circuit breaker that is to be used with the equipment. The correct size must be used for proper circuit protection and also to assure that there will be no nuisance tripping due to the momentary high starting current of the compressor motor.

The disconnect access door on this unit may be locked to prevent unauthorized access to the disconnect. To convert for the locking capability bend the tab located in the bottom left hand corner of the disconnect opening under the disconnect access panel straight out. This tab will now line up with the slot in the door. When shut a padlock may be placed through the hole in the tab preventing entry.

See “Start Up” section for important information on three phase scroll compressor start ups.

WARNING

Failure to provide an electrical power supply shut-off means could result in electric shock or fire.

ELECTRICAL GROUNDING

When installed, the furnace must be electrically grounded in accordance with local codes or in the absence of local codes, with the National Electrical Code, ANSI/NFPA 70, or Canadian Electrical Code, CSA22.1, latest edition. Use a copper wire from green ground wire on the furnace to a grounded connection in the service panel or a properly driven and electrically grounded ground rod. See Table 1 for proper ground wire size.

| |
|--|
|  WARNING |
| Failure to provide a proper electrical ground could result in electric shock or fire. |

FIELD INSTALLED EQUIPMENT

Wiring to be done in the field between the furnace and devices not attached to the furnace, or between separate devices which are field installed and located, shall conform with the temperature limitation for Type T wire {63 degrees F rise (36 degrees C)} when installed in accordance with the manufacturer's instructions.

INSTALLATION OF FLEXIBLE CONDUIT THROUGH RETURN AIR OPENING

NOTE: To allow proper clearance between the control panel and any vent options, 90° conduit fittings must be used on the back of the control panel.

INSTALLING CONDUIT

1. Remove conduit access panel if required to gain access to area behind control panel.
2. Remove low voltage and high voltage knockouts located in rear of control panel.
3. Run low voltage conduit through 7/8" bushing located in conduit entrance plate and secure to low voltage opening in rear of control panel.
4. Run high voltage conduit through 1-3/4" bushing located in conduit entrance plate and secure to high voltage opening in rear of control panel.
5. Replace conduit access panel if required to complete installation.
6. Seal around conduit in conduit entrance plate.

**FIGURE 10
INSTALLATION OF FLEXIBLE CONDUIT**

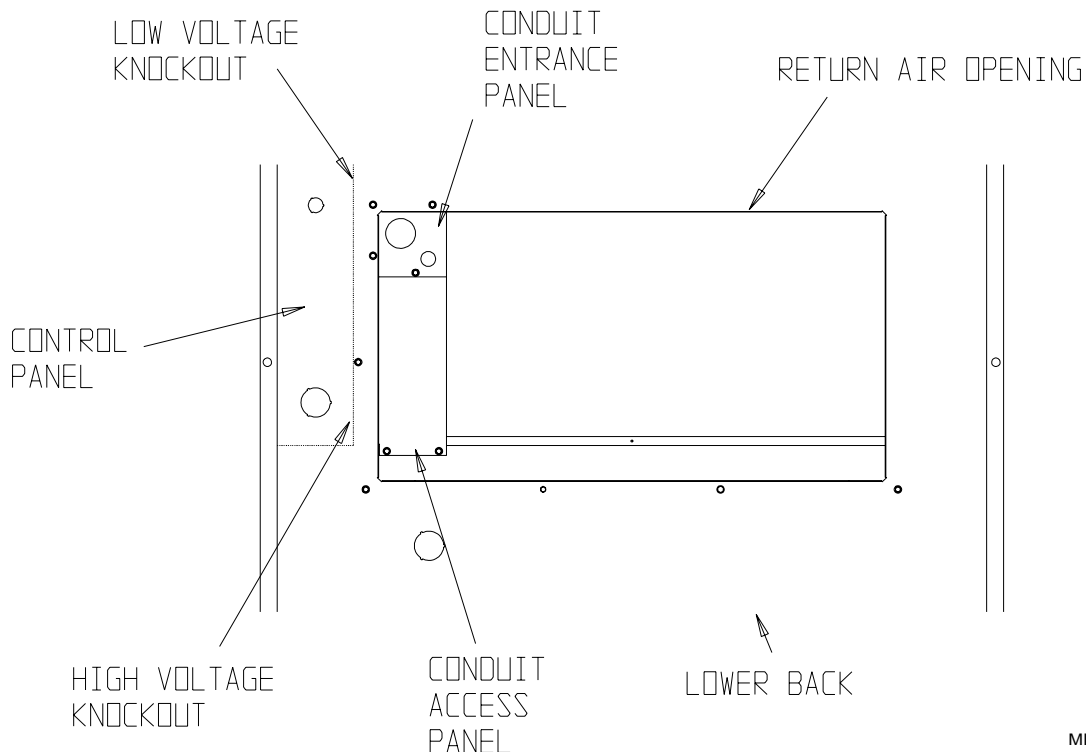

MIS-1553

16. WIRING – LOW VOLTAGE WIRING

230/208 VOLT UNITS

All models are equipped with dual primary voltage transformers. All equipment leaves the factory wired on 240V tap. For 208V operation, reconnect from 240V to 208V tap. The acceptable operating voltage range for the 240V and 208V taps are:

| TAP | RANGE |
|-----|-------------|
| 240 | 253 - - 216 |
| 208 | 220 - - 187 |

NOTE: The voltage should be measured at the field power connection point in the unit and while the unit is operating at full load (maximum amperage operating condition).

460 VOLT UNITS

All models are equipped with single primary voltage transformers and no rewiring is required.

17. THERMOSTATS

**TABLE 3
THERMOSTAT WIRE SIZE**

| Transformer VA | FLA | Wire Gauge | Maximum Distance In Feet |
|----------------|-----|------------|--------------------------|
| 55 | 2.3 | 20 gauge | 45 |
| | | 18 gauge | 60 |
| | | 16 gauge | 100 |
| | | 14 gauge | 160 |
| | | 12 gauge | 250 |

**TABLE 4
WALL THERMOSTAT AND SUBBASE COMBINATIONS**

| Thermostat | Subbase | Predominate Features |
|------------------------|-----------------------|---|
| 8403-002 T87F3111 | 8404-003 Q539A1220 | 1 stage heat, 1 stage cool; Mercury System: heat-off-cool Fan: on-auto |
| 8403-041 T8034C1499 | --- | 1 stage heat, 1 stage cool; Mercury System: heat-off-cool Fan: on-auto |
| 8403-035 1F95-80 | --- | 2 stage heat, 2 stage cool Programmable Electronic |
| 8403-043 CM200 | --- | 1 stage heat, 1 stage cool System: heat-off-cool Fan: on-auto Snap Action |

**FIGURE 11
LOW VOLTAGE WIRING**

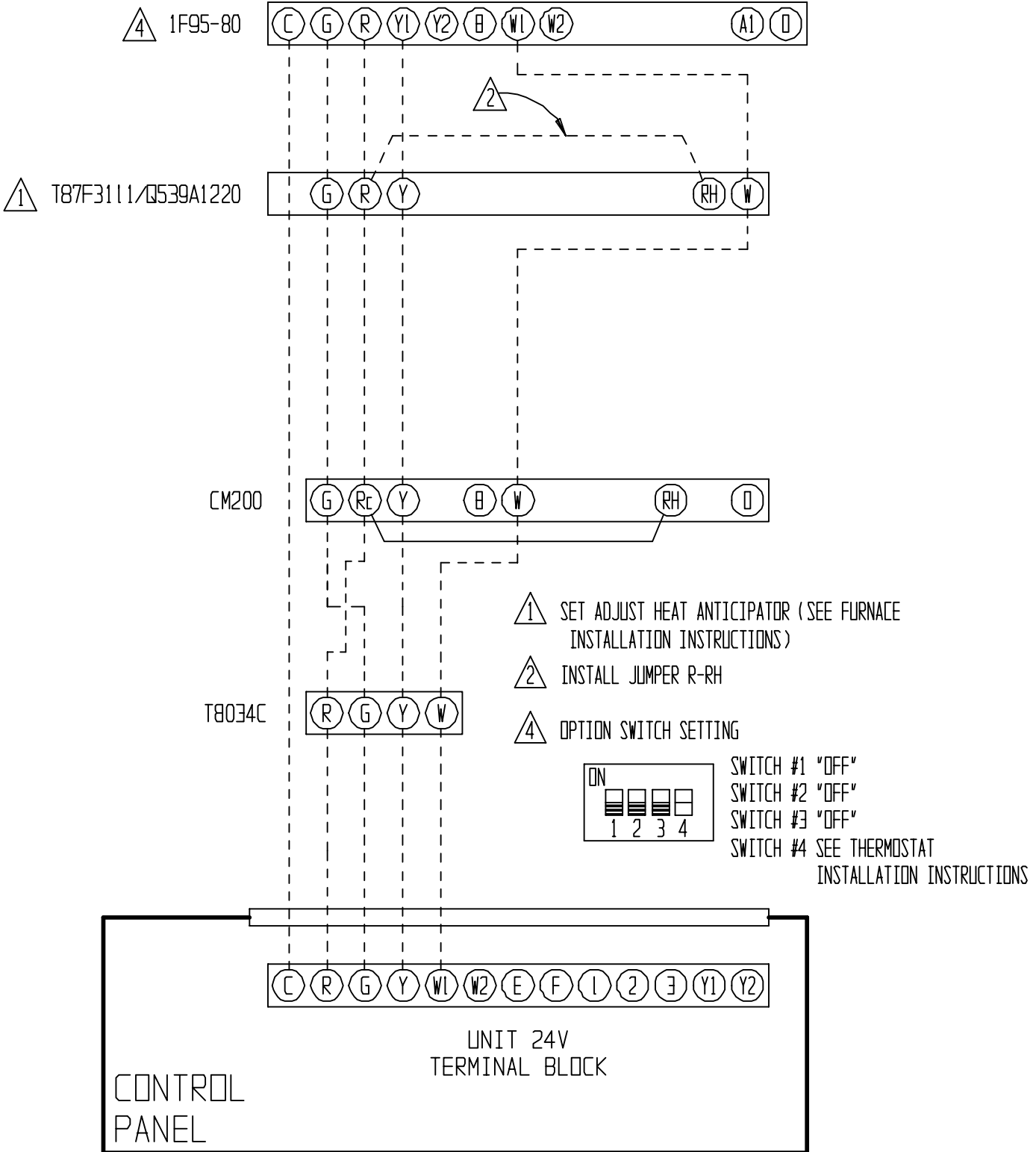

**FIGURE 12
GAS PIPE CONNECTION**

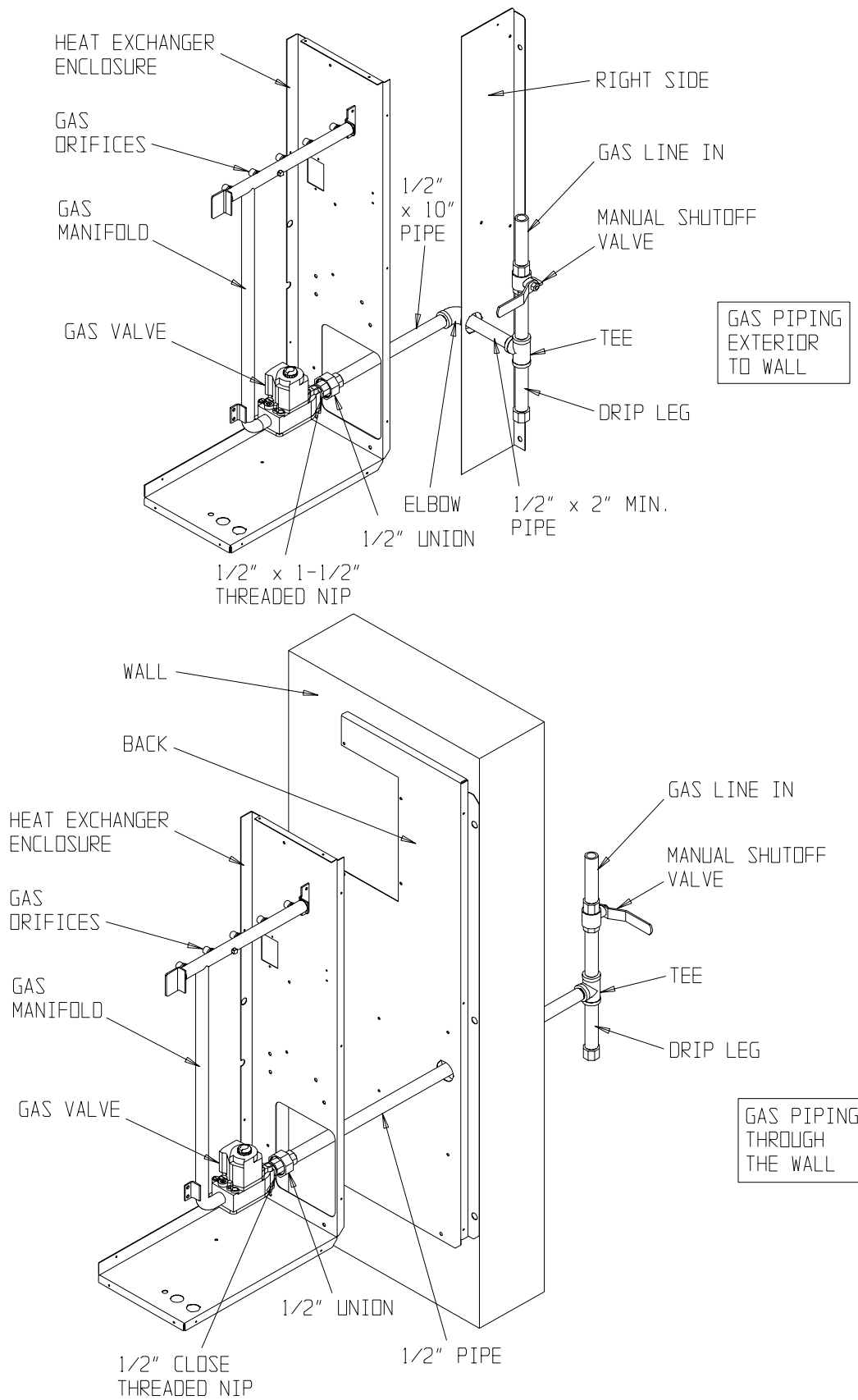

MIS-1478

18. GAS SUPPLY AND PIPING

GENERAL RECOMMENDATIONS

1. Be sure the gas line complies with the local codes and ordinances, or in their absence with the National Fuel Gas Code, ANSI Z223.1, or Natural Gas Installation Code, CAN/CGA B149.1, or Propane Installation Code B149.2, latest edition.
2. A sediment trap or drip leg must be installed in the supply line to the furnace.
3. A ground joint union shall be installed in the gas line adjacent to and upstream from the gas valve and downstream from the manual shut-off valve.
4. An 1/8" NPT plugged tapping accessible for test gauge connection shall be installed immediately upstream of the gas supply connection to the furnace for the purpose of determining the supply gas pressure. This can be omitted if local codes permit use of plugged tapping in gas valve inlet.
5. Install listed manual shut-off valve in the supply gas line external to and immediately upstream of the furnace. See Figure 12.
6. Use steel or wrought iron pipe and fittings.
7. *DO NOT* thread pipe too far. Valve distortion or malfunction may result from excess pipe within the control. Use pipe joint compound resistant to the action of liquefied petroleum gases on male threads only. *DO NOT* use Teflon tape. See Table 5 and Figure 13.

**TABLE 5
LENGTH OF STANDARD
PIPE THREADS (INCHES)**

| Pipe Size | Effective Length of Thread | Overall Length of Thread |
|-----------|----------------------------|--------------------------|
| 3/8 | 1/2 | 9/16 |
| 3/4 | 1/2 - - 9/16 | 13/16 |
| 1 | 9/16 | 1 |

**FIGURE 13
PROPER PIPING PRACTICE**

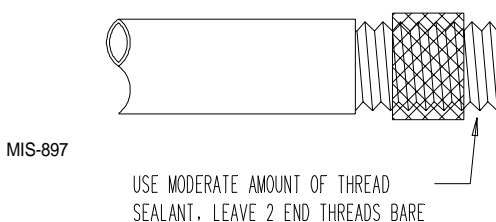

8. Refer to Table 6 for Gas Pipe Sizes for natural gas. If more than one appliance is supplied from a single line size, capacity must equal or exceed the combined input to all appliances, and the branch lines feeding the individual appliances properly sized for each input.

**TABLE 6
GAS PIPE SIZES - NATURAL GAS**

| Length of Pipe - Feet | Pipe Capacity - BTU per Hour Input Pipe Size | | | |
|-----------------------|--|---------|---------|-----------|
| | 1/2" | 3/4" | 1" | 1-1/4" |
| 10 | 132,000 | 278,000 | 520,000 | 1,050,000 |
| 20 | 92,000 | 190,000 | 350,000 | 730,000 |
| 30 | 73,000 | 152,000 | 285,000 | 590,000 |
| 40 | 63,000 | 130,000 | 245,000 | 500,000 |
| 50 | 56,000 | 115,000 | 215,000 | 440,000 |
| 60 | 50,000 | 105,000 | 195,000 | 400,000 |
| 70 | 46,000 | 96,000 | 180,000 | 370,000 |
| 80 | 43,000 | 90,000 | 170,000 | 350,000 |
| 100 | 38,000 | 79,000 | 150,000 | 305,000 |

CHECKING THE GAS PIPING

Before turning gas under pressure into piping, all openings from which gas can escape should be closed. Immediately after turning on gas, the system should be checked for leaks. This can be done by watching the 1/2 cubic foot test dial and allowing 4 minutes to show any movement, and by soaping each pipe connection and watching for bubbles. If a leak is found, make the necessary repairs immediately and repeat the above test. The furnace must be isolated from the gas supply piping system by closing the manual shut-off valve on the combination gas control valve during pressure testing of the gas supply piping system at pressures up to 1/2 PSIG. The furnace and its individual shut-off valve must be disconnected from supply piping and supply piping capped during any pressure testing of supply piping system at test pressures in excess of 1/2 PSIG.

Defective pipes or fittings should be replaced and not repaired. Never use a flame or fire in any form to locate gas leaks; use a soap solution.

After the piping and meter have been checked completely, purge the system of air. *DO NOT* bleed air inside the furnace. ***Be sure to check and relight all the gas pilots on other appliances that may have been extinguished because of interrupted gas supply.***

19. MANIFOLD PRESSURE ADJUSTMENT

You will need a 0 to 15 inch water manometer with 0.1 inch resolution and a 1/8" NPT manual shut-off valve to measure actual manifold pressure.

WARNING

Correct manifold pressure is necessary for proper ignition and burner operation. Failure to accurately adjust pressure could cause heat exchanger failure.

1. Turn off gas at equipment shut-off valve in gas supply line just ahead of furnace.
 2. Remove plug from outlet pressure tap in gas control or gas manifold.
 3. Install 1/8" NPT manual shut-off valve in hole vacated by plug. Make sure shut-off valve is in off position.
 4. Attach manometer to 1/8" NPT manual shut-off valve just installed.
 5. Slowly open equipment shut-off valve in gas supply line just ahead of furnace. Start furnace following "Operating Instructions" on front door.
 6. Slowly open 1/8" NPT manual shut-off valve leading to manometer.
 7. Read manifold pressure on manometer.
 8. Adjust manifold pressure by turning gas control regulator adjusting screw clockwise to increase pressure or turning counterclockwise to decrease pressure. Manifold pressure must be within allowable range below:
 - Natural gas manifold pressure must be between 3.2 and 3.8 inches W.C. Rated pressure is 3.5 inches.
 - Propane gas (LP) manifold pressure must be between 9.7 and 10.3 inches W.C. Rated pressure is 10 inches.
- NOTE: For natural gas, if gas flow rate can't be properly set within these pressure ranges then you must change main burner orifices to obtain proper gas flow rate.*
9. Shut off furnace. Turn off gas at equipment shut-off valve in gas supply line just ahead of furnace. Install outlet pressure tap plug in gas control. Turn on gas.
 10. Check regulator adjustment cover screw and gas control plug for gas leaks. Use a commercial soap solution made for leak detection.

20. CHECKING GAS INPUT RATE

It is the installer's responsibility to see that the BTU input rate of the furnace is properly adjusted. Underfiring could cause inadequate heat, excessive condensation or ignition problems. Overfiring could cause sooting, flame impingement or overheating of heat exchanger.

WARNING

Failure to adjust furnace to the proper firing rate could cause heat exchanger failure.

Depending on your local gas heating value and elevation, you may need to adjust manifold pressure or change orifices to get proper gas input rate. Check with your local gas supplier to determine heating value (BTU/cu. ft.) of natural gas in your area.

NOTE: If furnace is being installed at an altitude of more than 2000 feet above sea level, you must derate the furnace. See Section 18 "Standard Orifice Sizing and High Altitude Derate".

NATURAL GAS INPUT RATE

Natural gas heating value (BTU/cu. ft.) can vary significantly. Before starting natural gas input check, obtain gas heating value at your location from local supplier. You will need a stopwatch to measure actual gas input.

1. Gas supply pressure must be between 5 and 7 inches W.C. for natural gas.
2. Turn off all other gas appliances. You may leave pilots on.
3. Start furnace following "Operating Instructions" on front door.
4. Let furnace warm up for 6 minutes.
5. Locate gas meter. Determine which dial has the least cubic feet of gas and how many cubic feet per revolution it represents. This is usually one-half, one or two cubic feet per revolution.

6. With stopwatch, measure time it takes to consume two cubic feet of gas.
- If dial is one-half cubic foot per revolution, measure time for four revolutions.
 - If dial is one cubic foot per revolution, measure time for two revolutions.
 - If dial is two cubic feet per revolution, measure time for one revolution.
7. Divide this time by two. This gives average time for one cubic foot of gas to flow through meter.
Example: If it took 58 seconds for two cubic feet to flow, it would take 29 seconds for one cubic foot to flow.

8. Calculate gas input using this formula:

$$\text{Gas input} = \frac{\text{Gas Heating Value (BTU/cu. ft.)} \times 3,600 \text{ sec/hr}}{\text{Time (Seconds for one cubic foot of gas)}} = \text{BTU/hour}$$

Example:

Assume it took 29 seconds for one cubic foot of gas to flow and heating value of 1,000 BTU/cu. ft.

$$\text{Gas input} = \frac{1,000 \times 3,600}{29} = 124,138 \text{ BTU}$$

If you left no other pilots on, this is the furnace gas input.

9. If you left water heater, dryer or range pilots on, allow for them in calculating correct furnace gas input. A quick way is to allow 1,000 BTU per hour for a water heater, 500 BTU per hour for dryer and 500 BTU per hour for each range burner pilot.

Example:

If you left gas water heater, dryer, two range burner pilots and one oven pilot on, allow:

| | |
|-----------------------|--------------------|
| Water heater pilot | 1,000 BTU per hour |
| Dryer pilot | 500 BTU per hour |
| 2 range burner pilots | 1,000 BTU per hour |
| 1 range oven pilot | 500 BTU per hour |
| | 3,000 BTU per hour |

Subtracting 3,000 BTU per hour from 124,138 BTU per hour measured above equals 121,138 BTU per hour. This would be the correct furnace gas input after allowing for pilots left on.

10. Manifold pressure may be adjusted within the range of 3.2 inches W.C. to 3.8 inches W.C. to get rated input \pm 2 percent. See Section 17, "Manifold Pressure Adjustment". If you cannot get rated input with manifold pressure within the allowable range, you must change orifices.

PROPANE (LP) GAS INPUT RATE



Propane (LP) gas installations do not have gas meters to double check input rate. Measure manifold pressure adjustment with an accurate manometer. Failure to accurately adjust pressure could cause heat exchanger failure, asphyxiation, fire or explosion, resulting in damage, injury or death.

1. Make sure you have proper main burner orifices.
2. Gas supply pressure must be between 11 and 13 inches W.C. for propane (LP) gas.
3. Start furnace following "Operating Instructions" on front door.
4. Let furnace warm up for 6 minutes.
5. Adjust manifold pressure to 10.0 W.C. \pm 0.3 inches W.C. See Section 19, "Manifold Pressure Adjustment".



Do not set Propane (LP) manifold pressure at 11.0 inches W.C. It could cause heat exchanger failure.

21. STANDARD ORIFICE SIZING AND HIGH ALTITUDE DERATE

This furnace is shipped with fixed gas orifices for use with Natural Gas and sized for 1000 BTU/cubic foot gas. Make sure actual gas input does not exceed rating plate input. You may need to change orifices to get correct gas input. Whether you do or not depends on input, and your gas heat value at standard conditions and elevation. Consult your local gas supplier for gas heat value and any special derating requirements. See Section 19 for more information.

At higher altitudes, the density of the air is reduced. Therefore, for proper combustion, the quantity of gas burned in the furnace must also be reduced. This is called derating. Furnaces must be derated when installed at altitudes greater than 2,000 feet above sea level.

At elevations above 2,000 feet the furnace must be derated. It is the installer's responsibility to see that the furnace input rate is adjusted properly. Derating must be achieved by reducing the size of the main burner orifices. Derating the furnace by adjusting the manifold pressure lower than the range specified in the Section 16, "Manifold Pressure Adjustment" is considered to be an improper procedure.

U. S. INSTALLATIONS ONLY

Ratings of gas utilization equipment are based on sea level operation and need not be changed for operation at elevations up to 2,000 feet. For operation at elevations above 2,000 feet, and in the absence of specific recommendations from the local authority having jurisdiction, equipment ratings shall be reduced at the rate of 4 percent per each 1,000 feet above sea level before selecting appropriately sized equipment. (Ref. ANSI Z223.1 - latest edition). See Table 7 for high altitude derate information, and for fuel gas BTU ratings from 800-1100 BTU per cubic foot.

**TABLE 7
HIGH ALTITUDE DERATE CHARTS
U.S. INSTALLATIONS ONLY**

| NATURAL GAS -- ORIFICE SIZE CHART FOR FACTORY STANDARD 25,000 BTU PER BURNER | | | | | | | | | |
|---|-----------------------|----------------------------|----------------------------|----------------------------|----------------------------|----------------------------|----------------------------|----------------------------|-----------------------------|
| Gas Heat * Value BTU/Cu. Ft. | Up to 2000 Feet | 2001 to 3000 Feet | 3001 to 4000 Feet | 4001 to 5000 Feet | 5001 to 6000 Feet | 6001 to 7000 Feet | 7001 to 8000 Feet | 8001 to 9000 Feet | 9001 to 10000 Feet |
| 800 - 849 | 2.70 | 2.60 | 2.50 | 2.50 | 2.45 | 2.40 | 2.35 | 2.30 | 2.30 |
| 880 - 899 | 2.60 | 2.50 | 2.45 | 2.40 | 2.40 | 2.30 | 2.30 | 2.25 | 2.20 |
| 900 - 949 | 2.50 | 2.40 | 2.35 | 2.35 | 2.30 | 2.25 | 2.20 | 2.15 | 2.10 |
| 950 - 999 | 2.45 | 2.35 | 2.30 | 2.30 | 2.25 | 2.20 | 2.15 | 2.10 | 2.05 |
| 1000 - 1049 | 2.40 | 2.30 | 2.30 | 2.20 | 2.20 | 2.15 | 2.10 | 2.05 | 2.00 |
| 1050-1100 | 2.30 | 2.25 | 2.20 | 2.15 | 2.15 | 2.10 | 2.05 | 2.00 | 1.95 |

* At standard conditions: 30.00 inches Mercury, 60F, saturated.

NOTE: **2.40** Standard factory installed orifice size. **2.30** is shipped with the unit for field installed optional 10% derate. All orifice sizes not shown with black background are available in U.S. Natural Gas High Altitude Kit, Bard Part No. GCK-US-N1. Orifice sizes shown with black background available separately.

| NATURAL GAS -- ORIFICE SIZE CHART FOR FIELD INSTALLED OPTION 22,500 BTU PER BURNER | | | | | | | | | |
|---|-----------------------|----------------------------|----------------------------|----------------------------|----------------------------|----------------------------|----------------------------|----------------------------|-----------------------------|
| Gas Heat * Value BTU/Cu. Ft. | Up to 2000 Feet | 2001 to 3000 Feet | 3001 to 4000 Feet | 4001 to 5000 Feet | 5001 to 6000 Feet | 6001 to 7000 Feet | 7001 to 8000 Feet | 8001 to 9000 Feet | 9001 to 10000 Feet |
| 800 - 849 | 2.50 | 2.45 | 2.45 | 2.40 | 2.35 | 2.30 | 2.25 | 2.20 | 2.15 |
| 880 - 899 | 2.50 | 2.40 | 2.35 | 2.30 | 2.30 | 2.25 | 2.20 | 2.15 | 2.10 |
| 900 - 949 | 2.40 | 2.30 | 2.30 | 2.25 | 2.20 | 2.20 | 2.15 | 2.10 | 2.05 |
| 950 - 999 | 2.35 | 2.25 | 2.25 | 2.20 | 2.20 | 2.15 | 2.10 | 2.05 | 2.00 |
| 1000 - 1049 | 2.30 | 2.20 | 2.20 | 2.15 | 2.10 | 2.10 | 2.05 | 2.00 | 1.95 |
| 1050-1100 | 2.25 | 2.15 | 2.15 | 2.10 | 2.10 | 2.05 | 2.00 | 1.95 | 1.90 |

* At standard conditions: 30.00 inches Mercury, 60F, saturated.

NOTE: **2.30** Orifices are shipped with the unit for field installed optional 10% input derate. **2.40** is the factory installed orifice size for full rated input. All other orifice sizes not shown with black background are available in U.S. Natural Gas High Altitude Kit, Bard Part No. GCK-US-N1. Orifice sizes shown with black background available separately.

CANADIAN INSTALLATIONS ONLY

Rating of gas utilization equipment is based on sea level operation and need not be changed for operation at elevations up to 2000 feet. For operation at elevations from 2001 to 4500 feet a main burner orifice change is

required in accordance with CAN/CGA-2.17-M91 Standard for Gas-Fired Appliances for Use at High Altitudes. See Table 8 for 2001-4500 feet altitude derate information, and for fuel gas BTU ratings from 800-1100 BTU per cubic foot.

**TABLE 8
HIGH ALTITUDE DERATE CHARTS
CANADIAN INSTALLATIONS ONLY**

| NATURAL GAS -- ORIFICE SIZE CHART FOR FACTORY STANDARD 25,000 BTU PER BURNER | | |
|---|--------------------------|----------------------------|
| Gas Heat * Value BTU/Cu. Ft. | Up to 2000 Feet | 2001 to 4500 Feet |
| 800 - 849 | 2.70 | 2.50 |
| 880 - 899 | 2.60 | 2.50 |
| 900 - 949 | 2.50 | 2.40 |
| 950 - 999 | 2.45 | 2.35 |
| 1000 - 1049 | 2.40 | 2.30 |
| 1050-1100 | 2.30 | 2.25 |

* At standard conditions: 30.00 inches Mercury, 60F, saturated.

NOTE: **2.40** Standard factory installed orifice size. **2.30** is shipped with the unit for field installed optional 10% derate. All orifice sizes not shown with a black background are available in Canadian Natural Gas High Altitude Kit, Bard Part No. GCK-CAN-N1. Orifice sizes with black background are available separately.

| NATURAL GAS -- ORIFICE SIZE CHART FOR FIELD INSTALLED OPTION 22,500 BTU PER BURNER | | |
|---|--------------------------|----------------------------|
| Gas Heat * Value BTU/Cu. Ft. | Up to 2000 Feet | 2001 to 4500 Feet |
| 800 - 849 | 2.50 | 2.40 |
| 880 - 899 | 2.50 | 2.35 |
| 900 - 949 | 2.40 | 2.30 |
| 950 - 999 | 2.35 | 2.25 |
| 1000 - 1049 | 2.30 | 2.20 |
| 1050-1100 | 2.25 | 2.10 |

* At standard conditions: 30.00 inches Mercury, 60F, saturated.

NOTE: **2.30** Orifices are shipped with the unit for field installed optional 10% input derate. **2.40** is the factory installed orifice size for full rated input. All other orifice sizes not shown with black background are available in U.S. Natural Gas High Altitude Kit, Bard Part No. GCK-US-N1. Orifice sizes shown on black background are available separately.

22. CONVERSION OF GAS INPUT BTUH FROM HIGH TO LOW RATING

All the derated WG series units are produced with maximum BTUH input orifices installed. To field convert input, a change to main burner orifices is required.

NOTE: *No change to air orifices is necessary. A set of low input orifices is shipped with every unit. They will be found packaged in a bag behind the burner door. Refer to the unit rating plate to confirm the proper orifice size. Proper installation of the orifices is detailed as follows:*

- A. Shut off electrical supply to the unit.
- B. Shut off gas supply to the unit.
- C. Remove burner access panel.
- D. Disconnect gas valve from gas supply piping.
- E. Disconnect the two wires from the gas valve.
- F. Remove the manifold assembly so that orifices are now accessible and remove orifices.
- G. Apply a modest amount of pipe compound to the new orifices and screw them into the manifold.
- H. To assemble burner reverse steps A through G.

WARNING

Failure to follow these instructions could create a hazard resulting in property damage, bodily injury, or death.

23. MEASURING AIR TEMPERATURE RISE

Air temperature rise (supply air temperature minus return air temperature) must be within allowable air temperature rise range specified on furnace rating plate and in Table 1.

You will need 2 thermometers with 1 degree resolution capable of reading up to 200 degrees F. Check thermometers to make sure they agree, or compensate accordingly.

Follow this procedure:

1. Open supply air registers and return air grilles. Make sure the registers and grilles are free of obstruction from rugs, carpets, drapes or furniture.

2. Set balancing dampers in supply duct system.
3. Check duct work for obstructions or leaks.
4. Make sure filters are clean and in place.
5. Place one thermometer in supply air plenum approximately 2 feet from furnace. Locate thermometer tip in center of plenum to ensure proper temperature measurement.
6. Place second thermometer in return air duct approximately 2 feet from furnace. Locate thermometer tip in center of duct to ensure proper temperature measurement.
7. Set room thermostat on highest temperature setting. Operate furnace 10 minutes. Record supply air and return air temperatures.
8. Calculate air temperature rise by subtracting return air temperature from supply air temperature.
 - If air temperature rise is above the temperature rise range on rating plate, furnace is overfired or has insufficient airflow. Check gas input following the instructions in Section , "Checking Gas Input Rate". If air temperature rise is still above temperature rise range specified, more heating air flow is needed. Check duct work and grilles to make sure all are properly sized.
 - If air temperature rise is below the temperature rise range on rating plate, furnace is underfired or has too much airflow. Check gas input following the instructions in Section , "Checking Gas Input Rate". If air temperature rise is still below temperature rise range specified, less heating air flow is needed. Adjust dampers or grilles as needed.
 - After making adjustments, you must check air temperature rise to verify that resulting air temperature rise is within allowable range. If air temperature rise is still outside the temperature rise range specified on rating plate, check duct system design with a qualified heating engineer. It may be necessary to re-size the duct work. Recheck air temperature rise after revising duct systems.

9. Set room thermostat to desired setting.

10. Remove thermometers and seal duct work holes.

NOTE: *Failure to seal holes could result in reduced system performance.*

24. FILTERS

A 20 x 30 x 2 throwaway filter is supplied with each unit. This filter is installed by opening the main service door. (See Figure 3.)

There is also an 8 x 26 x 1/2 washable filter that is a part of Fresh Air Damper (FAD) assembly. This filter cleans the outside air being introduced through the FAD.

Replacement filters are available through your dealer.

25. COMPRESSOR CONTROL MODULE

The compressor control is an anti-short cycle/lockout timer with high and low pressure switch monitoring and alarm output.

ADJUSTABLE DELAY-ON-MAKE AND BREAK TIMER

On a call for compressor operation the *delay-on-make* period begins which will be 10% of the *delay-on-break* setting. When the delay-on-make is complete and the high pressure switch (and low pressure switch if employed) is closed, the compressor contactor is energized. Upon shutdown the delay-on-break timer starts and prevents restart until the delay-on-break and delay-on-make periods have expired.

HIGH PRESSURE SWITCH AND LOCKOUT SEQUENCE (Standard Feature)

If the high pressure switch opens, the compressor contactor will de-energize immediately. The lockout timer will go into a *soft lockout* and stay in soft lockout until the high pressure switch closes **and** the delay-on-make time has expired. If the high pressure switch opens again in this same operating cycle the unit will go into *manual lockout* condition and the alarm circuit will energize. Recycling the wall thermostat resets the manual lockout.

LOW PRESSURE SWITCH, BYPASS, AND LOCKOUT SEQUENCE

NOTE: The low pressure switch is an optional control and the bypass and lockout sequence are part of the standard compressor control module.

If the low pressure switch opens for more than 120 seconds, the compressor contactor will de-energize and go into a soft lockout. Regardless the state of the low pressure switch, the contactor will reenergize after the delay-on-make time delay has expired. If the low pressure switch remains open or opens again for longer

than 120 seconds the unit will go into manual lockout condition and the alarm circuit will energize. Recycling the wall thermostat resets the manual lockout.

ALARM OUTPUT

Alarm terminal is output connection for applications where alarm signal is desired. This terminal is powered whenever compressor is locked out due to HPC or LPC sequences as described.

NOTE: Both high and low pressure switch controls are inherently automatic reset devices. The high pressure switch and low pressure switch cut out and cut in settings are fixed by specific air conditioner or heat pump unit model. The lockout features, both soft and manual, are a function of the Compressor Control Module.

ADJUSTMENTS

ADJUSTABLE DELAY-ON-MAKE AND DELAY-ON-BREAK TIMER

The potentiometer is used to select Delay-on-Break time from 30 seconds to 5 minutes. Delay-on-Make (DOM) timing on power-up and after power interruptions is equal to 2 minutes plus 10% of Delay-on-Break (DOB) setting:

| | | |
|--------------------------|------------------|-----|
| 0.5 minute (30 seconds) | DOB = 123 second | DOM |
| 1.0 minute (60 seconds) | DOB = 126 second | DOM |
| 2.0 minute (120 seconds) | DOB = 132 second | DOM |
| 3.0 minute (160 seconds) | DOB = 138 second | DOM |
| 4.0 minute (240 seconds) | DOB = 144 second | DOM |
| 5.0 minute (300 seconds) | DOB = 150 second | DOM |

PHASE MONITOR

All units with three phase scroll compressors are equipped with a three phase line monitor to prevent compressor damage due to phase reversal.

The phase monitor in this unit is equipped with two LEDs. If the “&” signal is present at the phase monitor and phases are correct, the green LED will light.

If phases are reversed, the red fault LED will be lit and compressor operation is inhibited.

If a fault condition occurs, reverse two of the supply leads to the unit. Do not reverse any of the unit factory wires as damage may occur.

26. LIGHTING AND SHUTDOWN INSTRUCTIONS

FIGURE 14
INSTRUCTION LABEL

FOR YOUR SAFETY READ BEFORE OPERATING

WARNING: If you do not follow these instructions exactly, a fire or explosion may result causing property damage, personal injury or loss of life.

- A. This appliance does not have a pilot. It is equipped with an ignition device which automatically lights the burner. Do NOT try to light the burner by hand.
- B. BEFORE OPERATING smell all around the appliance area for gas. Be sure to smell next to the floor because some gas is heavier than air and will settle on the floor.

WHAT TO DO IF YOU SMELL GAS

- * Do not try to light any appliance.
- * Do not touch any electric switch, do not use any phone in your building.
- * Immediately call your supplier from a neighbor's phone. Follow the gas supplier's instructions.

* If you cannot reach your gas supplier, call the fire department.

- C. Use only your hand to push in or move the gas control lever. Never use tools. If the lever will not push in or turn by hand, don't try to repair it, call a qualified service technician. Force or attempted repair may result in a fire or explosion.
- D. Do not use this appliance if any part has been under water. Immediately call a qualified service technician to inspect the appliance and to replace any part of the control system and any gas control which has been under water.

OPERATING INSTRUCTIONS

1. STOP! Read the safety information above on this label.
2. Set the thermostat to lowest setting.
3. Turn off all electric power to the appliance.
4. This appliance is equipped with an ignition device which automatically lights the burner. Do NOT try to light the burner by hand.

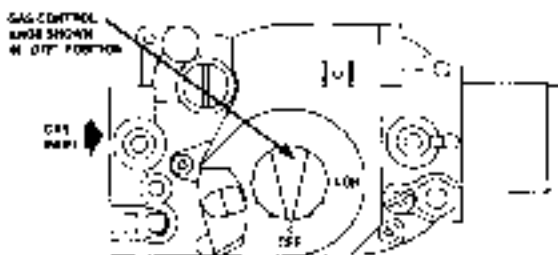

5. Remove control access panel.
6. Push in gas control knob slightly and turn clockwise to "OFF".
NOTE: Knob cannot be turned to "OFF" unless knob is pushed in slightly. Do not force.
7. Wait five (5) minutes to clear out any gas. Then smell for gas, including near the floor. If you smell gas, STOP! Follow "B" in the safety information above on this label. If you don't smell gas, go to the next step.
8. Turn gas control knob counterclockwise to "ON".
9. Replace control access panel.
10. Turn on all electric power to the appliance.
11. Set thermostat to desired setting.
12. If the appliance will not operate, follow the instructions "To Turn Off Gas To Appliance" and call your service technician or gas supplier.

TO TURN OFF GAS TO APPLIANCE

1. Set the thermostat to lowest setting.
2. Turn off all electric power to the appliance if service is to be performed.
3. Remove control access panel.
4. Push in gas control lever slightly and move to "OFF". Do not force.
5. Replace control access panel.

7961-509

27. SERVICE AGENCY PROCEDURES

CAUTION

Label all wires prior to disconnection when servicing controls. Wiring errors can cause improper and dangerous operation. Verify proper operation after servicing.

WARNING

Follow these procedures before inspecting furnace.

- Turn room thermostat to its lowest or off setting.
- Turn off manual gas shut-off valve.
- Wait at least 5 minutes for furnace to cool if it was recently operating.
- Turn off furnace electrical power; failure to do so could result in injury or death.

MAIN BURNER

Observe the main burners in operation. The flame should be mostly “blue” with possibly a little orange (not yellow) at the tips of the flame. The flames should be in the center of the heat exchanger tubes and not impinging on the heat exchanger surfaces themselves.

Observe the fire until the blower starts (there is a normal delay period until the heat exchanger warms up). There should be no change in the size or shape of the flame. If there is any wavering or blowing of the flame on blower start-up, it is an indication of a possible leak in the heat exchanger.

FIGURE 15
TOP VIEW OF GAS CONTROL

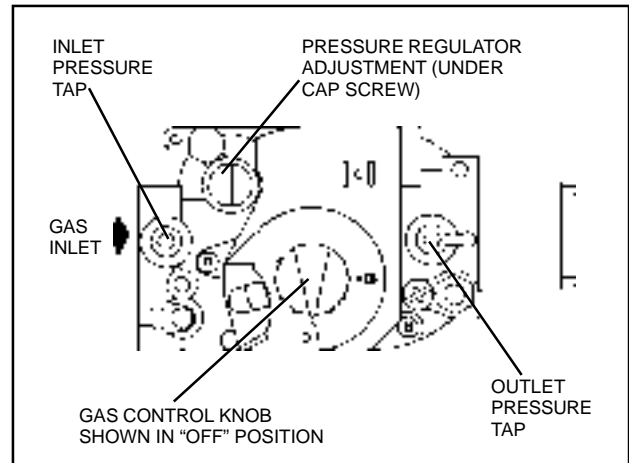

BURNERS / HEAT EXCHANGER / FLUE GAS PASSAGEWAYS

The burners, heat exchanger and interior flue gas passages may be inspected using a light on small mirror or an extension handle. Remove the screws securing the inducer and collector box. Now inspect the upper tubes of the heat exchanger.

Check the exterior of the heat exchanger and the interior flue gas passages for any evidence of deterioration due to corrosion, cracking or other causes. If signs of sooting exist, remove the burners and clean the heat exchanger, as required.

28. MAINTAINING UNIT IN GOOD WORKING ORDER

The unit should be inspected annually by a qualified service agency.

WARNING

Use replacement parts listed in the Replacement Parts list only. The use of incorrect parts could cause improper unit operation, resulting in damage, injury or death.

WARNING

Disconnect electrical power before servicing unit. Failure to do so could result in electrical shock or death.

ANNUAL MAINTENANCE

Routine inspection and maintenance procedures are the responsibility of the user and are outlined below.

1. Before inspecting unit:
 - a. Turn room thermostat to lowest or off setting.
 - b. Turn off equipment gas shut-off valve.
 - c. Wait for unit to cool if it was recently operating.
 - d. Turn off electrical power to unit.
2. Inspect the following:
 - a. Vent terminal and combustion air intake terminal. Make sure both are free from obstructions.
 - b. Vertical Vent Applications – Inspect venting system. Make sure system has no holes, is physically sound and free from obstructions.
 - c. Make sure the supply and return air flange sleeves or duct work are securely fastened to unit and physically sound.
 - d. Supply and return grilles must be open and free from obstructions.
 - e. Inspect to make sure the unit is securely fastened to the wall. Seal any possible leaks between unit and wall with appropriate exterior sealing material.
 - f. Inspect burners, heat exchanger, induced draft blower, and induced draft blower collector box. There must be no obvious signs of deterioration.
 - g. Inspect all electrical connections and wiring.
 - h. Check all gas piping for leaks with soap solution used to detect leaks.
 - i. Inspect, clean, and repair as needed the entire blower assembly, air filters, draft inducer, cooling coils, and vent options (if installed).

ROUTINE MAINTENANCE

1. Air Filters – Check the condition at least monthly when the unit is in use, and replace as necessary.
2. Lubrication Requirements – The indoor circulating air blower motor and outdoor circulating air fan motor are permanently lubricated and require no re-oiling. The combustion air blower motor requires no re-oiling.

WARNING

Turn off electrical power supply to prevent injury from moving parts or electric shock.

ROUTINE INSPECTION

1. Inspect the physical support of the unit annually to make sure it is securely fastened to the building. Also look for any obvious signs of deterioration.
2. Inspect the main burners at the beginning of each heating season and clean as necessary.
3. Inspect the vent terminal and combustion air intake hood for any obvious deterioration, to make sure it is free and clear of any obstructions.

29. REPLACEMENT PARTS

WARNING

Use replacement parts listed in Replacement Parts list. Failure to do so could cause improper furnace operation, resulting in property damage, personal injury, or death.

Replacement parts for the gas/electric units are available through local distributors.

A replacement parts list manual is supplied with each unit. When ordering parts or making inquiries pertaining to any of the units covered by these instructions, it is very important to always supply the *complete* model number and serial number of the unit. This is necessary to assure that the correct parts (or an approved alternate part) are issued to the service agency.

30. SEQUENCE OF OPERATION – HEATING

On a call for heat from the thermostat, the induced draft blower is energized. Once sufficient draft is established, the pressure switch contacts close and the ignition system is energized. The direct spark ignitor will be energized allowing gas to flow. At the same time the main valve is energized, a 30 second blower delay timer is activated.

After this delay, the heating speed blower relay energizes. The blower will begin operating and remain in operation until the set delay time after the call for heat has been satisfied. (See Table 12 for selectable blower off time delays.) This timing sequence guarantees blower on, blower off operation.

This unit is equipped with a flame rollout switch which is wired in series with the control circuit. This is a manual reset switch and is used for the purpose of preventing possible fire hazard in the event of a system malfunction. If this switch has opened the control circuit, there could be a possible system malfunction. Some of the conditions that might cause a rollout to occur are blockage or sooting of primary heat exchanger, overfiring of furnace due to improper main burner orifices or incorrect manifold pressure, insufficient combustion air, or installation deficiencies with respect to return air duct design or sizing.

Once the problem has been resolved, reset the switch by pressing down on the reset button on top of the switch. See Figure 16 for additional information.

31. SEQUENCE OF OPERATION – COOLING

On a call for cooling from the room thermostat, the high speed blower relay will be energized as well as the compressor contactor. Following termination of the cooling cycle, the blower motor will continue to run for one minute.

See Figure 16 for additional information.

DEHUMIDIFICATION – Dehumidification is controlled through a humidistat and is independent of the thermostat. On a call for dehumidification mode of operation the compressor and three way valve of the unit are energized through circuit R - F to provide dehumidification. Dehumidification will continue until the humidistat is satisfied.

Any time there is a call for cooling mode of operation through circuit R - Y the dehumidification mode will cancel and the system will return to cooling operation

Any time there is a call for heating mode of operation through circuit R-W1 the dehumidification mode will cancel and the system will return to heating operation. Dehumidification is delayed 45-60 seconds on start up after any heating cycle is complete.

Any time the indoor coil temperature falls below 32 degrees the compressor will be de-energized until the coil temperature rises above 57 degrees.

If the room temperature falls below 65 degrees the dehumidification mode will discontinue until the room temperature rises above 72 degrees.

FIGURE 16
SEQUENCE OF OPERATION
ELECTRONIC BLOWER CONTROL

| ACTION | SYSTEM RESPONSE |
|---|--|
| Thermostat calls for heat. (W terminal is energized.) | <ul style="list-style-type: none"> • Combustion air blower is energized. • Air proving switch makes. Air flow is established. • Ignition system is energized. • Gas valve opens and main burner lights. • Heat fan on delay timing begins. When timing is complete, the circulating fan is energized at heat speed. |
| Thermostat ends call for heat. | <ul style="list-style-type: none"> • Ignition system is de-energized and gas valve closes. • Combustion air blower is de-energized after postpurge timing. • Heat fan off delay timing begins. When timing is complete, the circulating fan is de-energized. |
| Thermostat begins call for cool. (G and Y terminals energized.) | <ul style="list-style-type: none"> • Cooling contactor is energized. • Circulating fan is energized on cool speed after 7 second cool fan on delay timing. |
| Thermostat ends call for cooling. | <ul style="list-style-type: none"> • Cooling contactor is de-energized. • Cooling fan off delay timing begins. • After 60 seconds the circulating fan is de-energized. |
| Thermostat begins call for manual fan. (G terminal is energized.) | <ul style="list-style-type: none"> • Circulating fan is energized on heating speed. |
| Thermostat ends call for manual fan. | <ul style="list-style-type: none"> • Circulating fan is de-energized. |
| Limit (flame rollout) opens. | <ul style="list-style-type: none"> • Thermostat and ignition system are de-energized and gas valve closes. • Combustion air blower and circulating fan heat speed are energized. |
| Limit (auto reset) or flame rollout (manual reset) circuit closed. | <ul style="list-style-type: none"> • Combustion air blower remains energized for postpurge timing. • The circulation fan remains energized for the selected delay off timing. • Normal operation resumes. |

FIGURE 18
460 VOLT BLOWER MOTOR WIRING OPTIONS

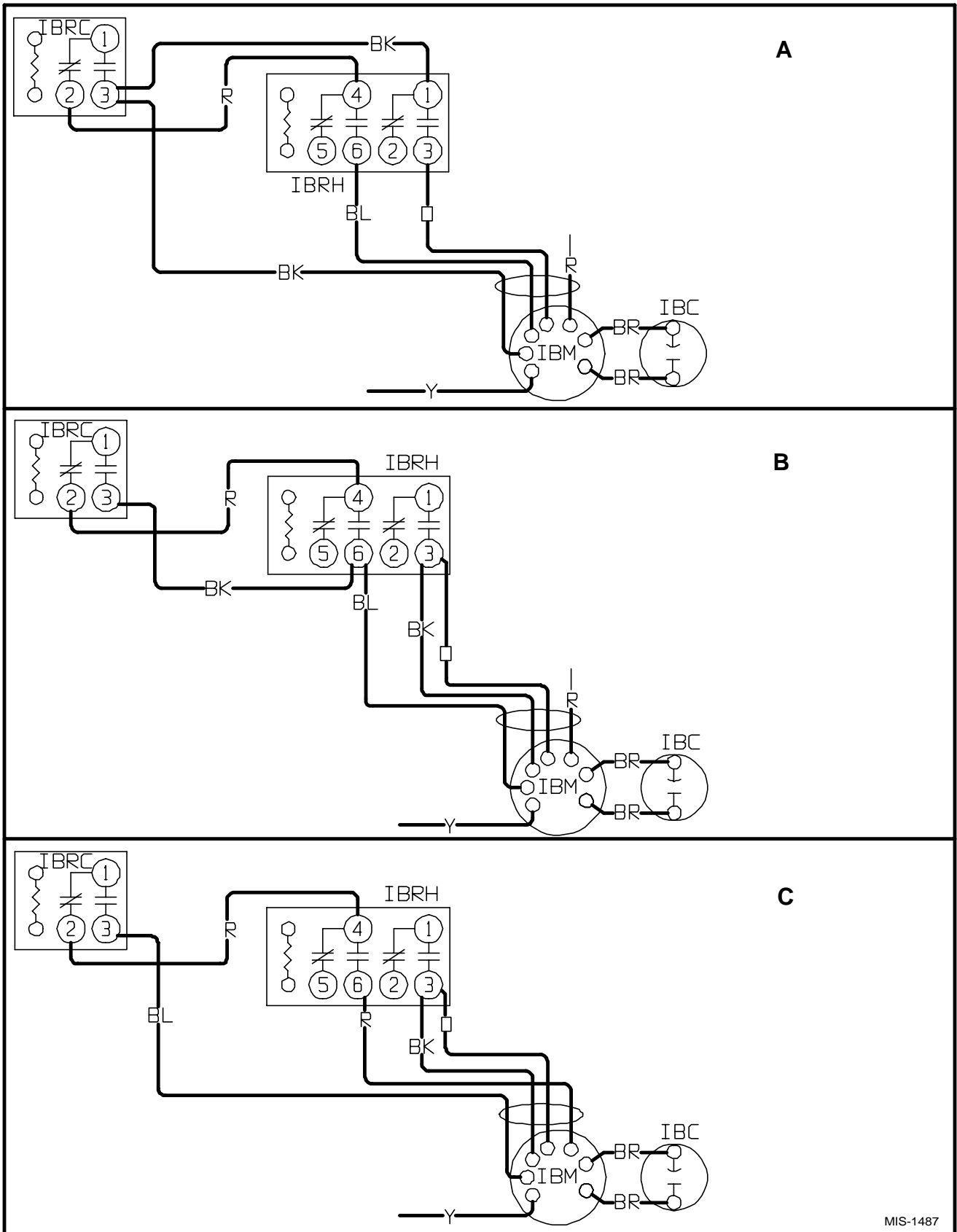

MIS-1487

**TABLE 9
WG421 INDOOR BLOWER PERFORMANCE @ 230 AND 460 VOLTS**

Recommended WG421 cooling airflow range at rated 1300 CFM @ .35 ESP (WC) is 1500 - 1030 CFM

Factory set on Medium Speed for heating and cooling

| ESP Inches H _s O | COOLING MODE | | | MANUAL FAN and HEATING MODE | | | | | |
|-----------------------------------|--------------|--------|------|-----------------------------|--------|------|-------------------|--------|------|
| | Wet Coil | | | 125,000 BTU Input | | | 112,500 BTU Input | | |
| | High | Medium | Low | High | Medium | Low | High | Medium | Low |
| .00 | --- | 1540 | 1140 | --- | 1640 | 1230 | --- | 1640 | 1230 |
| .10 | --- | 1480 | 1090 | --- | 1580 | 1180 | --- | 1580 | 1180 |
| .20 | --- | 1410 | 1030 | 1880 | 1510 | --- | --- | 1510 | 1090 |
| .30 | --- | 1360 | --- | 1760 | 1460 | --- | --- | 1460 | --- |
| .40 | --- | 1250 | --- | 1670 | 1340 | --- | 1670 | 1340 | --- |
| .50 | 1460 | 1150 | --- | 1560 | 1240 | --- | 1560 | 1240 | --- |
| .60 | 1340 | 1040 | --- | 1430 | 1130 | --- | 1430 | 1130 | --- |

| ESP Inches H _s O | COOLING MODE | | | MANUAL FAN and HEATING MODE | | | | | |
|-----------------------------------|--------------|--------|------|-----------------------------|--------|------|------------------|--------|------|
| | Wet Coil | | | 100,000 BTU | | | 90,000 BTU Input | | |
| | High | Medium | Low | High | Medium | Low | High | Medium | Low |
| .00 | --- | --- | 1190 | --- | 1690 | 1280 | --- | 1690 | 1280 |
| .10 | --- | 1530 | 1140 | --- | 1630 | 1230 | --- | 1630 | 1230 |
| .20 | --- | 1460 | 1070 | --- | 1560 | 1160 | --- | 1560 | 1160 |
| .30 | --- | 1410 | 1050 | 1810 | 1510 | 1140 | --- | 1510 | 1140 |
| .40 | --- | 1300 | --- | 1720 | 1390 | --- | 1720 | 1390 | 1020 |
| .50 | 1510 | 1200 | --- | 1610 | 1290 | --- | 1610 | 1290 | 970 |
| .60 | 1390 | 1090 | --- | 1480 | 1180 | --- | 1480 | 1180 | --- |

| ESP Inches H _s O | COOLING MODE | | | MANUAL FAN and HEATING MODE | | | | | |
|-----------------------------------|--------------|--------|------|-----------------------------|--------|------|------------------|--------|------|
| | Wet Coil | | | 75,000 BTU Input | | | 67,500 BTU Input | | |
| | High | Medium | Low | High | Medium | Low | High | Medium | Low |
| .00 | --- | --- | 1240 | --- | 1740 | 1330 | --- | 1740 | 1330 |
| .10 | --- | --- | 1190 | --- | 1680 | 1280 | --- | 1680 | 1280 |
| .20 | --- | 1510 | 1120 | --- | 1610 | 1210 | --- | 1610 | 1210 |
| .30 | --- | 1460 | 1100 | 1860 | 1560 | 1190 | --- | 1560 | 1190 |
| .40 | --- | 1340 | --- | 1770 | 1440 | 1070 | --- | 1440 | 1070 |
| .50 | --- | 1260 | --- | 1660 | 1340 | 970 | 1660 | 1340 | 970 |
| .60 | 1440 | 1140 | --- | 1530 | 1230 | --- | 1530 | 1230 | --- |

Voltage adjustment – Reduce airflow by 130 CFM for 208 Volt

Dehumidification coil adjustment – Reduce airflow by 20 CFM for dehumidification models

Top outlet adjustment – Increase airflow by 65 CFM for top outlet models

SG-5, RG-5, non-ducted application adjustment – Reduce airflow by 170 CFM for SG-5 and RG-5 installations

**TABLE 10
WG481 INDOOR BLOWER PERFORMANCE @ 230 AND 460 VOLTS**

Recommended WG481 cooling airflow range at rated 1550 CFM @ .38 ESP (WC) is 1750 - 1280 CFM

Factory set on High Speed for cooling and Medium Speed for heating.

| ESP Inches H _s O | COOLING MODE | | | MANUAL FAN and HEATING MODE | | | | | |
|-----------------------------------|--------------|--------|-----|-----------------------------|--------|------|-------------------|--------|------|
| | Wet Coil | | | 125,000 BTU Input | | | 112,500 BTU Input | | |
| | High | Medium | Low | High | Medium | Low | High | Medium | Low |
| .00 | --- | 1540 | --- | --- | 1640 | 1230 | --- | 1640 | 1230 |
| .10 | --- | 1480 | --- | --- | 1580 | 1180 | --- | 1580 | 1180 |
| .20 | 1780 | 1410 | --- | 1880 | 1510 | --- | --- | 1510 | 1110 |
| .30 | 1670 | 1360 | --- | 1760 | 1460 | --- | --- | 1460 | 1090 |
| .40 | 1570 | 1250 | --- | 1670 | 1340 | --- | 1670 | 1340 | --- |
| .50 | 1460 | --- | --- | 1560 | 1240 | --- | 1560 | 1240 | --- |
| .60 | 1340 | --- | --- | 1430 | --- | --- | 1430 | 1130 | --- |

| ESP Inches H _s O | COOLING MODE | | | MANUAL FAN and HEATING MODE | | | | | |
|-----------------------------------|--------------|--------|-----|-----------------------------|--------|------|------------------|--------|------|
| | Wet Coil | | | 100,000 BTU | | | 90,000 BTU Input | | |
| | High | Medium | Low | High | Medium | Low | High | Medium | Low |
| .00 | --- | 1590 | --- | --- | 1690 | 1280 | --- | 1690 | 1280 |
| .10 | --- | 1530 | --- | --- | 1630 | 1230 | --- | 1630 | 1230 |
| .20 | --- | 1460 | --- | --- | 1560 | 1160 | --- | 1560 | 1160 |
| .30 | 1700 | 1410 | --- | 1810 | 1510 | 1140 | --- | 1510 | 1140 |
| .40 | 1620 | 1300 | --- | 1720 | 1390 | --- | 1720 | 1390 | 1020 |
| .50 | 1510 | --- | --- | 1610 | 1290 | --- | 1610 | 1290 | 970 |
| .60 | 1390 | --- | --- | 1480 | 1180 | --- | 1480 | 1180 | --- |

| ESP Inches H _s O | COOLING MODE | | | MANUAL FAN and HEATING MODE | | | | | |
|-----------------------------------|--------------|--------|------|-----------------------------|--------|------|------------------|--------|------|
| | Wet Coil | | | 75,000 BTU Input | | | 67,500 BTU Input | | |
| | High | Medium | Low | High | Medium | Low | High | Medium | Low |
| .00 | --- | --- | 1640 | --- | 1740 | 1330 | --- | 1740 | 1330 |
| .10 | --- | 1580 | --- | --- | 1680 | 1280 | --- | 1680 | 1280 |
| .20 | --- | 1510 | --- | --- | 1610 | 1210 | --- | 1610 | 1210 |
| .30 | 1750 | 1460 | --- | 1860 | 1560 | 1190 | --- | 1560 | 1190 |
| .40 | 1670 | 1340 | --- | 1770 | 1440 | 1070 | --- | 1440 | 1070 |
| .50 | 1560 | 1260 | --- | 1660 | 1340 | 970 | 1660 | 1340 | 970 |
| .60 | 1440 | --- | --- | 1530 | 1230 | --- | 1530 | 1230 | --- |

Voltage adjustment – Reduce airflow by 130 CFM for 208 Volt

Dehumidification coil adjustment – Reduce airflow by 20 CFM for dehumidification models

Top outlet adjustment – Increase airflow by 65 CFM for top outlet models

SG-5, RG-5, non-ducted application adjustment – Reduce airflow by 170 CFM for SG-5 and RG-5 installations

**TABLE 11
WG601 INDOOR BLOWER PERFORMANCE @ 230 AND 460 VOLTS**

Recommended WG601 cooling airflow range at rated 1650 CFM @ .30 ESP (WC) is 1910 - 1340 CFM
Factory set on High Speed for cooling and Medium Speed for heating.

| ESP Inches H _s O | COOLING MODE | | | MANUAL FAN and HEATING MODE | | | | | |
|-----------------------------------|--------------|--------|-----|-----------------------------|--------|------|-------------------|--------|------|
| | Wet Coil | | | 125,000 BTU Input | | | 112,500 BTU Input | | |
| | High | Medium | Low | High | Medium | Low | High | Medium | Low |
| .00 | 1930 | 1540 | --- | --- | 1640 | 1230 | --- | 1640 | 1230 |
| .10 | 1850 | 1480 | --- | --- | 1580 | 1180 | --- | 1580 | 1180 |
| .20 | 1780 | 1410 | --- | 1880 | 1510 | --- | --- | 1510 | 1110 |
| .30 | 1670 | 1360 | --- | 1760 | 1460 | --- | --- | 1460 | 1090 |
| .40 | 1570 | --- | --- | 1670 | 1340 | --- | 1670 | 1340 | --- |
| .50 | 1460 | --- | --- | 1560 | 1240 | --- | 1560 | 1240 | --- |
| .60 | 1340 | --- | --- | 1430 | --- | --- | 1430 | 1130 | --- |

| ESP Inches H _s O | COOLING MODE | | | MANUAL FAN and HEATING MODE | | | | | |
|-----------------------------------|--------------|--------|-----|-----------------------------|--------|------|------------------|--------|------|
| | Wet Coil | | | 100,000 BTU | | | 90,000 BTU Input | | |
| | High | Medium | Low | High | Medium | Low | High | Medium | Low |
| .00 | --- | 1590 | --- | --- | 1690 | 1280 | --- | 1690 | 1280 |
| .10 | 1900 | 1530 | --- | --- | 1630 | 1230 | --- | 1630 | 1230 |
| .20 | 1830 | 1460 | --- | --- | 1560 | 1160 | --- | 1560 | 1160 |
| .30 | 1700 | 1410 | --- | 1810 | 1510 | 1140 | --- | 1510 | 1140 |
| .40 | 1620 | --- | --- | 1720 | 1390 | --- | 1720 | 1390 | 1020 |
| .50 | 1510 | --- | --- | 1610 | 1290 | --- | 1610 | 1290 | 970 |
| .60 | 1390 | --- | --- | 1480 | 1180 | --- | 1480 | 1180 | --- |

| ESP Inches H _s O | COOLING MODE | | | MANUAL FAN and HEATING MODE | | | | | |
|-----------------------------------|--------------|--------|-----|-----------------------------|--------|------|------------------|--------|------|
| | Wet Coil | | | 75,000 BTU Input | | | 67,500 BTU Input | | |
| | High | Medium | Low | High | Medium | Low | High | Medium | Low |
| .00 | --- | 1640 | --- | --- | 1740 | 1330 | --- | 1740 | 1330 |
| .10 | 1950 | 1580 | --- | --- | 1680 | 1280 | --- | 1680 | 1280 |
| .20 | 1880 | 1510 | --- | --- | 1610 | 1210 | --- | 1610 | 1210 |
| .30 | 1750 | 1460 | --- | 1860 | 1560 | 1190 | --- | 1560 | 1190 |
| .40 | 1670 | 1340 | --- | 1770 | 1440 | 1070 | --- | 1440 | 1070 |
| .50 | 1560 | --- | --- | 1660 | 1340 | 970 | 1660 | 1340 | 970 |
| .60 | 1440 | --- | --- | 1530 | 1230 | --- | 1530 | 1230 | --- |

Voltage adjustment – Reduce airflow by 130 CFM for 208 Volt

Dehumidification coil adjustment – Reduce airflow by 20 CFM for dehumidification models

Top outlet adjustment – Increase airflow by 65 CFM for top outlet models

SG-5, RG-5, non-ducted application adjustment – Reduce airflow by 170 CFM for SG-5 and RG-5 installations

TABLE 12 INTEGRATED FURNACE AND BLOWER CONTROL OPERATION

IGNITION SEQUENCE CONTROL

| | |
|----------------------------------|--|
| Ignition Source | 24 VAC DSI |
| Flame Sensing | Remote |
| Timings | |
| - Prepurge | 15 seconds |
| - Postpurge | 30 seconds (0 if cycle terminated before valve "on") |
| - Inter-trial purge | 15 seconds |
| - Pressure switch proving period | 60 seconds |
| - Trials for ignition | 3 per ignition sequence |
| - Trial for ignition | 7 seconds total time to prove flame |
| - Ignition sequence lockout | 60 minutes (after 3 trials for ignition), auto reset - can be reset during the 60 minute lockout period by opening thermostat circuit for 3 seconds or more |
| - Heat blower on - delay | 30 seconds (timing starts when ignitor cycles off) |
| - Heat blower off - delay | 90, 120, 150 seconds selectable; factory set at 120 |
| - Cool blower on - delay | 7 seconds |
| - Cool blower off - delay | 60 seconds |
| - Manual fan operations | Operates on selected heating speed and cycles off during |
| - High limit control operation | Automatic reset, ignition sequence restart. See Note 1. |
| - Flame rollout switch operation | Manual reset, ignition sequence initiated after switch is manually reset. See Note 1. |

NOTE 1: After the fourth limit trip on a given call for heat there will be a 1 hour delay before the ignition sequence will restart. After either high limit switch or flame rollout switch actuation the inducer will operate for the 30 second post purge and the comfort air blower will operate for the selected off delay. If on Manual Fan operation, the comfort air blower will continue to operate.

SAFETY UNITS

| | |
|---|---|
| High limit / Rollout Pressure switch | SPST in 24 Volt SPST, safe start check |
|---|---|

COMFORT FAN CONTROL

Heating Speed Fan

| | |
|------------------|---|
| Normal operation | |
| - ON delay | 30 seconds fixed. Timing starts when igniter de-energized |
| - OFF delay | 3 selectable timings -120 seconds standard can be changed to 90 or 150 seconds. |
| Limit Operation | ON when limit OPEN OFF after OFF delay when limit CLOSES |
| Flame Sense | ON if flame is sensed and there is no call for heat. |

Cooling Speed Fan

| | |
|-------------|------------|
| - ON delay | 7 seconds |
| - OFF delay | 60 seconds |

Manual Fan

ON continuously on HEATING speed. When call for cool, the fan switches to COOLING speed. Then when thermostat satisfied, the fan switches back to HEATING speed after COOLING OFF delay.

DIAGNOSTIC INDICATOR

A red LED is provided to indicate system faults as follows:

- Steady ON - Control okay in standby, call for heat, cool or fan modes
 - Steady OFF - Internal control fault or no power. Also check 3A fuse on control.
 - 1 flash - Lockout due to failed ignition or flame dropouts
 - 2 flashes - Pressure switch open with inducer on
 - 3 flashes - Pressure switch is closed with inducer off
 - 4 flashes - Limit switch is open
 - 5 flashes - Flame detected with gas valve closed
 - 6 flashes - Compressor output delayed from short cycle/staging timer
- The flash rate is 0.25 seconds on, 0.25 seconds off with 2.0 seconds pause between flash codes.

33. PRESSURE SERVICE PORTS

High and low pressure service ports are installed on all units so that the system operating pressures can be observed. Table 13 outlines expected pressures at various indoor and outdoor temperatures.

**TABLE 13
COOLING PRESSURE TABLE**

| Model | Return Air Temperature | Pressure | 75 | 80 | 85 | 90 | 95 | 100 | 105 | 110 | 115 |
|-------|------------------------|-----------|-----|-----|-----|-----|-----|-----|-----|-----|-----|
| WG421 | 75 deg. DB | Low Side | 66 | 69 | 71 | 73 | 75 | 76 | 78 | 79 | 81 |
| | 62 deg. WB | High Side | 206 | 221 | 236 | 251 | 267 | 282 | 300 | 315 | 332 |
| | 80 deg. DB | Low Side | 72 | 74 | 76 | 78 | 80 | 81 | 84 | 85 | 87 |
| WG481 | 67 deg. WB | High Side | 211 | 226 | 242 | 257 | 274 | 290 | 307 | 323 | 341 |
| | 85 deg. DB | Low Side | 78 | 80 | 82 | 84 | 86 | 87 | 89 | 91 | 93 |
| | 72 deg. WB | High Side | 219 | 234 | 250 | 266 | 283 | 299 | 316 | 334 | 352 |
| WG601 | 75 deg. DB | Low Side | 69 | 70 | 72 | 73 | 74 | 75 | 76 | 77 | 79 |
| | 62 deg. WB | High Side | 199 | 214 | 229 | 244 | 261 | 278 | 294 | 312 | 331 |
| | 80 deg. DB | Low Side | 74 | 75 | 76 | 78 | 79 | 80 | 82 | 83 | 85 |
| WG601 | 67 deg. WB | High Side | 205 | 220 | 235 | 251 | 268 | 285 | 302 | 321 | 340 |
| | 85 deg. DB | Low Side | 80 | 81 | 83 | 84 | 85 | 86 | 88 | 89 | 91 |
| | 72 deg. WB | High Side | 210 | 226 | 242 | 259 | 277 | 294 | 314 | 332 | 352 |
| WG601 | 75 deg. DB | Low Side | 69 | 70 | 72 | 73 | 74 | 75 | 76 | 77 | 79 |
| | 62 deg. WB | High Side | 231 | 248 | 265 | 283 | 301 | 319 | 338 | 356 | 376 |
| | 80 deg. DB | Low Side | 74 | 75 | 76 | 77 | 79 | 80 | 81 | 82 | 84 |
| WG601 | 67 deg. WB | High Side | 237 | 254 | 272 | 290 | 309 | 327 | 346 | 366 | 386 |
| | 85 deg. DB | Low Side | 80 | 81 | 82 | 83 | 85 | 86 | 87 | 88 | 90 |
| | 72 deg. WB | High Side | 245 | 263 | 282 | 300 | 320 | 339 | 360 | 379 | 399 |

Low side pressure \pm 2 PSIG
High side pressure \pm 5 PSIG

34. DEHUMIDIFICATION CIRCUIT

The dehumidification circuit incorporates an independent heat exchanger coil in the supply air stream. This coil reheats the supply air after it passes over the cooling coil without requiring the gas burner to be used for reheat purposes. This results in very high mechanical dehumidification capability from the air conditioner on demand without using gas reheat.

The dehumidification refrigerant reheat circuit is controlled by a three way valve directing the refrigerant gas to the normal condenser during periods when standard air conditioning is required. During periods of time of low ambient temperature (approximately 65° to 75° outdoor) and high indoor humidity, a humidistat senses the need for mechanical dehumidification. It then energizes both the compressor circuit and the three way valve, thus directing the hot refrigerant discharge gas into a separate desuperheating condenser circuit

which reheats the conditioned air before it is delivered to the room. The refrigerant gas is then routed from the desuperheating condenser to the system condenser for further heat transfer. A small orifice inserted between the reheat coil return line and suction line will prevent liquid from accumulating in the reheat coil when it is inactive. This drain does not affect the normal operation of the system. A check valve is located in the reheat oil return line. It has a soft spring to hold the ball on the seat. This will make the method of checking the ball freedom with a magnet difficult. Refer to Figure 19 for the location of the check valve and drain back capillary. When the humidistat is satisfied, the system automatically switches back to normal air conditioning mode and either continues to operate or turns off based on the signal from the wall thermostat. The result is separate humidity control at minimum operating cost.

**FIGURE 19
LOW VOLTAGE WIRING
UNIT 24V TERMINAL BLOCK**

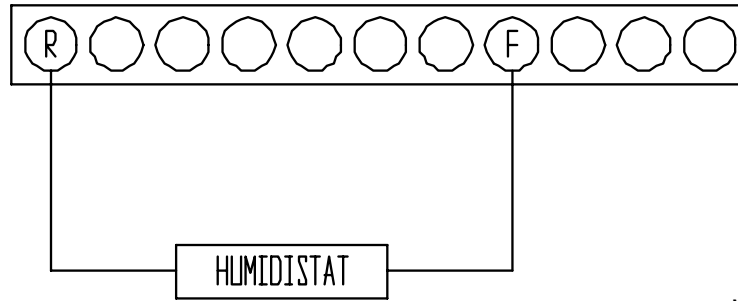

MIS-1642

**FIGURE 20
CIRCUIT DIAGRAMS**

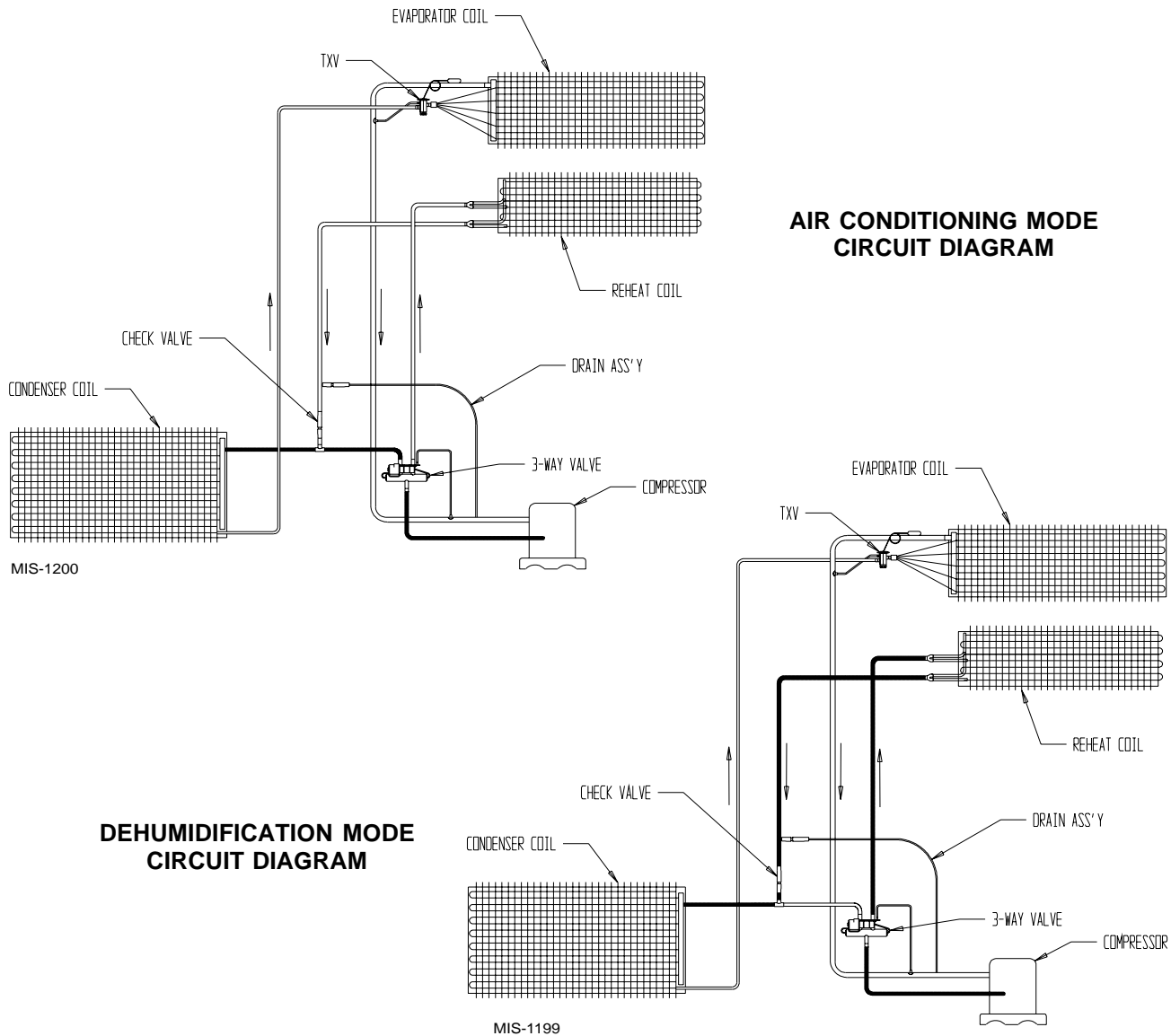

35. FAN BLADE SETTING DIMENSIONS

Shown in Figure 21 is the correct fan blade setting dimension for proper air delivery across the outdoor coil.

**FIGURE 21
FAN BLADE**

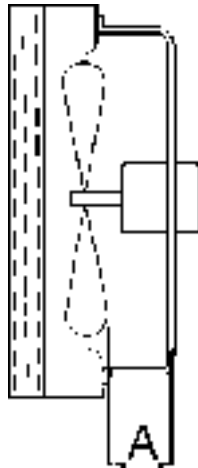

**TABLE 14
FAN BLADE DIMENSION**

| Model | Dimension A |
|-------|-------------|
| WG421 | 1 |
| WG481 | 1 |
| WG601 | 1 |

Any service work requiring removal or adjustment in the fan and/or motor area will require that the dimension below be checked and blade adjusted in or out on the motor shaft accordingly.

36. LOW-NOx BURNER ASSEMBLY "N" SUFFIX MODELS ONLY – U.S. INSTALLATIONS ONLY

NATURAL GAS MODELS ONLY

Model numbers designated with an "N" are designed for low NOx emissions which comply with all California Air Quality Management District regulations for nitrogen oxide emission levels. Refer to Figure 22 for NOx insert information.

**** IMPORTANT ****

For propane (LP) conversions the NOx reduction screen inserts shown below must be removed. This is accomplished by removing the burner box assembly and removing the NOx screens. Reassemble unit properly before firing. Failure to remove the NOx screens can result in improper operation and malfunction of the burner system.

**FIGURE 22
LOW NOx INSERT**

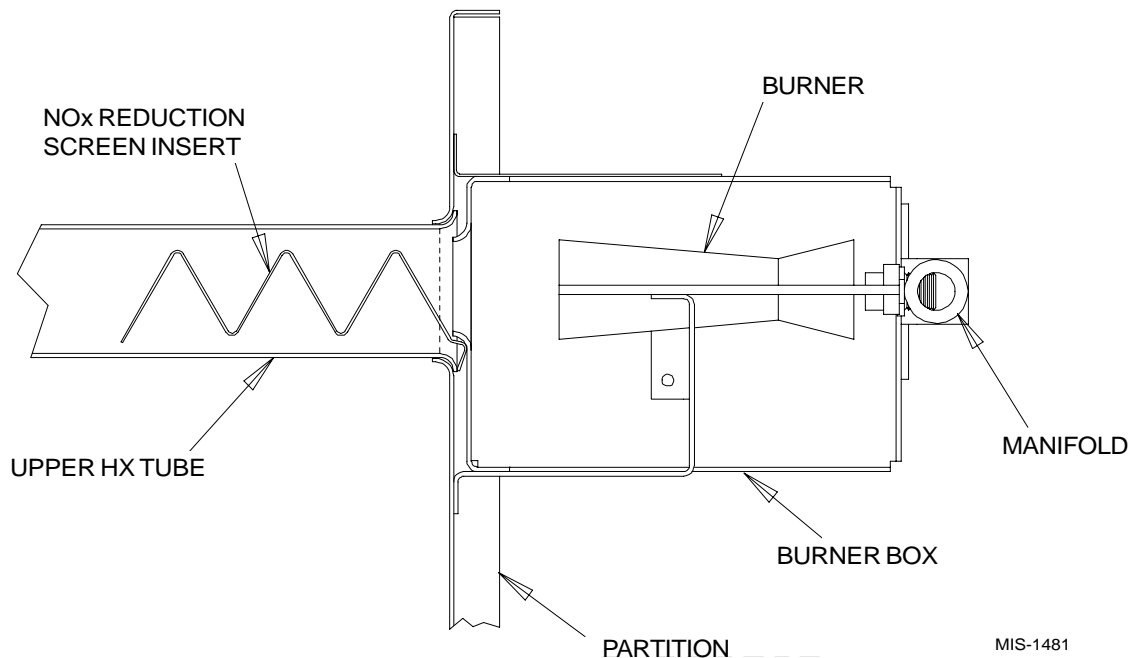

MIS-1481

**TABLE 15
APPLICATION DATA FOR WG421DA**

| Indoor Conditions | | Outdoor Ambient | System Capacity | | | | Pounds Water Lbs/Hr | Airflow CFM | Approx. Supply Air DB/WB | Mode |
|-------------------|-----------|-----------------|-----------------|----------------|---------------|------------|---------------------|--------------|--------------------------|--------------|
| DB/WB | % RH | DB | Total BTU | Sensible BTU | Latent BTU | S/T % | | | | |
| 65/63 | 90 | 65 | 47,000 | 21,200 | 25,800 | 45 | 24.4 | 1300 | 50.8/50.2 | A/C |
| 65/83 | 90 | 65 | 18,000 | (6,400) | 24,400 | 0 | 23 | 1,300 | 69.5/58.2 | Dehum |
| 75/62.5 | 50 | 75 | 43,700 | 33,100 | 10,600 | 76 | 10.06 | 1,300 | 51.8/50.7 | A/C |
| 75/62.5 | 50 | 75 | 12,500 | 4,000 | 8,500 | 32 | 8 | 1,300 | 72.3/59.1 | Dehum |
| 75/65.5 | 60 | 75 | 47,200 | 29,200 | 18,000 | 62 | 17.04 | 1,300 | 54.6/53.6 | A/C |
| 75/65.5 | 60 | 75 | 16,600 | 600 | 16,000 | 3.6 | 15.1 | 1,300 | 74.8/61.3 | Dehum |
| 75/68 | 70 | 75 | 49,700 | 27,000 | 22,700 | 54 | 21.4 | 1,300 | 56.9/55.9 | A/C |
| 75/68 | 70 | 75 | 19,550 | (2,850) | 22,400 | 0 | 21.1 | 1,300 | 77/63.5 | Dehum |
| 80/67 | 50 | 95 | 42,000 | 31,600 | 10,400 | 75 | 9.9 | 1,300 | 58/57 | A/C |
| 80/67 | 50 | 95 | 7,860 | (2,640) | 10,500 | 0 | 9.96 | 1,300 | 81.7/65.5 | Dehum |

**TABLE 16
APPLICATION DATA FOR WG481DA**

| Indoor Conditions | | Outdoor Ambient | System Capacity | | | | Pounds Water Lbs/Hr | Airflow CFM | Approx. Supply Air DB/WB | Mode |
|-------------------|-----------|-----------------|-----------------|----------------|---------------|-----------|---------------------|--------------|--------------------------|--------------|
| DB/WB | % RH | DB | Total BTU | Sensible BTU | Latent BTU | S/T % | | | | |
| 65/63 | 90 | 65 | 51,400 | 22,900 | 28,500 | 44 | 26.9 | 1,550 | 52.5/51.7 | A/C |
| 65/83 | 90 | 65 | 22,300 | (4,500) | 26,800 | 0 | 25.3 | 1,550 | 68.7/58.4 | Dehum |
| 75/62.5 | 50 | 75 | 46,200 | 36,200 | 10,000 | 78 | 9.48 | 1,550 | 52.8/51.7 | A/C |
| 75/62.5 | 50 | 75 | 15,700 | 7,200 | 8,500 | 45 | 8.1 | 1,550 | 71.3/59.2 | Dehum |
| 75/65.5 | 60 | 75 | 51,400 | 34,000 | 17,400 | 66 | 16.4 | 1,550 | 55.7/54.7 | A/C |
| 75/65.5 | 60 | 75 | 19,000 | 3,300 | 15,700 | 17 | 14.9 | 1,550 | 73.8/61.8 | Dehum |
| 75/68 | 70 | 75 | 54,500 | 30,600 | 23,900 | 56 | 22.5 | 1,550 | 58/57 | A/C |
| 75/68 | 70 | 75 | 19,000 | (2,100) | 21,100 | 0 | 19.9 | 1,550 | 76.1/64 | Dehum |
| 80/67 | 50 | 95 | 47,000 | 36,200 | 10,800 | 77 | 10.2 | 1,550 | 59.2/57.6 | A/C |
| 80/67 | 50 | 95 | 7,050 | (1,000) | 8,050 | 0 | 7.6 | 1,550 | 80.7/65.7 | Dehum |

Values shown in () are BTUH of heating available at these conditions.

Latent BTU = Lbs/Hr water * 1060

Sensible BTU = Total - Latent

**TABLE 17
APPLICATION DATA FOR WG601DA**

| Indoor Conditions | | Outdoor Ambient | System Capacity | | | | Pounds Water Lbs/Hr | Airflow CFM | Approx. Supply Air DB/WB | Mode |
|-------------------|-----------|-----------------|-----------------|----------------|---------------|-------------|---------------------|--------------|--------------------------|--------------|
| DB/WB | % RH | DB | Total BTU | Sensible BTU | Latent BTU | S/T % | | | | |
| 65/63 | 90 | 65 | 64,000 | 28,600 | 35,400 | 45 | 33.4 | 1,650 | 50/49.4 | A/C |
| 65/83 | 90 | 65 | 26,700 | (8,300) | 35,000 | 0 | 33.1 | 1,650 | 70.2/57.8 | Dehum |
| 75/62.5 | 50 | 75 | 61,400 | 44,800 | 16,600 | 73 | 15.7 | 1,650 | 50.6/49.4 | A/C |
| 75/62.5 | 50 | 75 | 20,800 | 4,900 | 15,900 | 23.5 | 15 | 1,650 | 72.6/58.5 | Dehum |
| 75/65.5 | 60 | 75 | 65,200 | 39,900 | 25,300 | 61 | 23.9 | 1,650 | 53.5/52.4 | A/C |
| 75/65.5 | 60 | 75 | 23,900 | (500) | 24,400 | 0 | 23 | 1,650 | 75/61.2 | Dehum |
| 75/68 | 70 | 75 | 68,500 | 36,100 | 32,400 | 53 | 30.6 | 1650 | 56.9/54.9 | A/C |
| 75/68 | 70 | 75 | 27,300 | (4,000) | 31,300 | 0 | 29.5 | 1,650 | 77.7/63.3 | Dehum |
| 80/67 | 50 | 95 | 60,000 | 42,200 | 17,800 | 70 | 16.8 | 1,650 | 56.6/55.2 | A/C |
| 80/67 | 50 | 95 | 11,300 | (4,700) | 16,000 | 0 | 15.1 | 1,650 | 81.5/64.6 | Dehum |

VALUES SHOWN IN () ARE BTUH OF HEATING AVAILABLE AT THESE CONDITIONS.
 LATENT BTU = LBS/HR WATER * 1060
 SENSIBLE BTU = TOTAL - LATENT

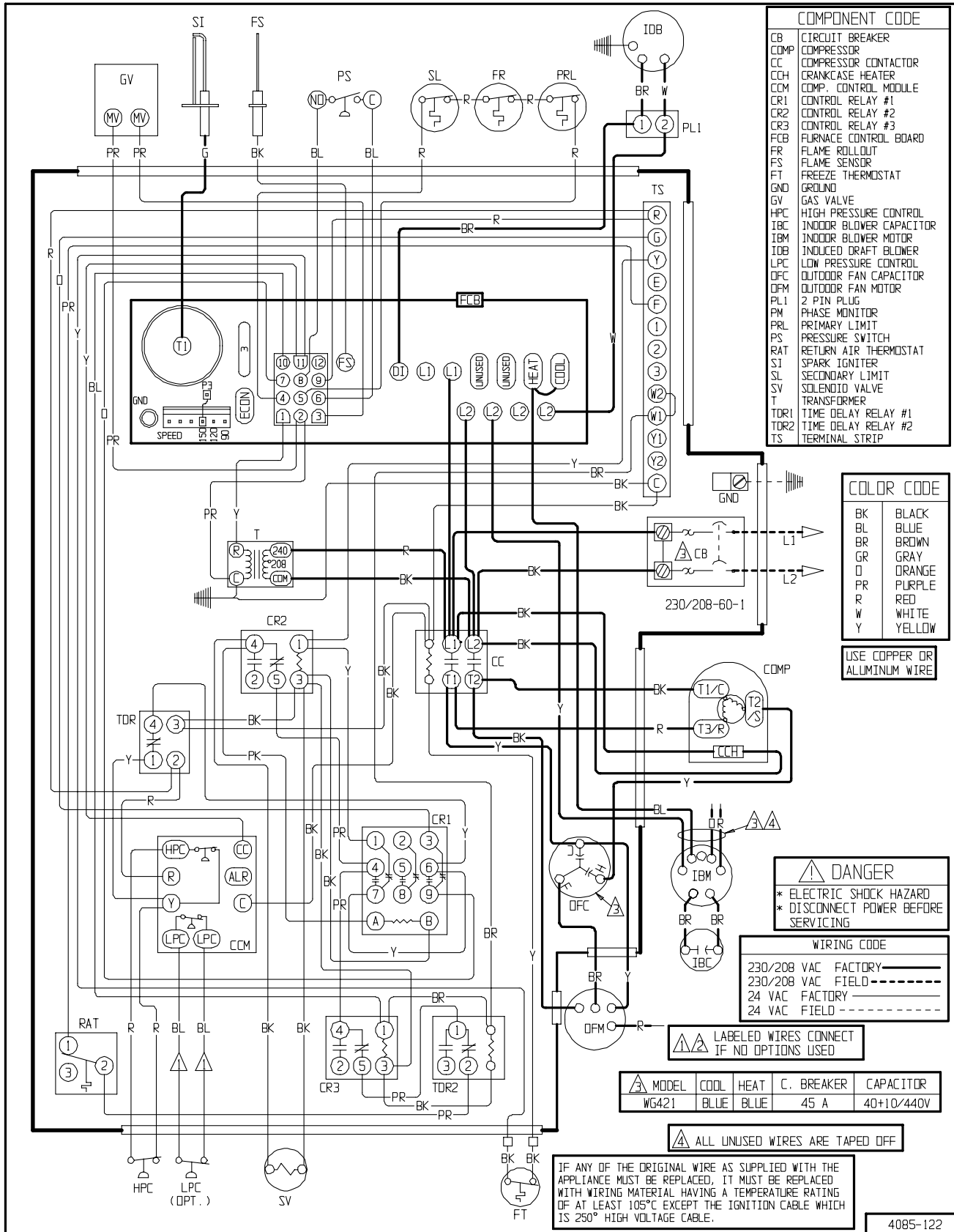

COMPONENT CODE

| | |
|------|-------------------------|
| CB | CIRCUIT BREAKER |
| COMP | COMPRESSOR |
| CC | COMPRESSOR CONTACTOR |
| CH | CRANKCASE HEATER |
| CCM | COMP. CONTROL MODULE |
| CR1 | CONTROL RELAY #1 |
| CR2 | CONTROL RELAY #2 |
| CR3 | CONTROL RELAY #3 |
| FCB | FURNACE CONTROL BOARD |
| FR | FLAME ROLLOUT |
| FS | FLAME SENSOR |
| FT | FREEZE THERMOSTAT |
| GND | GROUND |
| GV | GAS VALVE |
| HPC | HIGH PRESSURE CONTROL |
| IBC | INDOOR BLOWER CAPACITOR |
| IBM | INDOOR BLOWER MOTOR |
| IDB | INDUCED DRAFT BLOWER |
| LPC | LOW PRESSURE CONTROL |
| OFM | OUTDOOR FAN MOTOR |
| PL1 | 2 PIN PLUG |
| PM | PHASE MONITOR |
| PRL | PRIMARY LIMIT |
| PS | PRESSURE SWITCH |
| RAT | RETURN AIR THERMOSTAT |
| SI | SPARK IGNITER |
| SL | SECONDARY LIMIT |
| SV | SOLENOID VALVE |
| T | TRANSFORMER |
| TDR1 | TIME DELAY RELAY #1 |
| TDR2 | TIME DELAY RELAY #2 |
| TS | TERMINAL STRIP |

COLOR CODE

| | |
|----|--------|
| BK | BLACK |
| BL | BLUE |
| BR | BROWN |
| GR | GRAY |
| O | ORANGE |
| PR | PURPLE |
| R | RED |
| W | WHITE |
| Y | YELLOW |

USE COPPER OR ALUMINUM WIRE

⚠ DANGER
 * ELECTRIC SHOCK HAZARD
 * DISCONNECT POWER BEFORE SERVICING

WIRING CODE

| | |
|---------------------|-----------|
| 230/208 VAC FACTORY | ————— |
| 230/208 VAC FIELD | - - - - - |
| 24 VAC FACTORY | ————— |
| 24 VAC FIELD | - - - - - |

⚠ Labeled wires connect if no options used

| MODEL | COOL | HEAT | C. BREAKER | CAPACITOR |
|-------|------|------|------------|------------|
| WG421 | BLUE | BLUE | 45 A | 40+10/440V |

⚠ ALL UNUSED WIRES ARE TAPED OFF

IF ANY OF THE ORIGINAL WIRE AS SUPPLIED WITH THE APPLIANCE MUST BE REPLACED, IT MUST BE REPLACED WITH WIRING MATERIAL HAVING A TEMPERATURE RATING OF AT LEAST 105°C EXCEPT THE IGNITION CABLE WHICH IS 250° HIGH VOLTAGE CABLE.

4085-122

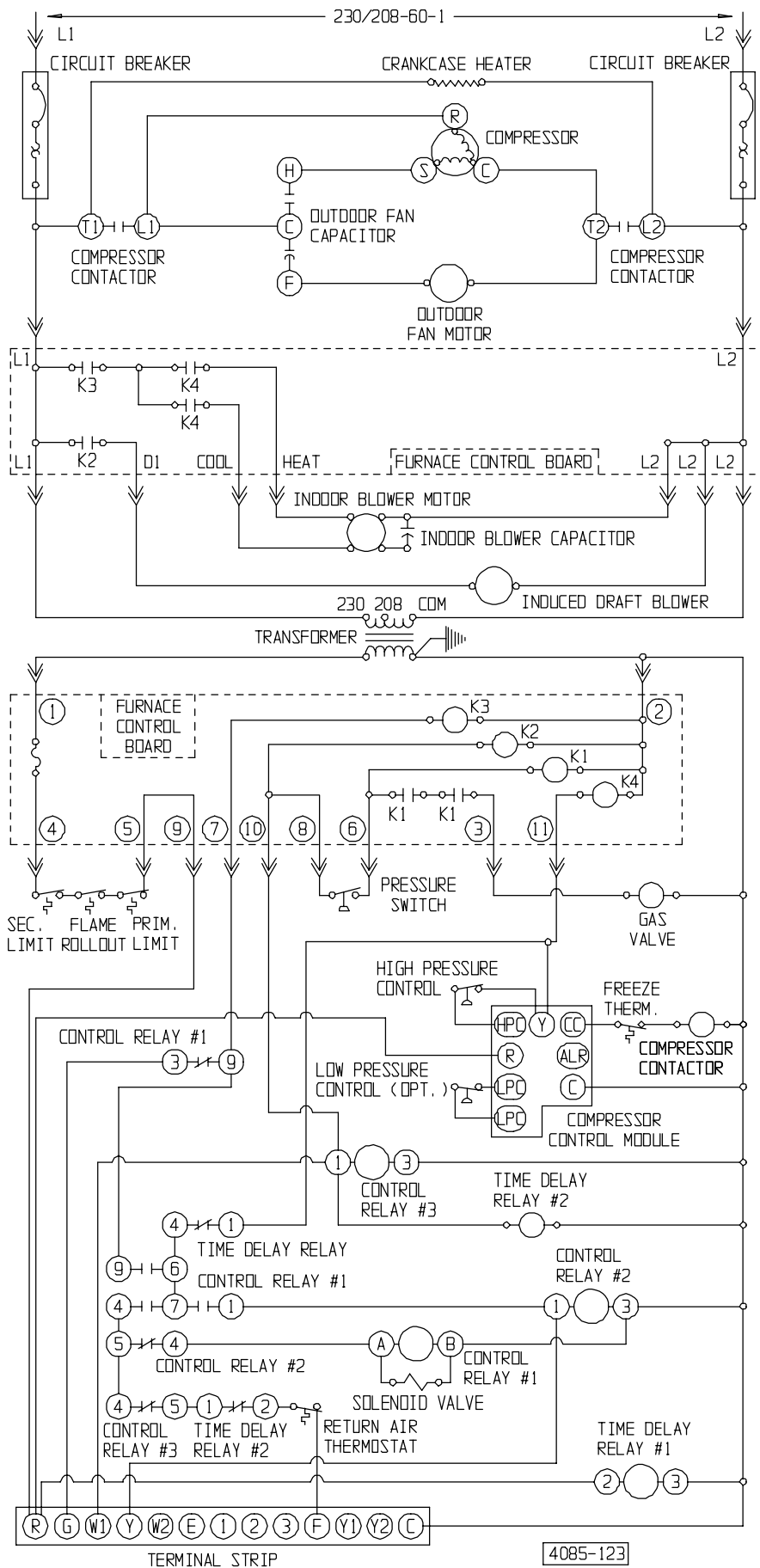

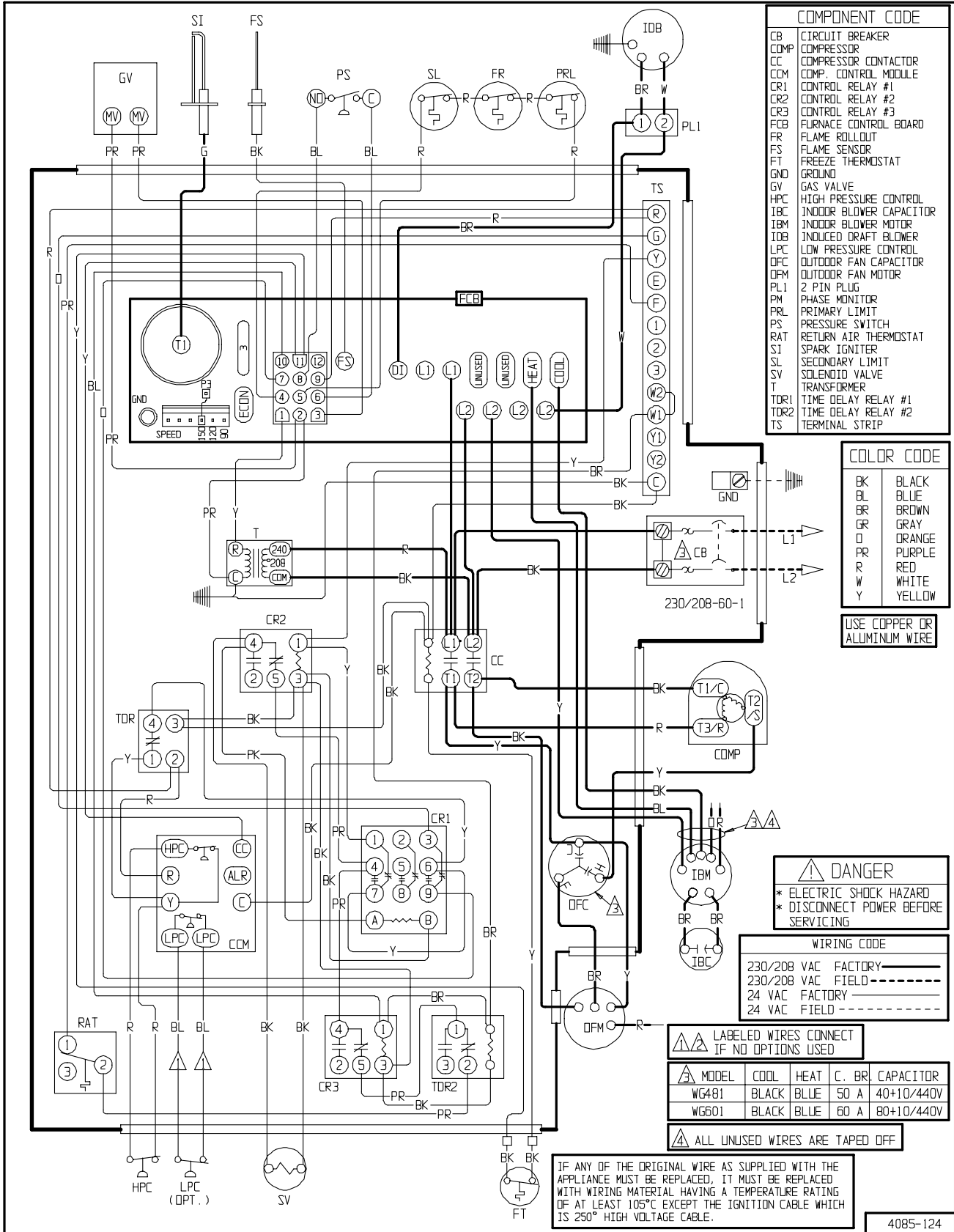

COMPONENT CODE

| | |
|------|-------------------------|
| CB | CIRCUIT BREAKER |
| COMP | COMPRESSOR |
| CC | COMPRESSOR CONTACTOR |
| CCM | COMP. CONTROL MODULE |
| CR1 | CONTROL RELAY #1 |
| CR2 | CONTROL RELAY #2 |
| CR3 | CONTROL RELAY #3 |
| FCB | FURNACE CONTROL BOARD |
| FR | FLAME ROLLOUT |
| FS | FLAME SENSOR |
| FT | FREEZE THERMOSTAT |
| GND | GROUND |
| GV | GAS VALVE |
| HPC | HIGH PRESSURE CONTROL |
| IBC | INDOOR BLOWER CAPACITOR |
| IBM | INDOOR BLOWER MOTOR |
| IDB | INDUCED DRAFT BLOWER |
| LPC | LOW PRESSURE CONTROL |
| OFM | OUTDOOR FAN CAPACITOR |
| OFM | OUTDOOR FAN MOTOR |
| PL1 | 2 PIN PLUG |
| PM | PHASE MONITOR |
| PRL | PRIMARY LIMIT |
| PS | PRESSURE SWITCH |
| RAT | RETURN AIR THERMOSTAT |
| SI | SPARK IGNITER |
| SL | SECONDARY LIMIT |
| SV | SOLENOID VALVE |
| T | TRANSFORMER |
| TDR1 | TIME DELAY RELAY #1 |
| TDR2 | TIME DELAY RELAY #2 |
| TS | TERMINAL STRIP |

COLOR CODE

| | |
|----|--------|
| BK | BLACK |
| BL | BLUE |
| BR | BROWN |
| GR | GRAY |
| O | ORANGE |
| PR | PURPLE |
| R | RED |
| W | WHITE |
| Y | YELLOW |

USE COPPER OR ALUMINUM WIRE

DANGER
 * ELECTRIC SHOCK HAZARD
 * DISCONNECT POWER BEFORE SERVICING

WIRING CODE

| | | |
|-------------|---------|-----------|
| 230/208 VAC | FACTORY | ————— |
| 230/208 VAC | FIELD | - - - - - |
| 24 VAC | FACTORY | ————— |
| 24 VAC | FIELD | - - - - - |

LABELLED WIRES CONNECT IF NO OPTIONS USED

| MODEL | COOL | HEAT | C. BR. | CAPACITOR |
|-------|-------|------|--------|------------|
| WG481 | BLACK | BLUE | 50 A | 40+10/440V |
| WG601 | BLACK | BLUE | 60 A | 80+10/440V |

ALL UNUSED WIRES ARE TAPED OFF

IF ANY OF THE ORIGINAL WIRE AS SUPPLIED WITH THE APPLIANCE MUST BE REPLACED, IT MUST BE REPLACED WITH WIRING MATERIAL HAVING A TEMPERATURE RATING OF AT LEAST 105°C EXCEPT THE IGNITION CABLE WHICH IS 250° HIGH VOLTAGE CABLE.

4085-124

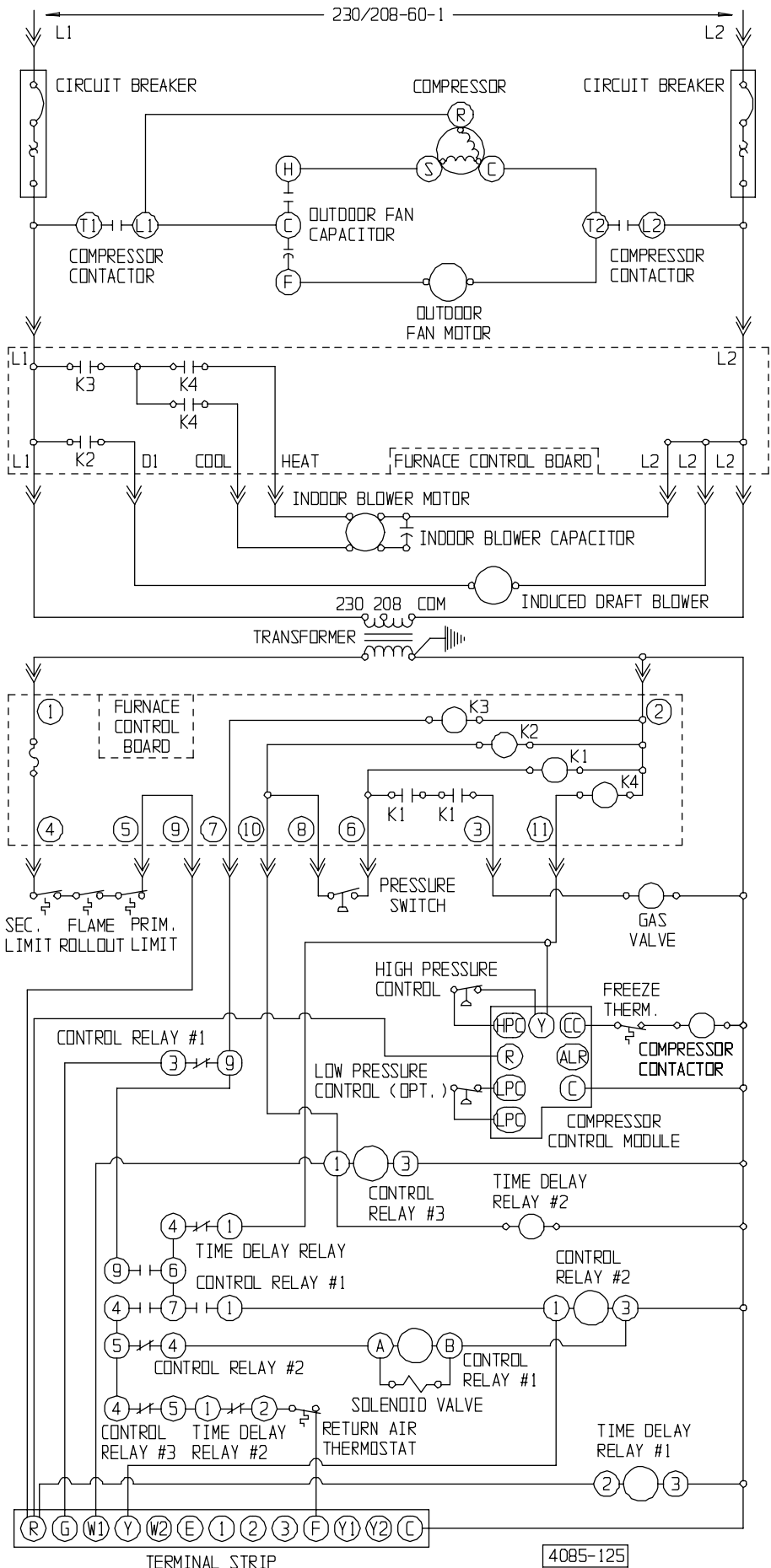

230/208-60-1

L1 L2

CIRCUIT BREAKER COMPRESSOR CIRCUIT BREAKER
 T1 L1 T2 L2
 COMPRESSOR CONTACTOR OUTDOOR FAN CAPACITOR COMPRESSOR CONTACTOR
 H S C
 F OUTDOOR FAN MOTOR

L1 L2
 K3 K4 K4
 K2 D1 COOL HEAT FURNACE CONTROL BOARD L2 L2 L2
 INDOOR BLOWER MOTOR INDOOR BLOWER CAPACITOR
 230 208 COM INDUCED DRAFT BLOWER
 TRANSFORMER

FURNACE CONTROL BOARD
 1 2
 4 5 9 7 10 8 6 3 11
 SEC. FLAME PRIM. LIMIT ROLLOUT LIMIT
 PRESSURE SWITCH
 GAS VALVE
 HIGH PRESSURE CONTROL
 FREEZE THERM. COMPRESSOR CONTACTOR
 LOW PRESSURE CONTROL (OPT.)
 HPC Y CC
 R ALR
 LPC C
 LPC
 COMPRESSOR CONTROL MODULE
 CONTROL RELAY #1
 3 9
 TIME DELAY RELAY #2
 CONTROL RELAY #3
 TIME DELAY RELAY
 9 6
 CONTROL RELAY #1
 4 7 1
 CONTROL RELAY #2
 5 4
 CONTROL RELAY #1
 4 5 1 2
 SOLENOID VALVE
 RETURN AIR THERMOSTAT
 TIME DELAY RELAY #1
 2 3

TERMINAL STRIP
 R G W1 Y W2 E I 2 3 F Y1 Y2 C

4085-125

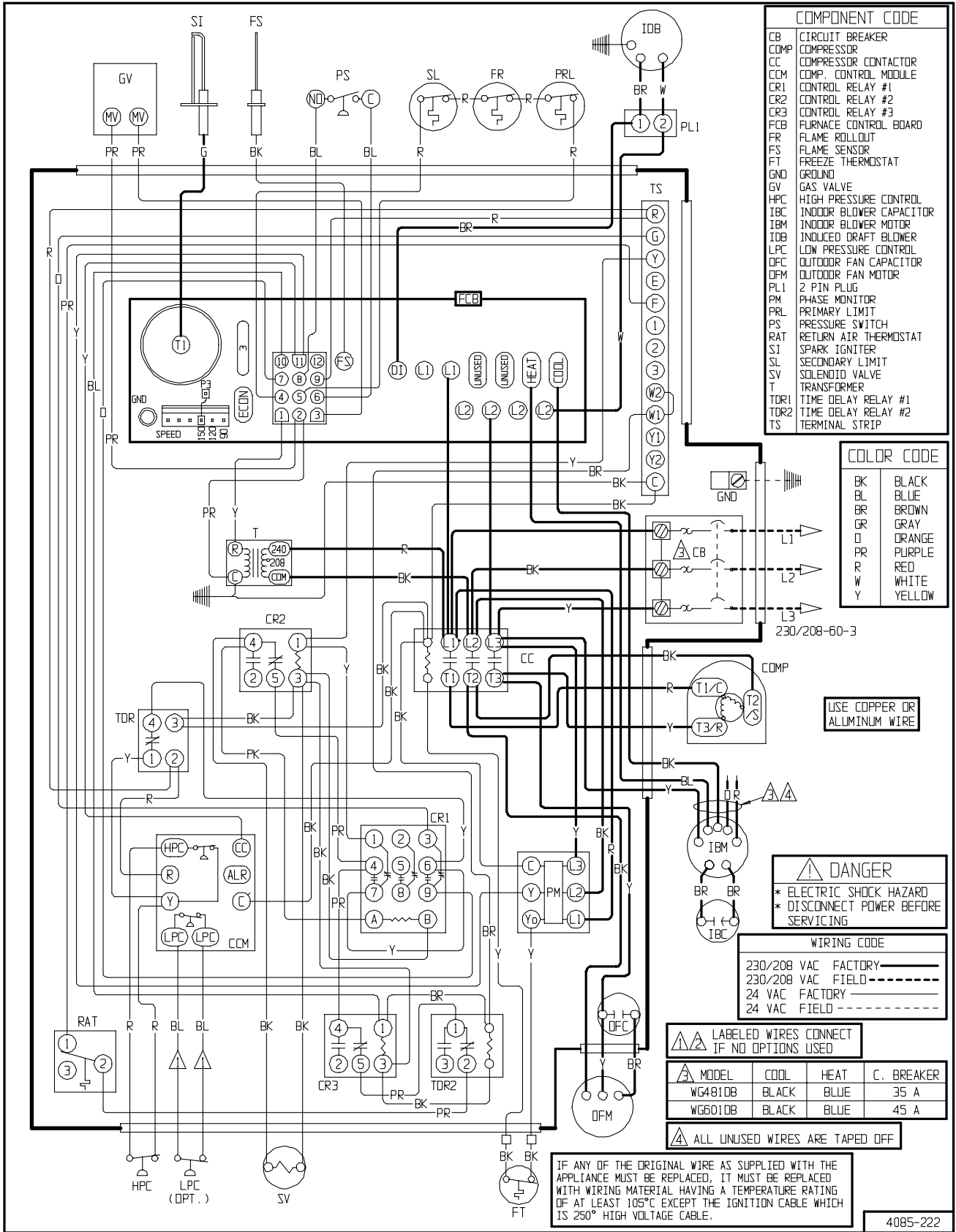

COMPONENT CODE

| | |
|------|-------------------------|
| CB | CIRCUIT BREAKER |
| COMP | COMPRESSOR |
| CCM | COMP. CONTROL MODULE |
| CR1 | CONTROL RELAY #1 |
| CR2 | CONTROL RELAY #2 |
| CR3 | CONTROL RELAY #3 |
| FCB | FURNACE CONTROL BOARD |
| FR | FLAME ROLLOUT |
| FS | FLAME SENSOR |
| FT | FREEZE THERMOSTAT |
| GND | GROUND |
| GV | GAS VALVE |
| HPC | HIGH PRESSURE CONTROL |
| IBC | INDOOR BLOWER CAPACITOR |
| IBM | INDOOR BLOWER MOTOR |
| IOB | INDUCED DRAFT BLOWER |
| LPC | LOW PRESSURE CONTROL |
| OFC | OUTDOOR FAN CAPACITOR |
| OFM | OUTDOOR FAN MOTOR |
| PL1 | 2 PIN PLUG |
| PM | PHASE MONITOR |
| PRL | PRIMARY LIMIT |
| PS | PRESSURE SWITCH |
| RAT | RETURN AIR THERMOSTAT |
| SI | SPARK IGNITER |
| SL | SECONDARY LIMIT |
| SV | SOLENOID VALVE |
| T | TRANSFORMER |
| TDR1 | TIME DELAY RELAY #1 |
| TDR2 | TIME DELAY RELAY #2 |
| TS | TERMINAL STRIP |

COLOR CODE

| | |
|----|--------|
| BK | BLACK |
| BL | BLUE |
| BR | BROWN |
| GR | GRAY |
| O | ORANGE |
| PR | PURPLE |
| R | RED |
| W | WHITE |
| Y | YELLOW |

USE COPPER OR ALUMINUM WIRE

⚠ DANGER
 * ELECTRIC SHOCK HAZARD
 * DISCONNECT POWER BEFORE SERVICING

WIRING CODE

| | | |
|-------------|---------|-------|
| 230/208 VAC | FACTORY | _____ |
| 230/208 VAC | FIELD | ----- |
| 24 VAC | FACTORY | _____ |
| 24 VAC | FIELD | ----- |

⚠ Labeled wires connect if no options used

| MODEL | COOL | HEAT | C. BREAKER |
|---------|-------|------|------------|
| WG4810B | BLACK | BLUE | 35 A |
| WG6010B | BLACK | BLUE | 45 A |

⚠ ALL UNUSED WIRES ARE TAPED OFF

IF ANY OF THE ORIGINAL WIRE AS SUPPLIED WITH THE APPLIANCE MUST BE REPLACED, IT MUST BE REPLACED WITH WIRING MATERIAL HAVING A TEMPERATURE RATING OF AT LEAST 105°C EXCEPT THE IGNITION CABLE WHICH IS 250° HIGH VOLTAGE CABLE.

4085-222

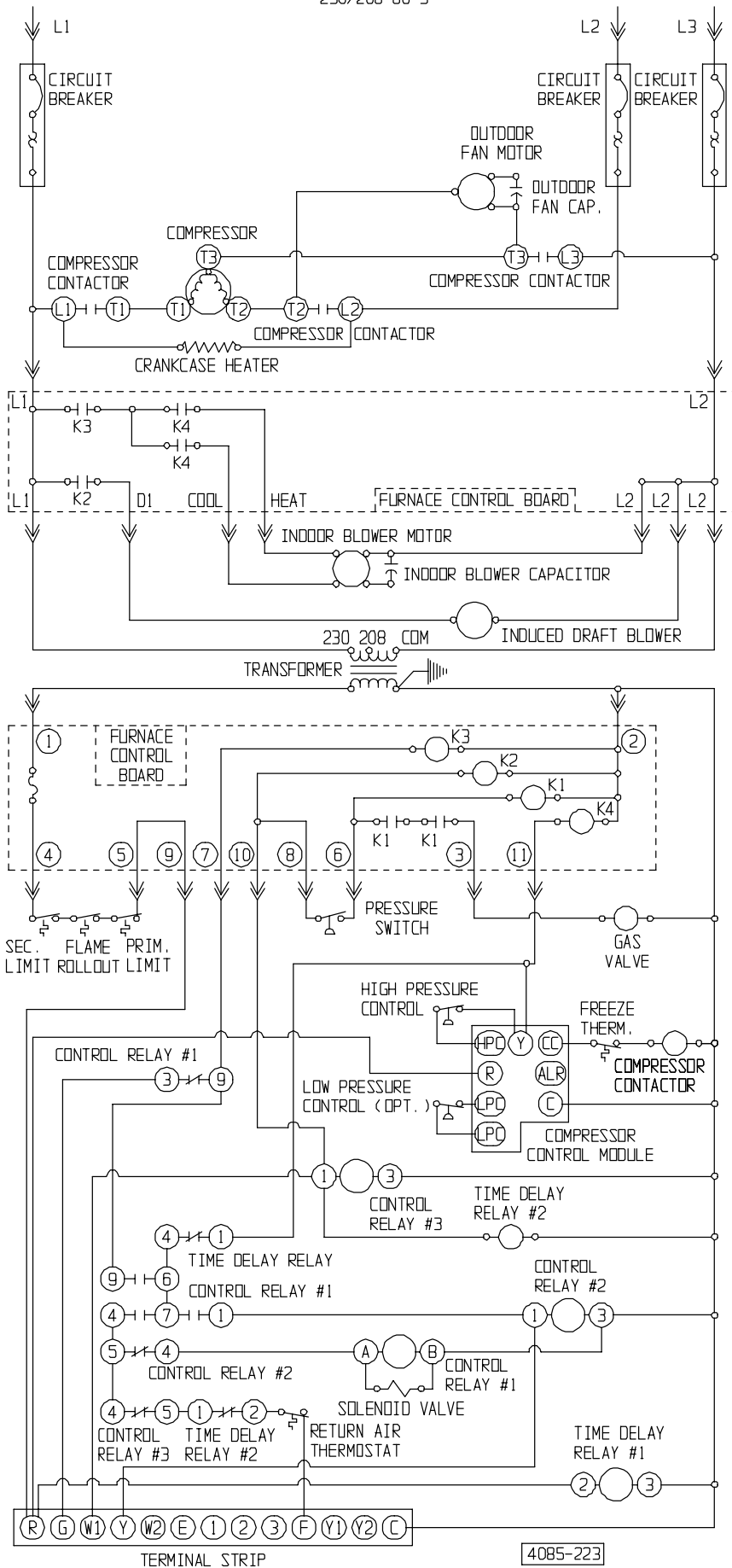

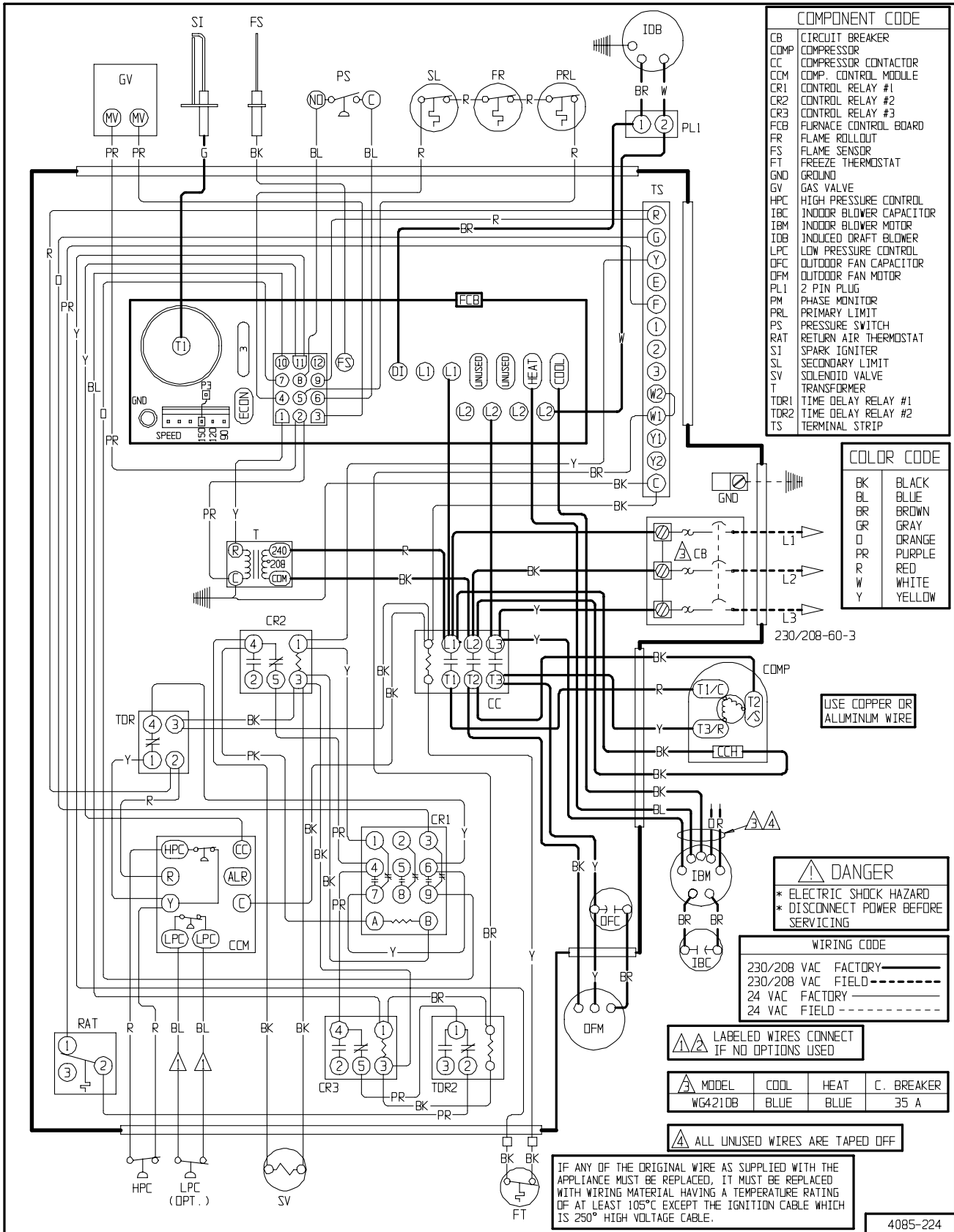

COMPONENT CODE

| | |
|------|-------------------------|
| CB | CIRCUIT BREAKER |
| COMP | COMPRESSOR |
| CC | COMPRESSOR CONTACTOR |
| CCM | COMP. CONTROL MODULE |
| CR1 | CONTROL RELAY #1 |
| CR2 | CONTROL RELAY #2 |
| CR3 | CONTROL RELAY #3 |
| FCB | FURNACE CONTROL BOARD |
| FR | FLAME ROLLOUT |
| FS | FLAME SENSOR |
| FT | FREEZE THERMOSTAT |
| GND | GROUND |
| GV | GAS VALVE |
| HPC | HIGH PRESSURE CONTROL |
| IBC | INDOOR BLOWER CAPACITOR |
| IBM | INDOOR BLOWER MOTOR |
| IDB | INDUCED DRAFT BLOWER |
| LPC | LOW PRESSURE CONTROL |
| DFC | OUTDOOR FAN CAPACITOR |
| OFM | OUTDOOR FAN MOTOR |
| PL1 | 2 PIN PLUG |
| PM | PHASE MONITOR |
| PRL | PRIMARY LIMIT |
| PS | PRESSURE SWITCH |
| RAT | RETURN AIR THERMOSTAT |
| SI | SPARK IGNITER |
| SL | SECONDARY LIMIT |
| SV | SOLENOID VALVE |
| T | TRANSFORMER |
| TDR1 | TIME DELAY RELAY #1 |
| TDR2 | TIME DELAY RELAY #2 |
| TS | TERMINAL STRIP |

COLOR CODE

| | |
|----|--------|
| BK | BLACK |
| BL | BLUE |
| BR | BROWN |
| GR | GRAY |
| D | DRANGE |
| PR | PURPLE |
| R | RED |
| W | WHITE |
| Y | YELLOW |

USE COPPER OR ALUMINUM WIRE

DANGER
 * ELECTRIC SHOCK HAZARD
 * DISCONNECT POWER BEFORE SERVICING

WIRING CODE

| | | |
|-------------|---------|-----------|
| 230/208 VAC | FACTORY | ————— |
| 230/208 VAC | FIELD | - - - - - |
| 24 VAC | FACTORY | ————— |
| 24 VAC | FIELD | - - - - - |

LABELLED WIRES CONNECT IF NO OPTIONS USED

| | | | |
|---------|------|------|------------|
| MODEL | COOL | HEAT | C. BREAKER |
| WG421DB | BLUE | BLUE | 35 A |

ALL UNUSED WIRES ARE TAPED OFF

IF ANY OF THE ORIGINAL WIRE AS SUPPLIED WITH THE APPLIANCE MUST BE REPLACED, IT MUST BE REPLACED WITH WIRING MATERIAL HAVING A TEMPERATURE RATING OF AT LEAST 105°C EXCEPT THE IGNITION CABLE WHICH IS 250° HIGH VOLTAGE CABLE.

4085-224

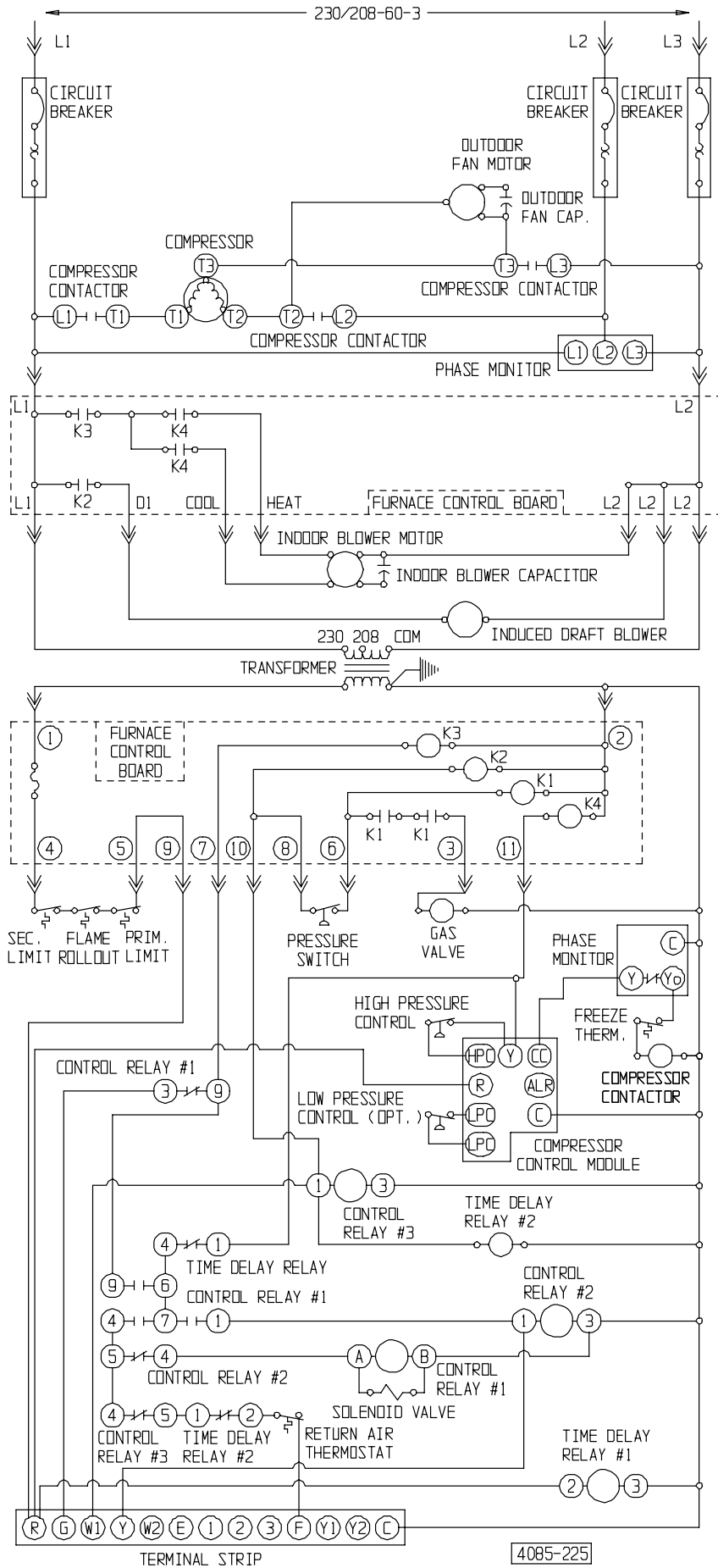

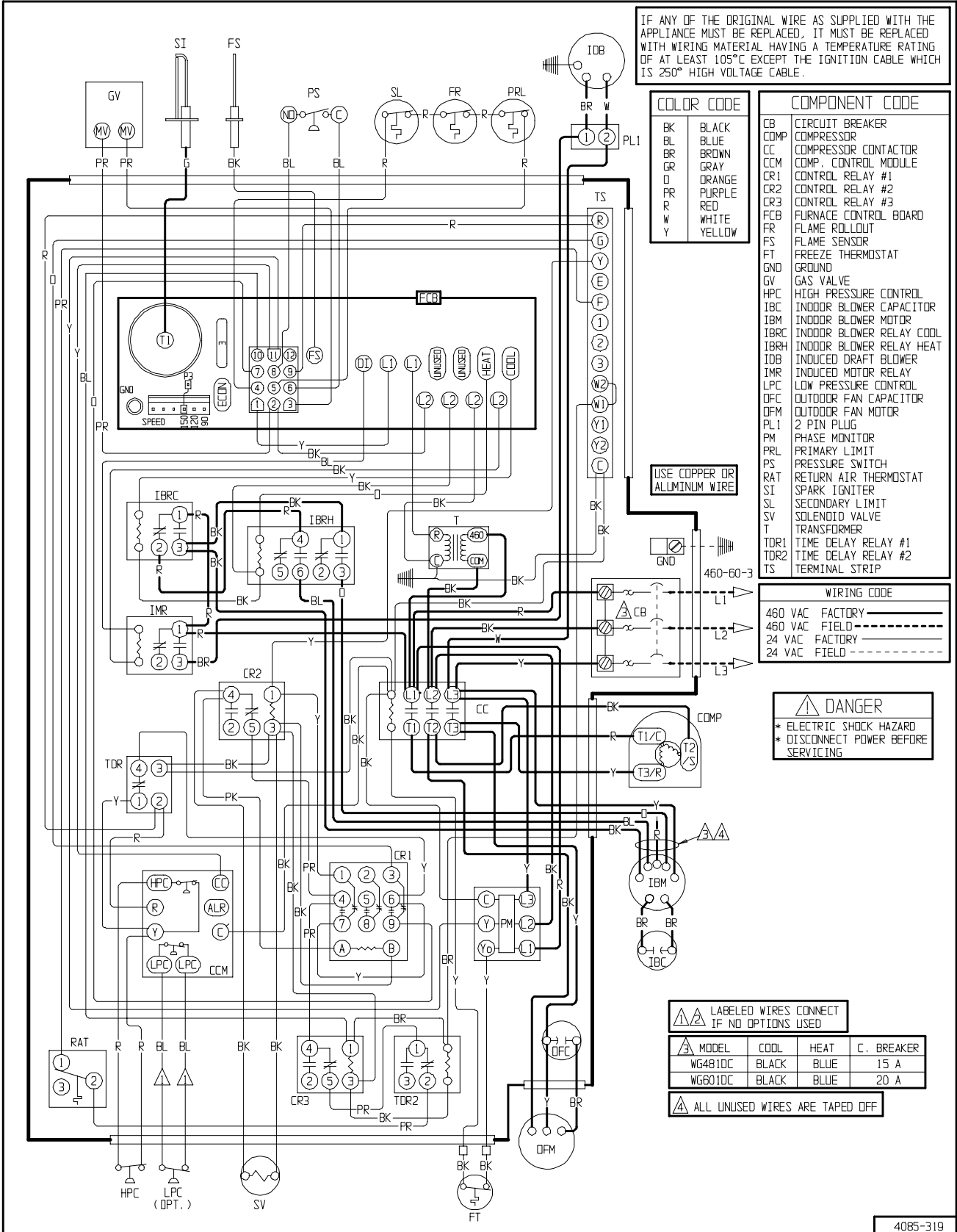

IF ANY OF THE ORIGINAL WIRE AS SUPPLIED WITH THE APPLIANCE MUST BE REPLACED, IT MUST BE REPLACED WITH WIRING MATERIAL HAVING A TEMPERATURE RATING OF AT LEAST 105°C EXCEPT THE IGNITION CABLE WHICH IS 250° HIGH VOLTAGE CABLE.

COLOR CODE

| | |
|----|--------|
| BK | BLACK |
| BL | BLUE |
| BR | BROWN |
| GR | GRAY |
| D | DRANGE |
| PR | PURPLE |
| R | RED |
| W | WHITE |
| Y | YELLOW |

COMPONENT CODE

| | |
|------|--------------------------|
| CB | CIRCUIT BREAKER |
| COMP | COMPRESSOR |
| CC | COMPRESSOR CONTACTOR |
| CCM | COMP. CONTROL MODULE |
| CR1 | CONTROL RELAY #1 |
| CR2 | CONTROL RELAY #2 |
| CR3 | CONTROL RELAY #3 |
| FCB | FURNACE CONTROL BOARD |
| FR | FLAME ROLLOUT |
| FS | FLAME SENSOR |
| FT | FREEZE THERMOSTAT |
| GND | GROUND |
| GV | GAS VALVE |
| HPC | HIGH PRESSURE CONTROL |
| IBC | INDOOR BLOWER CAPACITOR |
| IBM | INDOOR BLOWER MOTOR |
| IBRC | INDOOR BLOWER RELAY COOL |
| IBRH | INDOOR BLOWER RELAY HEAT |
| IDB | INDUCED DRAFT BLOWER |
| IMR | INDUCED MOTOR RELAY |
| LPC | LOW PRESSURE CONTROL |
| OFC | OUTDOOR FAN CAPACITOR |
| OFM | OUTDOOR FAN MOTOR |
| PL1 | 2 PIN PLUG |
| PM | PHASE MONITOR |
| PRL | PRIMARY LIMIT |
| PS | PRESSURE SWITCH |
| RAT | RETURN AIR THERMOSTAT |
| SI | SPARK IGNITER |
| SL | SECONDARY LIMIT |
| SV | SOLENOID VALVE |
| T | TRANSFORMER |
| TDR1 | TIME DELAY RELAY #1 |
| TDR2 | TIME DELAY RELAY #2 |
| TS | TERMINAL STRIP |

USE COPPER OR ALUMINUM WIRE

WIRING CODE

| | | |
|---------|---------|-------|
| 460 VAC | FACTORY | _____ |
| 460 VAC | FIELD | ----- |
| 24 VAC | FACTORY | _____ |
| 24 VAC | FIELD | ----- |

⚠ DANGER
 * ELECTRIC SHOCK HAZARD
 * DISCONNECT POWER BEFORE SERVICING

⚠ Labeled wires connect if no options used

| MODEL | COOL | HEAT | C. BREAKER |
|---------|-------|------|------------|
| WG481DC | BLACK | BLUE | 15 A |
| WG601DC | BLACK | BLUE | 20 A |

⚠ ALL UNUSED WIRES ARE TAPED OFF

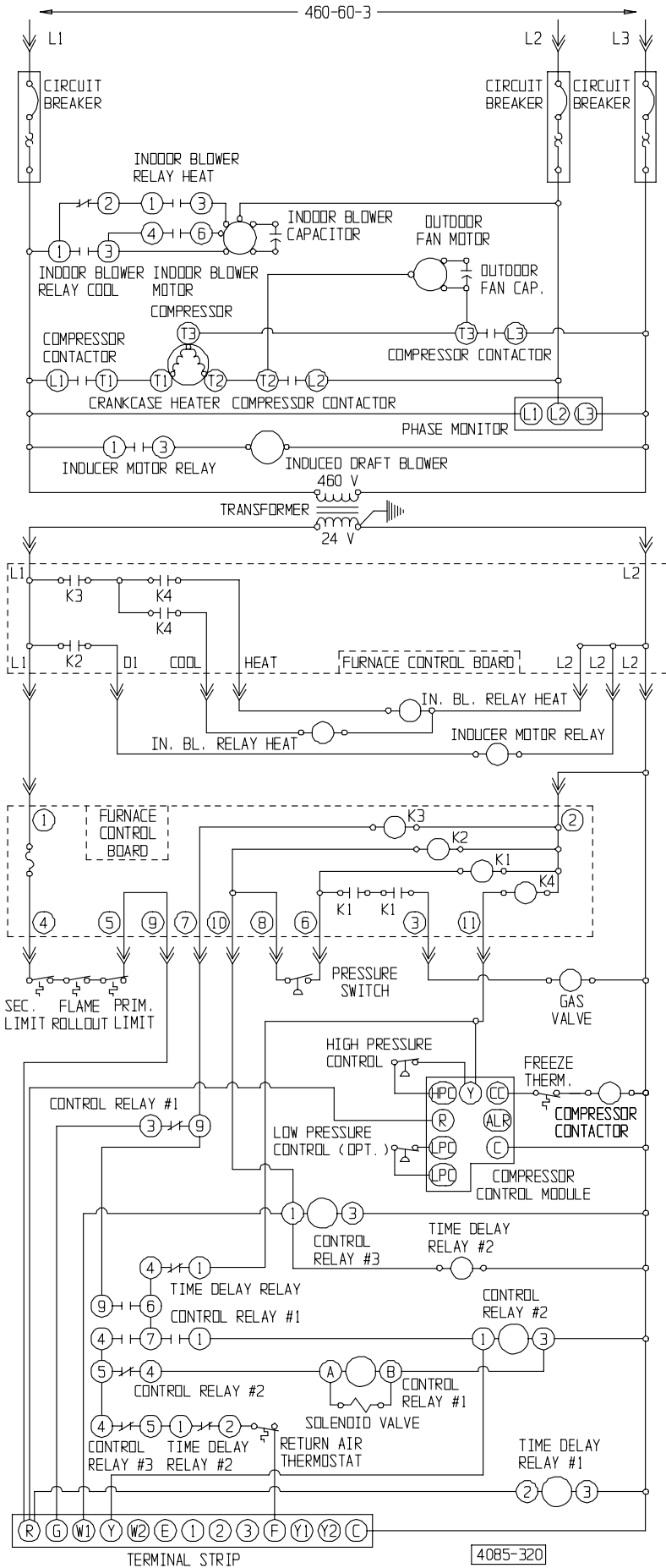

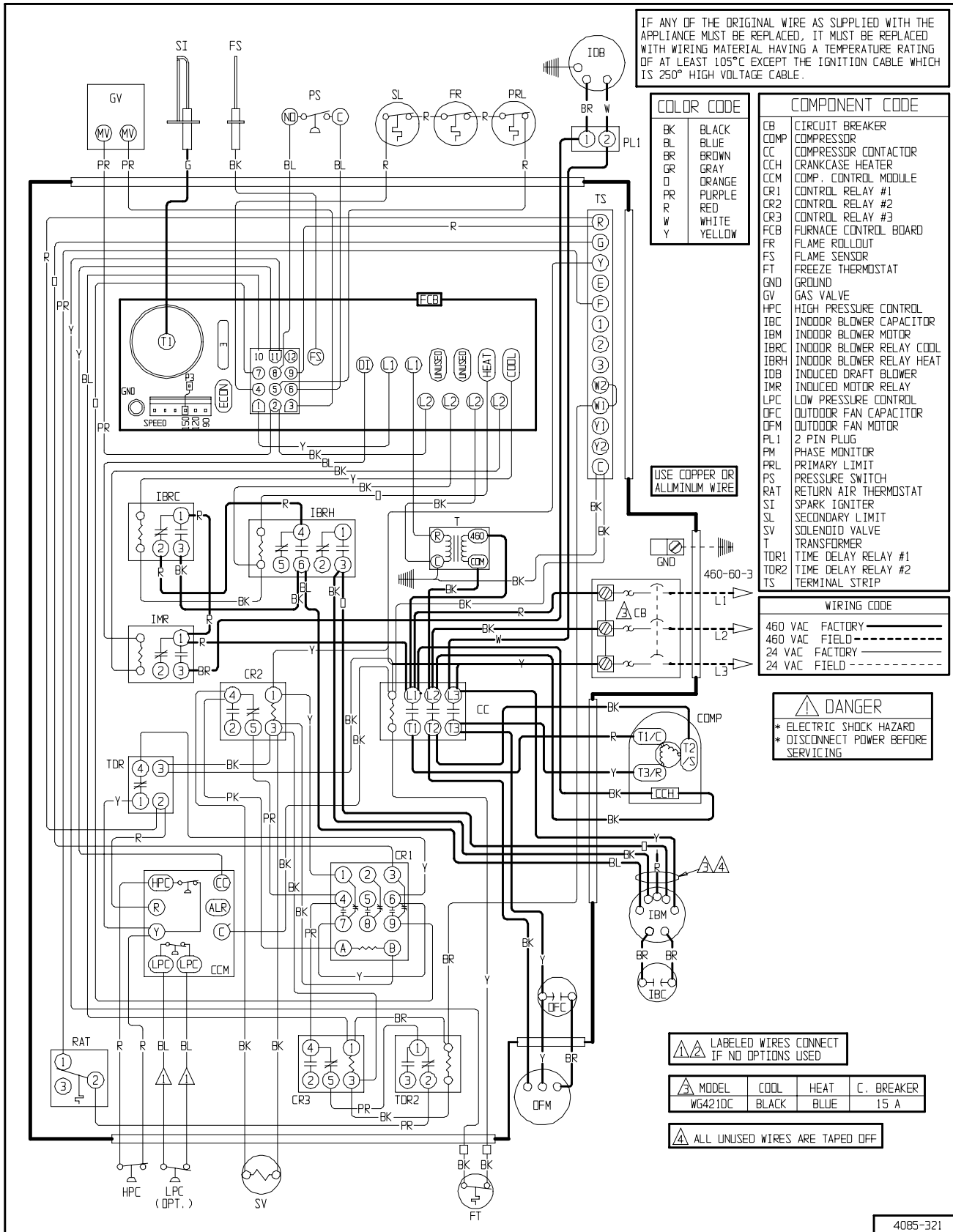

IF ANY OF THE ORIGINAL WIRE AS SUPPLIED WITH THE APPLIANCE MUST BE REPLACED, IT MUST BE REPLACED WITH WIRING MATERIAL HAVING A TEMPERATURE RATING OF AT LEAST 105°C EXCEPT THE IGNITION CABLE WHICH IS 250° HIGH VOLTAGE CABLE.

| COLOR CODE | |
|------------|--------|
| BK | BLACK |
| BL | BLUE |
| BR | BROWN |
| GR | GRAY |
| O | ORANGE |
| PR | PURPLE |
| R | RED |
| W | WHITE |
| Y | YELLOW |

| COMPONENT CODE | |
|----------------|--------------------------|
| CB | CIRCUIT BREAKER |
| COMP | COMPRESSOR |
| CC | COMPRESSOR CONTACTOR |
| CCH | CRANKCASE HEATER |
| CCM | COMP. CONTROL MODULE |
| CR1 | CONTROL RELAY #1 |
| CR2 | CONTROL RELAY #2 |
| CR3 | CONTROL RELAY #3 |
| FCB | FURNACE CONTROL BOARD |
| FR | FLAME ROLLOUT |
| FS | FLAME SENSOR |
| FT | FREEZE THERMOSTAT |
| GND | GROUND |
| GV | GAS VALVE |
| HPC | HIGH PRESSURE CONTROL |
| IBC | INDOOR BLOWER CAPACITOR |
| IBM | INDOOR BLOWER MOTOR |
| IBRC | INDOOR BLOWER RELAY COOL |
| IBRH | INDOOR BLOWER RELAY HEAT |
| IDB | INDUCED DRAFT BLOWER |
| IMR | INDUCED MOTOR RELAY |
| LPC | LOW PRESSURE CONTROL |
| OFC | OUTDOOR FAN CAPACITOR |
| OFM | OUTDOOR FAN MOTOR |
| PL1 | 2 PIN PLUG |
| PM | PHASE MONITOR |
| PRL | PRIMARY LIMIT |
| PS | PRESSURE SWITCH |
| RAT | RETURN AIR THERMOSTAT |
| SI | SPARK IGNITER |
| SL | SECONDARY LIMIT |
| SV | SOLENOID VALVE |
| T | TRANSFORMER |
| TDR1 | TIME DELAY RELAY #1 |
| TDR2 | TIME DELAY RELAY #2 |
| TS | TERMINAL STRIP |

USE COPPER OR ALUMINUM WIRE

| WIRING CODE | |
|-------------|---------|
| 460 VAC | FACTORY |
| 460 VAC | FIELD |
| 24 VAC | FACTORY |
| 24 VAC | FIELD |

⚠ DANGER
 * ELECTRIC SHOCK HAZARD
 * DISCONNECT POWER BEFORE SERVICING

⚠ LABELED WIRES CONNECT IF NO OPTIONS USED

| MODEL | COOL | HEAT | C. BREAKER |
|---------|-------|------|------------|
| WG421DC | BLACK | BLUE | 15 A |

⚠ ALL UNUSED WIRES ARE TAPED OFF

4085-321

