

INSTALLATION INSTRUCTIONS

WALL MOUNTED PACKAGED AIR CONDITIONER

Models:

WA3S3	WL3S2
WA4S3	WL4S2
WA5S3	WL5S2

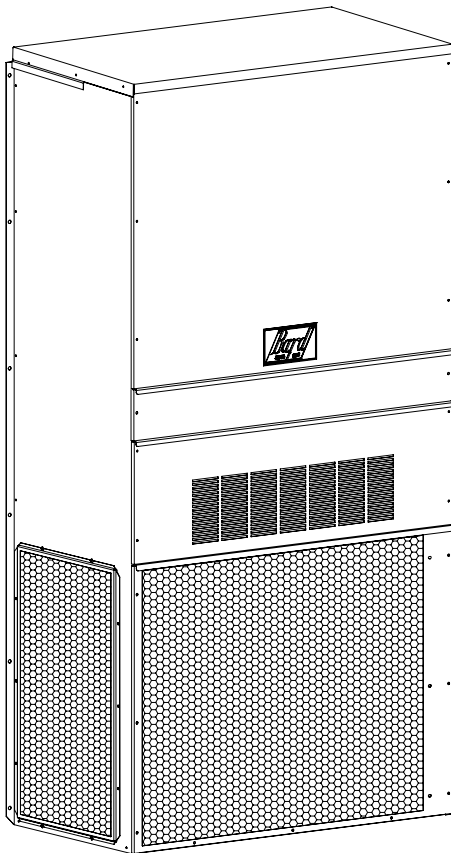

NOTE
THIS IS AN R-410A
HIGH PRESSURE
REFRIGERANT SYSTEM

MIS-2498



CLIMATE CONTROL SOLUTIONS

Bard Manufacturing Company, Inc.
Bryan, Ohio 43506
Since 1914...Moving ahead just as planned.

Manual : 2100-526E
Supersedes: 2100-526D
File: Volume III Tab 16
Date: 07-16-12

CONTENTS

Getting Other Information and Publications

For more information contact these publishers 3

Wall Mount General Information

Air Conditioner Wall Mount Model Nomenclature 4
Shipping Damage 7
General 7
Duct Work 7
Filters 7
Condensate Drain 7

Installation Instructions

Wall Mounting Information 8
Mounting the Unit 8
Typical Installations 8
Wiring – Main Power 8 & 9
Wiring – Low Voltage Wiring 12

Figures

Figure 1 Unit Dimensions 5
Figure 2 Mounting Instructions 9
Figure 3 Wall-Mounting Instructions 10
Figure 4 Wall-Mounting Instructions 10
Figure 5 Common Wall-Mounting Instructions 11
Figure 6 Electric Heat Clearance 12
Figure 7 Start-Up Label 14
Figure 8 Fan Blade Setting 17
Figure 9 Control Disassembly 21
Figure 10 Winding Test 21
Figure 11 Drip Loop 21

Start Up

General 13
Topping Off System Charge 13
Safety Practices 13
Important Installer Note 14
Crankcase Heaters 14
High & Low Pressure Switch 14
Three Phase Scroll Compressor Start Up
Information 14
Service Hints 15
Sequence of Operation 15
Compressor Control Module 15
Adjustments 16
Phase Monitor 16
Motor Start Device 16
Pressure Service Ports 16

Troubleshooting

Compressor Solenoid 17
Fan Blade Setting Dimensions 17
Removal of Fan Shroud 17
R-410A Refrigerant Charge 18
Pressure Chart 19
GE ECM™ Motors 20
GE ECM™ Motors 21
Optional Accessories 23

Tables

Table 1 Electric Heat Table 4
Table 2 Dimensions of Basic Unit 5
Table 3 Electrical Specifications 6
Table 4 Operating Voltage Range 12
Table 5 Thermostat Wire Size 12
Table 6 Wall Thermostats 12
Thermostatic Control - Dual Unit 12
Table 7 Fan Blade Dimensions 17
Table 8 Cooling Pressure 19
Table 9 Indoor Blower Performance 22
Table 10 Maximum ESP of Operation
Electric Heat Only 22
Table 11 Opt. Accessories (WA) 23
Table 12 Opt. Accessories (WL) 24

Getting Other Information and Publications

These publications can help you install the air conditioner or heat pump. You can usually find these at your local library or purchase them directly from the publisher. Be sure to consult current edition of each standard.

National Electrical Code ANSI/NFPA 70

Standard for the Installation ANSI/NFPA 90A
of Air Conditioning and
Ventilating Systems

Standard for Warm Air ANSI/NFPA 90B
Heating and Air
Conditioning Systems

Load Calculation for ACCA Manual J or
Residential Winter and Manual N
Summer Air Conditioning

Low Pressure, Low Velocity ACCA Manual D or
Duct System Design for Winter Manual Q
and Summer Air Conditioning

FOR MORE INFORMATION, CONTACT THESE PUBLISHERS:

ACCA **Air Conditioning Contractors of America**
1712 New Hampshire Ave. N.W.
Washington, DC 20009
Telephone: (202) 483-9370
Fax: (202) 234-4721

ANSI **American National Standards Institute**
11 West Street, 13th Floor
New York, NY 10036
Telephone: (212) 642-4900
Fax: (212) 302-1286

ASHRAE **American Society of Heating Refrigerating,
and Air Conditioning Engineers, Inc.**
1791 Tullie Circle, N.E.
Atlanta, GA 30329-2305
Telephone: (404) 636-8400
Fax: (404) 321-5478

NFPA **National Fire Protection Association**
Batterymarch Park
P.O. Box 9101
Quincy, MA 02269-9901
Telephone: (800) 344-3555
Fax: (617) 984-7057

Manufactured under the following U.S. patent numbers:
5,485,878; 5,301,744

WALL MOUNT GENERAL INFORMATION

AIR CONDITIONER WALL MOUNT MODEL NOMENCLATURE

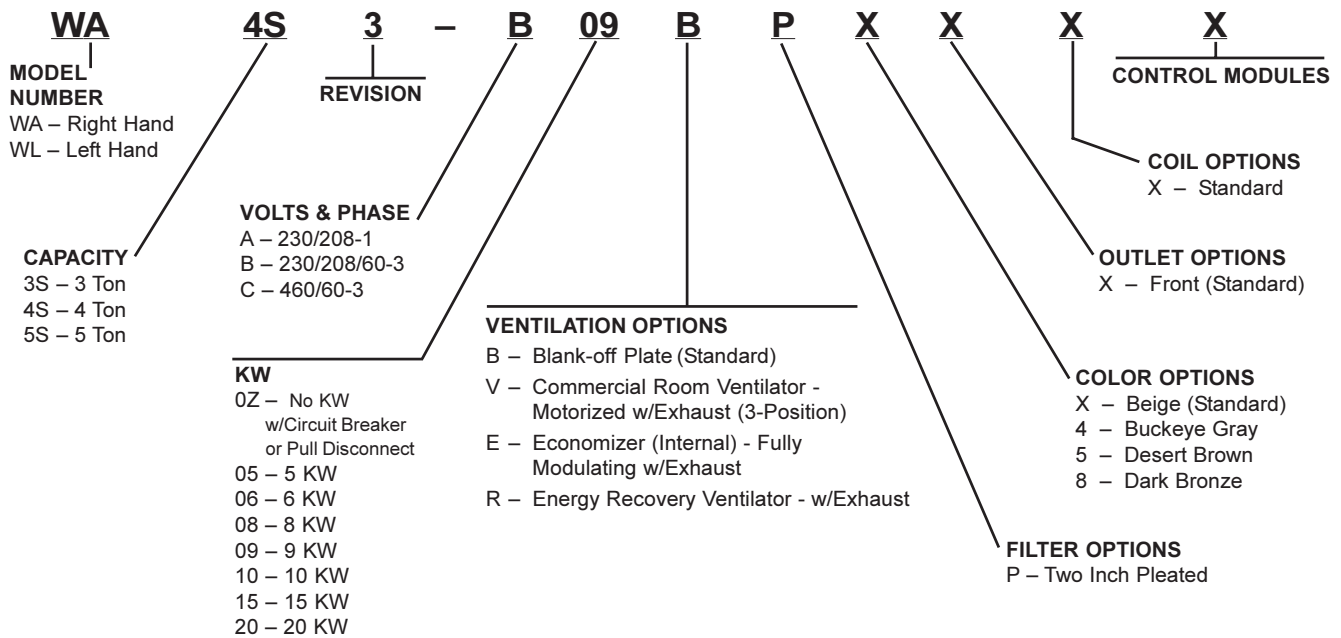

NOTE: For 0KW and circuit breakers (230/208 V) or rotary disconnects (460 V) applications, insert 0Z in the KW field of model number.

**TABLE 1
ELECTRIC HEAT TABLE**

Nominal KW	At 240V (1)				At 208V (1)				At 480V (2)			At 460V (2)		
	Kw	1-Ph Amps	3-Ph Amps	Btuh	Kw	1-Ph Amps	3-Ph Amps	Btuh	Kw	3-Ph Amps	Btuh	Kw	3-Ph Amps	Btuh
5.0	5.0	20.8		17,065	3.75	18.0		12,799						
6.0	6.0		14.4	20,478	4.50		12.5	15,359	6.0	7.2	20,478	5.52	6.9	18,840
8.0	8.0	33.3		27,304	6.00	28.8		20,478						
9.0	9.0		21.7	30,717	6.75		18.7	23,038	9.0	10.8	30,717	8.28	10.4	28,260
10.0	10.0	41.7		34,130	7.50	36.1		25,598						
15.0	15.0	62.5	36.1	51,195	11.25	54.1	31.2	38,396	15.0	18.0	51,195	13.8	17.3	47,099
20.0	20.0	83.3		68,260	15.00	72.1		51,195						

(1) These electric heaters are available in 230/208V units only.

(2) These electric heaters are available in 480V units only.

See Table 3 for Heater Availability by Model

TABLE 2

DIMENSIONS OF BASIC UNIT FOR ARCHITECTURAL & INSTALLATION REQUIREMENTS (NOMINAL)

Unit	Width W	Depth D	Height H	Supply		Return		E	F	G	I	J	K	L	M	N	O	P	Q	R	S	T	
				A	B	C	B																
WA/L3S*			84.875							31.66		32.68	26.94	34.69	32.43			23.88					
WA/L4S*	42.075	22.432	94.875	9.88	29.88	15.88	29.88	43.88	19.10	41.66	30.00	42.68	36.94	44.69	42.43	3.37	42.88	33.88	10.00	1.44	16.00	1.88	
WA/L5S*																							

All dimensions in inches. Dimensional Drawings are not to scale.

**FIGURE 1
UNIT DIMENSIONS**

**WA*S*
RIGHT
UNIT**

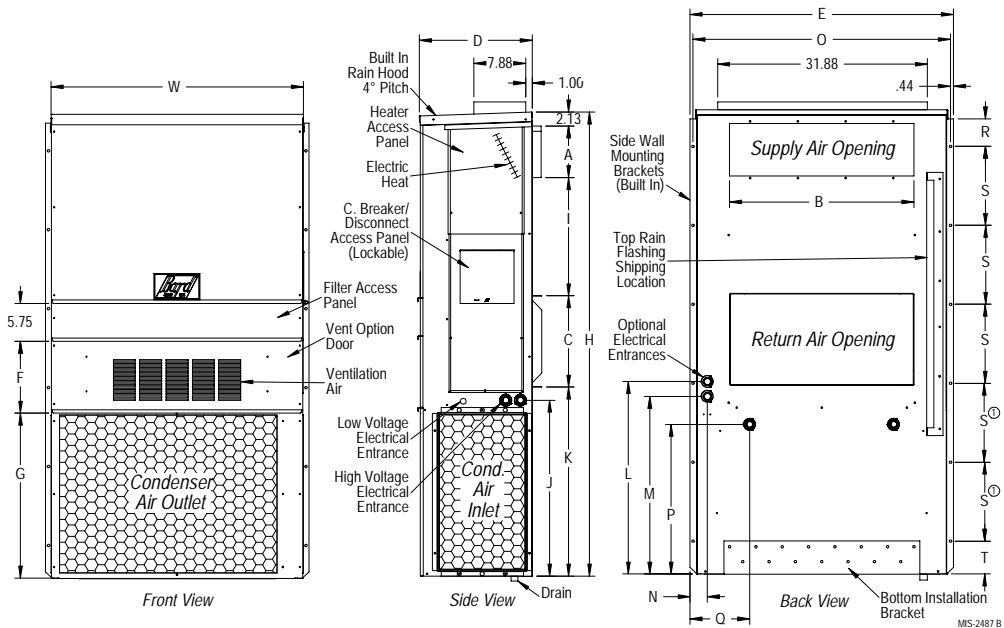

① Dimension is 21.00 inches on WA/L4S2 & WA/L5S2 models.

**WL*S*
LEFT
UNIT**

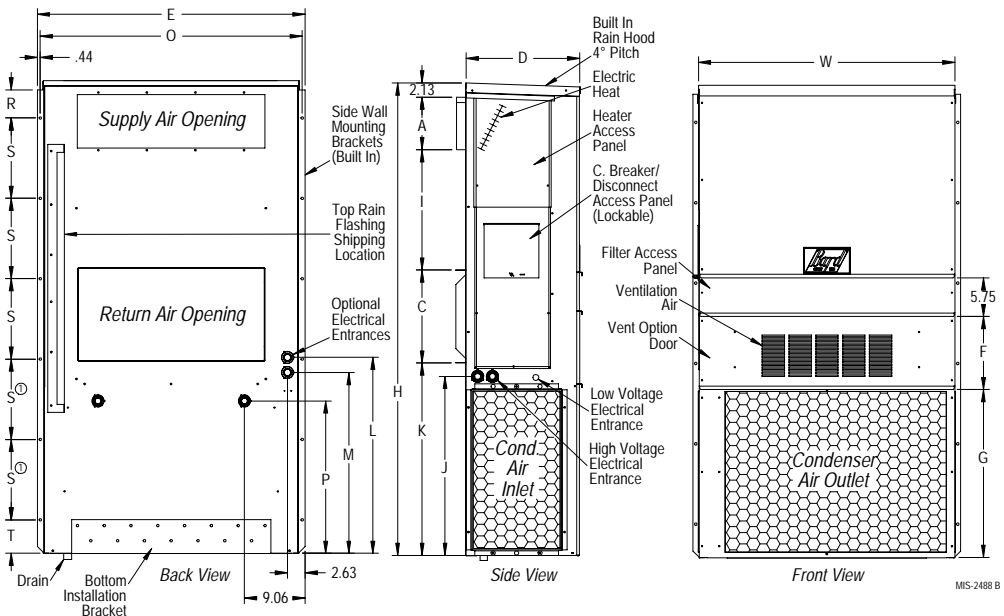

**TABLE 3
ELECTRICAL SPECIFICATIONS**

Model	Rated Volts and Phase	No. Field Power Circuits	Single Circuit				Multiple Circuit										
			① Minimum Circuit Ampacity	① Maximum External Fuse or Ckt. Brkr.	② Field Power Wire Size	② Ground Wire	③ Minimum Circuit Ampacity		① Maximum External Fuse or Ckt. Brkr.		② Field Power Wire Size		② Ground Wire				
							Ckt. A	Ckt. B	Ckt. A	Ckt. B	Ckt. A	Ckt. B	Ckt. A	Ckt. B	Ckt. A	Ckt. B	Ckt. C
WAL3S* - A0Z - A05 - A08 - A10 - A15 - A20	230/208-1	1 1 1 or 2 1 or 2 1 or 3	31 35 51 61 87 113	45 45 70 90 115	8 8 6 3 2	10 10 8 8 6	35 26 52 52	45 30 45 45	8 8 8	10 10 6 6	10 10 10 10						
WAL3S* - B0Z - B06 - B09 - B15	230/208-3	1 1 1 1	23 27 36 55	30 30 40 60	10 10 8 6	10 10 10 10											
WAL3S* - C0Z - C06 - C09 - C15	460-3	1 1 1 1	12 13.5 19 28	15 15 20 30	14 14 12 10	14 14 12 10											
WAL4S* - A0Z - A05 - A08 - A10 - A15 - A20	230/208-1	1 1 1 or 2 1 or 2 1 or 3	38 38 53 63 89 115	45 45 60 70 90 120	8 8 6 4 3 2	10 10 10 8 8 6	37 26 52 52	45 30 45 45	8 8 8	10 10 6 6	10 10 10 10						
WAL4S* - B0Z - B06 - B09 - B15	230/208-3	1 1 1 1	28 29 38 56	40 40 40 60	10 10 8 6	10 10 10 10											
WAL4S* - C0Z - C06 - C09 - C15	460-3	1 1 1 1	15 16 21 30	20 20 25 30	12 12 10 10	12 12 10 10											
WAL5S* - A0Z - A05 - A08 - A10 - A15 - A20	230/208-1	1 1 1 or 2 1 or 2 1 or 3	44 44 53 63 89 115	50 50 60 70 90 120	8 8 6 3 2	10 10 10 8 8 6	44 26 52 52	50 30 50 50	8 8 8	10 10 6 6	10 10 10 10						
WAL5S* - B0Z - B06 - B09 - B15	230/208-3	1 1 1 1	34 34 38 56	40 40 40 60	8 8 8 6	10 10 10 10											
WAL5S* - C0Z - C06 - C09 - C15	460-3	1 1 1 1	17 17 21 30	25 25 25 30	10 10 10 10	10 10 10 10											

① Maximum size of the time delay fuse or HACR type circuit breaker for protection of field wiring conductors.
 ② Based on 75°C copper wire. All wiring must conform to the National Electric Code (NEC) and all local codes.
 ③ These "Minimum Circuit Ampacity" values are to be used for sizing the field power conductors. Refer to the National Electric Code (latest version), Article 310 for power conductor sizing. **CAUTION: When more than one filed power conductor circuit is run through one conduit, the conductors must be derated. Pay special attention to Note * of Table 310 regarding Ampacity Adjustment Factors when more than 3 conductors are in a raceway.**

SHIPPING DAMAGE

Upon receipt of equipment, the carton should be checked for external signs of shipping damage. If damage is found, the receiving party must contact the last carrier immediately, preferably in writing, requesting inspection by the carrier's agent.

GENERAL

The equipment covered in this manual is to be installed by trained, experienced service and installation technicians.

The refrigerant system is completely assembled and charged. All internal wiring is complete.

The unit is designed for use with or without duct work. Flanges are provided for attaching the supply and return ducts.

These instructions explain the recommended method to install the air cooled self-contained unit and the electrical wiring connections to the unit.

These instructions and any instructions packaged with any separate equipment required to make up the entire air conditioning system should be carefully read before beginning the installation. Note particularly "Starting Procedure" and any tags and/or labels attached to the equipment.

While these instructions are intended as a general recommended guide, they do not supersede any national and/or local codes in any way. Authorities having jurisdiction should be consulted before the installation is made. See Page 3 for information on codes and standards.

Size of unit for a proposed installation should be based on heat loss calculation made according to methods of Air Conditioning Contractors of America (ACCA). The air duct should be installed in accordance with the Standards of the National Fire Protection Association for the Installation of Air Conditioning and Ventilating Systems of Other Than Residence Type, NFPA No. 90A, and Residence Type Warm Air Heating and Air Conditioning Systems, NFPA No. 90B. Where local regulations are at a variance with instructions, installer should adhere to local codes.

DUCT WORK

All duct work, supply and return, must be properly sized for the design airflow requirement of the equipment. Air Conditioning Contractors of America (ACCA) is an excellent guide to proper sizing. All duct work or portions thereof not in the conditioned space should be properly insulated in order to both conserve energy and prevent condensation or moisture damage.

Refer to Table 10 for maximum static pressure available for duct design.

Design the duct work according to methods given by the Air Conditioning Contractors of America (ACCA). When duct runs through unheated spaces, it should be insulated with a minimum of 1-inch of insulation. Use insulation with a vapor barrier on the outside of the insulation. Flexible joints should be used to connect the duct work to the equipment in order to keep the noise transmission to a minimum.

A 1/4 inch clearance to combustible material for the first three feet of duct attached to the outlet air frame is required. See Wall Mounting Instructions and Figures 3 and 4 for further details.

Ducts through the walls must be insulated and all joints taped or sealed to prevent air or moisture entering the wall cavity.

CAUTION

Some installations may not require any return air duct. A return air grille is required with installations not requiring a return air duct. The spacing between louvers on the grille shall not be larger than 5/8 inches.

Any grille that meets the 5/8 inch louver criteria, may be used. It is recommended that Bard Return Air Grille Kit RG-5 or RFG-5 be installed when no return duct is used. Contact distributor or factory for ordering information. If using a return air filter grille, filters must be of sufficient size to allow a maximum velocity of 400 fpm.

NOTE: If no return air duct is used, applicable installation codes may limit this cabinet to installation only in a single story structure.

FILTERS

A 2-inch pleated filter is supplied with each unit. The filter slides into position making it easy to service. This filter can be serviced from the outside by removing the filter access panel. The internal filter brackets are adjustable to accommodate the 1-inch filter by bending up the tabs to allow spacing for the 1-inch filters.

CONDENSATE DRAIN

A plastic drain hose extends from the drain pan at the top of the unit down to the unit base. There are openings in the unit base for the drain hose to pass through. In the event the drain hose is connected to a drain system of some type, it must be an open or vented type system to assure proper drainage.

INSTALLATION INSTRUCTIONS

WALL MOUNTING INFORMATION

1. Two holes, for the supply and return air openings, must be cut through the wall as shown in Figure 3.
2. On wood-frame walls, the wall construction must be strong and rigid enough to carry the weight of the unit without transmitting any unit vibration. See Figures 4 and 5.



WARNING

Fire hazard can result if 1/4 inch clearance to combustible materials for supply air duct is not maintained. See Figure 3.

3. Concrete block walls must be thoroughly inspected to insure that they are capable of carrying the weight of the installing unit. See Figure 4.

MOUNTING THE UNIT

1. These units are secured by wall mounting brackets which secure the unit to the outside wall surface at both sides. A bottom mounting bracket is provided for ease of installation.
2. The unit itself is suitable for "0" inch clearance, but the supply air duct flange and the first 3 feet of supply air duct require a minimum of 1/4 inch clearance to combustible material. If a combustible wall, use a minimum of 30-1/2" x 10-1/2" dimensions for sizing. However, it is generally recommended that a 1-inch clearance is used for ease of installation and maintaining the required clearance to combustible material. The supply air opening would then be 32" x 12". See Figures 2, 3 and 6 for details.



WARNING

Failure to provide the 1/4 inch clearance between the supply duct and a combustible surface for the first 3 feet of duct can result in fire.

3. Locate and mark lag bolt locations and bottom mounting bracket location. See Figure 4.
4. Mount bottom mounting bracket.
5. Hook top rain flashing under back bend of top. Top rain flashing is shipped secured to the right side of the back.
6. Position unit in opening and secure with 5/16 lag bolts; use 7/8 inch diameter flat washers on the lag bolts.
7. Secure rain flashing to wall and caulk across entire length of top. See Figure 2.
8. For additional mounting rigidity, the return air and supply air frames or collars can be drilled and screwed or welded to the structural wall itself (depending upon wall construction). Be sure to observe required clearance if combustible wall.
9. On side-by-side installations, maintain a minimum of 20 inches clearance on right side to allow access to heat strips and control panel and to allow proper airflow to the outdoor coil. Additional clearance may be required to meet local or national codes.

TYPICAL INSTALLATIONS

See Figure 5 for common ways to install the wall mount unit.

WIRING — MAIN POWER

Refer to the unit rating plate for wire sizing information and maximum fuse or "HACR" type circuit breaker size. Each outdoor unit is marked with a "Minimum Circuit Ampacity". This means that the field wiring used must be sized to carry that amount of current. Depending on the installed KW of electric heat, there may be two field power circuits required. If this is the case, the unit serial plate will so indicate. All models are suitable only for connection with copper wire. Each unit and/or wiring diagram will be marked "Use Copper Conductors Only". These instructions **must be** adhered to. Refer to the National Electrical Code (NEC) for complete current carrying capacity data on the various insulation grades of wiring material. All wiring must conform to NEC and all local codes.

The electrical data lists fuse and wire sizes (75°C copper) for all models, including the most commonly used heater sizes. Also shown are the number of field power circuits required for the various models with heaters.

The unit rating plate lists a “Maximum Time Delay Relay Fuse” or “HACR” type circuit breaker that is to be used with the equipment. The correct size must be used for proper circuit protection and also to assure that there will be no nuisance tripping due to the momentary high starting current of the compressor motor.

The disconnect access door on this unit may be locked to prevent unauthorized access to the disconnect.

To convert for the locking capability, bend the tab located in the bottom left hand corner of the disconnect opening under the disconnect access panel straight out. This tab will now line up with the slot in the door. When shut, a padlock may be placed through the hole in the tab preventing entry.

See Start-up section for information on three phase scroll compressor start-ups.

FIGURE 2
MOUNTING INSTRUCTIONS

NOTE: It is recommended that a bead of silicone caulking be placed behind the side mounting flanges and under the top flashing at the time of installation.

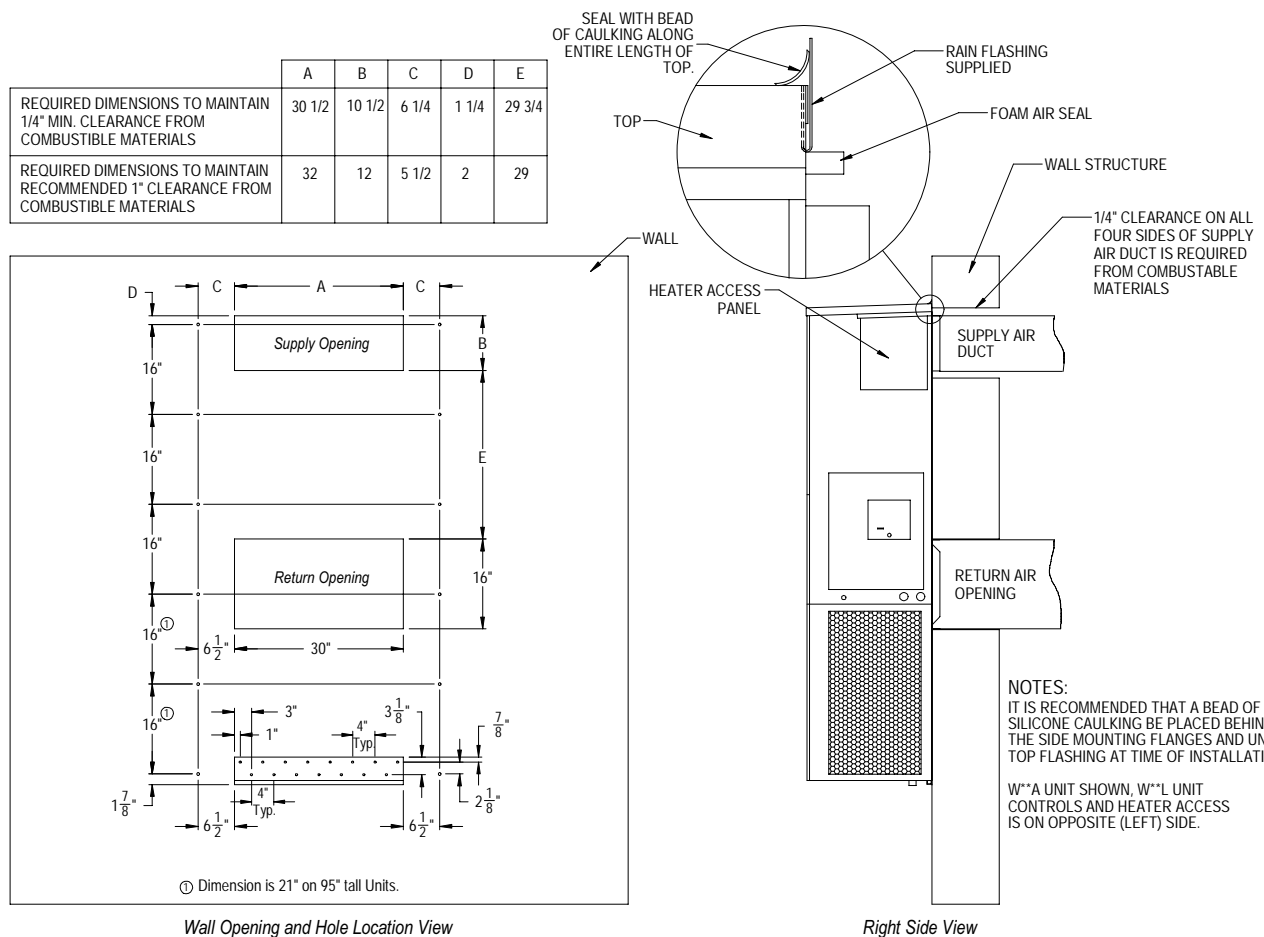

MIS-416 D

FIGURE 3 WALL-MOUNTING INSTRUCTIONS

SEE FIGURE 3 — MOUNTING INSTRUCTIONS

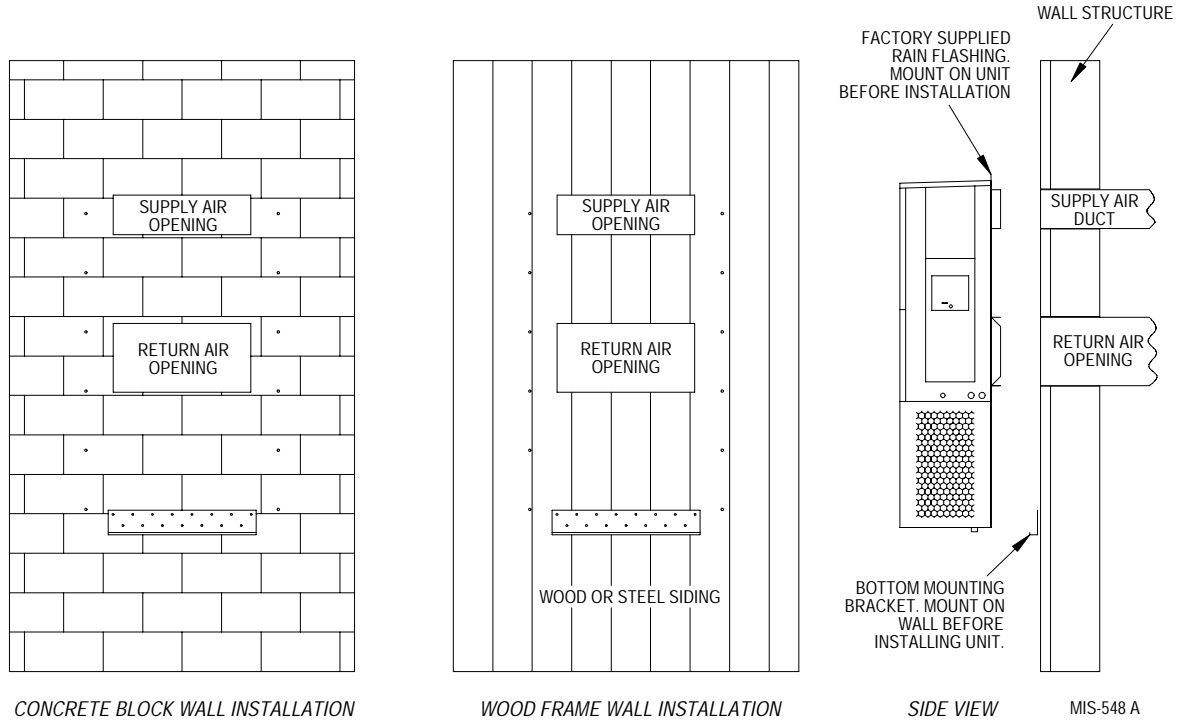
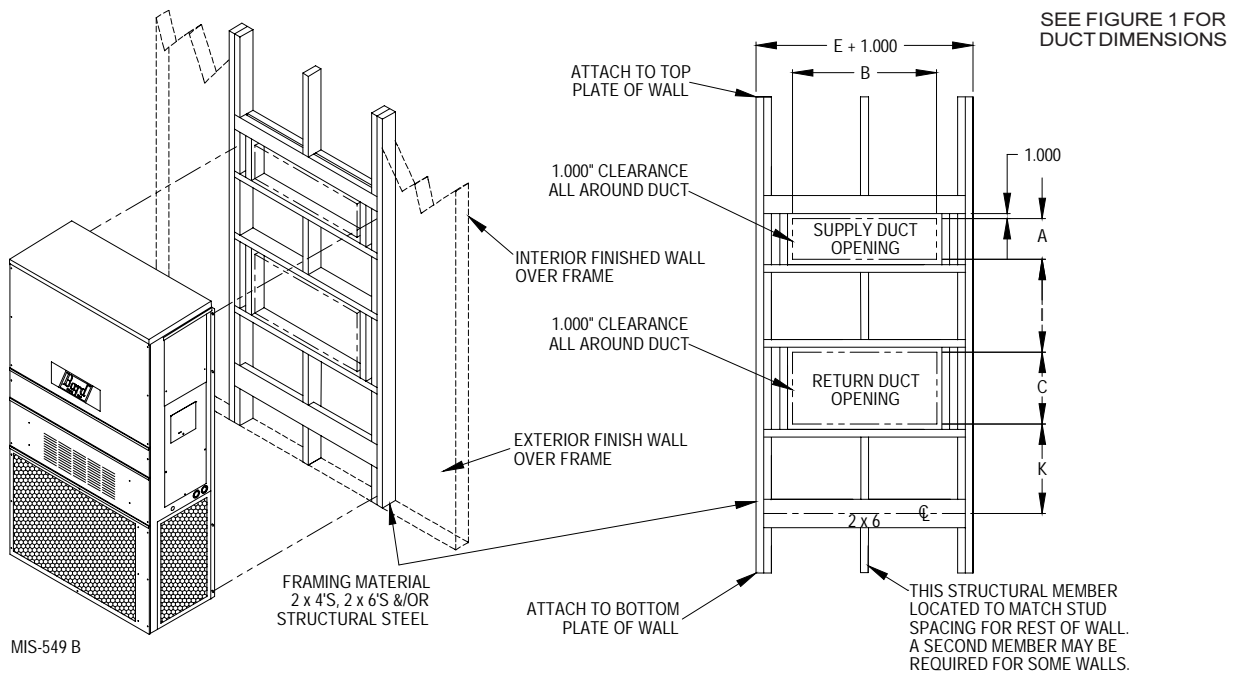
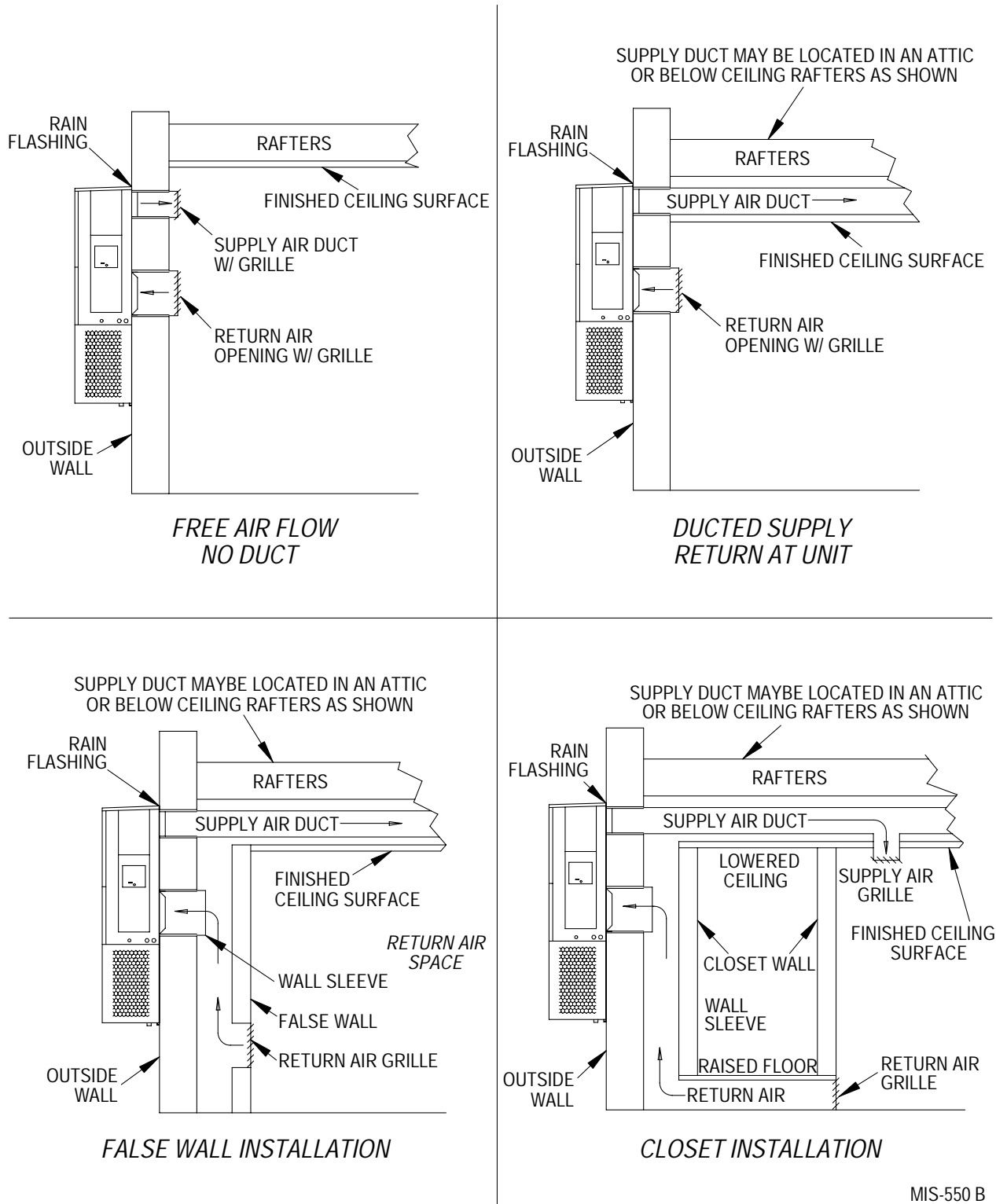

FIGURE 4 WALL-MOUNTING INSTRUCTIONS

SEE UNIT DIMENSIONS, FIGURE 1,
FOR ACTUAL DIMENSIONS

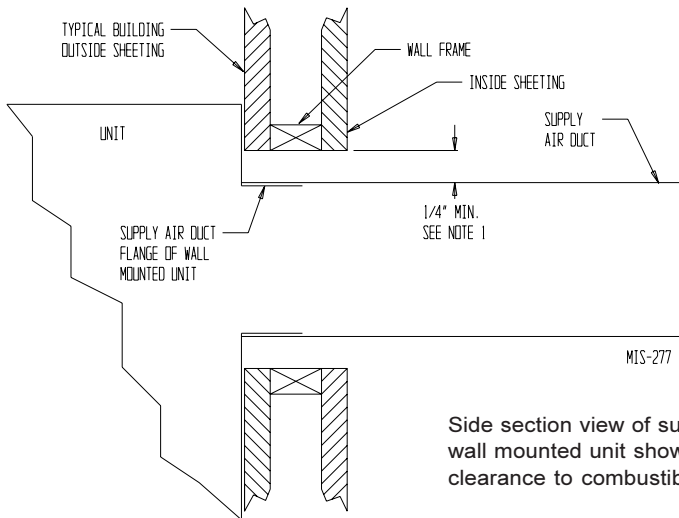

**FIGURE 5
COMMON WALL-MOUNTING INSTALLATIONS**



MIS-550 B

**FIGURE 6
ELECTRIC HEAT CLEARANCE**



Side section view of supply air duct for wall mounted unit showing 1/4 inch clearance to combustible surfaces.



WARNING

- A minimum of 1/4 inch clearance must be maintained between the supply air duct and combustible materials. This is required for the first 3 feet of ducting.
- It is important to insure that the 1/4 inch minimum spacing is maintained at all points.
- Failure to do this could result in overheating the combustible material and may result in fire.

WIRING — LOW VOLTAGE WIRING

230/208V, 1 phase and 3 phase are equipped with dual primary voltage transformers. All equipment leaves the factory wired on 240V tap. For 208V operation, reconnect from 240V to 208V tap. The acceptable operating voltage range for the 240 and 208V taps are shown in Table 4 below.

**TABLE 4
OPERATING VOLTAGE RANGE**

TAP	RANGE
240V	253 - 216
208V	220 - 187

**TABLE 6
WALL THERMOSTATS**

Thermostat	Predominant Features
8403-060 (1120-445)	3 stage Cool; 3 stage Heat Programmable/Non-Programmable Electronic HP or Conventional Auto or Manual changeover
8403-058 (TH5220D1151)	2 stage Cool; 2 stage Heat Electronic Non-Programmable Auto or Manual changeover

NOTE: The voltage should be measured at the field power connection point in the unit and while the unit is operating at full load (maximum amperage operating condition).

Eight (8) wires should be run from thermostat subbase to the 24V terminal board in the unit. An eight conductor, 18 gauge copper, color-coded thermostat cable is recommended. See Manual 2100-507 (latest revision) for low voltage wiring options.

**TABLE 5
THERMOSTAT WIRE SIZE**

Transformer VA	FLA	Wire Gauge	Maximum Distance in Feet
50	2.1	20 gauge	45
		18 gauge	60
		16 gauge	100
		14 gauge	160
		12 gauge	250

**THERMOSTATIC CONTROL
FOR DUAL UNIT APPLICATION**

Thermostat	Predominate Features	Bard Specifications
TEC 40	2-Unit / 2-Stage Heat / 2-Stage Cool Controller	See Spec. Sheet S3353
MC3000	2-Unit / 2-Stage Heat / 2-Stage Cool Controller with Option Alarms	See Spec. Sheet S3379

These units require R-410A refrigerant and Polyol Ester oil.

GENERAL:

1. Use separate service equipment to avoid cross contamination of oil and refrigerants.
2. Use recovery equipment rated for R-410A refrigerant.
3. Use manifold gauges rated for R-410A (800 psi/250 psi low).
4. R-410A is a binary blend of HFC-32 and HFC-125.
5. R-410A is nearly azeotropic - similar to R-22 and R-12. Although nearly azeotropic, charge with liquid refrigerant.
6. R-410A operates at 40-70% higher pressure than R-22, and systems designed for R-22 cannot withstand this higher pressure.
7. R-410A has an ozone depletion potential of zero, but must be reclaimed due to its global warming potential.
8. R-410A compressors use Polyol Ester oil.
9. Polyolester oil is hygroscopic; it will rapidly absorb moisture and strongly hold this moisture in the oil.
10. A liquid line dryer must be used - even a deep vacuum will not separate moisture from the oil.
11. Limit atmospheric exposure to 15 minutes.
12. If compressor removal is necessary, always plug compressor immediately after removal. Purge with small amount of nitrogen when inserting plugs.

TOPPING OFF SYSTEM CHARGE

If a leak has occurred in the system, Bard Manufacturing recommends reclaiming, evacuating (see criteria above), and charging to the nameplate charge. Topping off the system charge can be done without problems.

With R-410A, there are no significant changes in the refrigerant composition during multiple leaks and recharges. R-410A refrigerant is close to being an azeotropic blend (it behaves like a pure compound or single component refrigerant). The remaining refrigerant charge, in the system, may be used after leaks have occurred and then “top-off” the charge by utilizing the pressure charts on the inner control panel cover as a guideline.

REMEMBER: When adding R-410A refrigerant, it must come out of the charging cylinder/tank as a liquid to avoid any fractionation, and to insure optimal system performance. Refer to instructions for the cylinder that is being utilized for proper method of liquid extraction.

SAFETY PRACTICES:

1. Never mix R-410A with other refrigerants.
2. Use gloves and safety glasses, Polyol Ester oils can be irritating to the skin, and liquid refrigerant will freeze the skin.
3. Never use air and R-410A to leak check; the mixture may become flammable.
4. Do not inhale R-410A – the vapor attacks the nervous system, creating dizziness, loss of coordination and slurred speech. Cardiac irregularities, unconsciousness and ultimate death can result from breathing this concentration.
5. Do not burn R-410A. This decomposition produces hazardous vapors. Evacuate the area if exposed.
6. Use only cylinders rated DOT4BA/4BW 400.
7. Never fill cylinders over 80% of total capacity.
8. Store cylinders in a cool area, out of direct sunlight.
9. Never heat cylinders above 125°F.
10. Never trap liquid R-410A in manifold sets, gauge lines or cylinders. R-410A expands significantly at warmer temperatures. Once a cylinder or line is full of liquid, any further rise in temperature will cause it to burst.

START UP CONTINUED

IMPORTANT INSTALLER NOTE

For improved start-up performance, wash the indoor coil with a dishwasher detergent.

CRANKCASE HEATERS

All units covered in this manual are provided with compressor crankcase heat.

This crankcase heater is a band type heater located around the bottom of the compressor. This heater is controlled by the crankcase heater relay. The heater is only energized when the compressor is not running.

Crankcase heat is essential to prevent liquid refrigerant from migrating to the compressor, preventing oil pump out on compressor start-up and possible bearing or scroll vane failure due to compressing a liquid.

The decal in Figure 7 is affixed to all model units detailing start-up procedure. This is very important. *Please read carefully.*

FIGURE 7
START-UP LABEL

IMPORTANT

These procedures must be followed at initial start-up and at any time power has been removed for 12 hours or longer.

To prevent compressor damage which may result from the presence of liquid refrigerant in the compressor crankcase.

1. Make certain the room thermostat is in the "off" position (the compressor is not to operate).
2. Apply power by closing the system disconnect switch. This energizes the compressor heater which evaporates the liquid refrigerant in the crankcase.
3. Allow 4 hours or 60 minutes per pound of refrigerant in the system as noted on the unit rating plate, whichever is greater.
4. After properly elapsed time, the thermostat may be set to operate the compressor.
5. Except as required for safety while servicing – **Do not open system disconnect switch.**

7961-061

HIGH & LOW PRESSURE SWITCH

All models covered by this Manual are supplied with a remote reset high pressure switch and low pressure switch. If tripped, this pressure switch may be reset by turning the thermostat off then back on again.

THREE PHASE SCROLL COMPRESSOR START UP INFORMATION

Scroll compressors, like several other types of compressors, will only compress in one rotational direction. Direction of rotation is not an issue with single phase compressors since they will always start and run in the proper direction.

However, three phase compressors will rotate in either direction depending upon phasing of the power. Since there is a 50-50 chance of connecting power in such a way as to cause rotation in the reverse direction, verification of proper rotation must be made. All three phase units incorporate a phase monitor to ensure proper field wiring. See the "Phase Monitor" section later in this manual.

Verification of *proper rotation* must be made any time a compressor is change or rewired. If improper rotation is corrected at this time there will be no negative impact on the durability of the compressor. However, reverse operation for over one hour may have a negative impact on the bearing due to oil pump out.

NOTE: If compressor is allowed to run in reverse rotation for several minutes, the compressor's internal protector will trip.

All three phase ZPS compressors are wired identically internally. As a result, once the correct phasing is determined for a specific system or installation, connecting properly phased power leads to the same Fusite terminal should maintain proper rotation direction.

Verification of proper rotation direction is made by observing that suction pressure drops and discharge pressure rises when the compressor is energized. Reverse rotation also results in an elevated sound level over that with correct rotations, as well as, substantially reduced current draw compared to tabulated values.

The direction of rotation of the compressor may be changed by reversing any two line connections to the unit.

See "Phase Monitor", Page 16.

SERVICE HINTS

1. Maintain clean air filters at all times. Also, do not close off or block supply and return air registers. This reduces air flow through the system, which shortens equipment service life as well as increasing operating costs.
2. Check all power fuses or circuit breakers to be sure they are the correct rating.
3. Periodic cleaning of the outdoor coil to permit full and unrestricted airflow circulation is essential.

Frequency of coil cleaning will depend on duty cycle of equipment, type of use and installation site variables. Telecommunication type installations in high traffic areas or in areas none too frequent to airborne debris, will require more frequent coil maintenance than those in areas not subject to those conditions.

SEQUENCE OF OPERATION

NON-ECONOMIZER

Stage 1 (Y1) cooling call activates Step 1 (partial capacity, 66%) of compressor capacity.

Stage 2 (Y2) cooling call activates Step 2 (full capacity, 100%) of compressor capacity.

WITH ECONOMIZER

Stage 1 (Y1) cooling call goes to economizer controls for decision:

- If Enthalpy Control decides outdoor conditions are suitable for free cooling, the economizer will operate.
 - If Stage 2 cooling call is issued during economizer operation, the economizer will close and the compressor will go straight to Step 2 full capacity operation.
- If Enthalpy Control decides outdoor conditions are not suitable for free cooling, the economizer will not operate (or close) and Step 1 of the compressor will operate.
 - If Stage 2 cooling call is issued, the compressor will shift to Step 2 full cooling capacity operation.

COMPRESSOR CONTROL MODULE

The compressor control module is standard on the models covered by this manual. The compressor control is an anti-short cycle/lockout timer with high and low pressure switch monitoring and alarm relay output.

Adjustable Delay On Make And Break Timer

On initial power up or anytime power is interrupted to the unit, the *delay on make* period begins, which will be 2 minutes plus 10% of the *delay on break* setting. When the delay on make is complete and the high pressure and low pressure switches are closed, the compressor contactor is energized. Upon shutdown the delay or break timer starts and prevents restart until the delay on break and delay on make periods have expired.

During routine operation of the unit with no power interruptions, the compressor will operate on demand with no delay.

High Pressure Switch and Lockout Sequence

If the high pressure switch opens, the compressor contactor will de-energize immediately. The lockout timer will go into a *soft lockout* and stay in soft lockout until the high pressure switch closes and the delay on break time has expired. If the high pressure switch opens again in this same operating cycle, the unit will go into *manual lockout* condition and the alarm relay circuit will energize. Recycling the wall thermostat resets the manual lockout.

Low Pressure Switch, Bypass and Lockout Sequence

If the low pressure switch opens for more than 120 seconds, the compressor contactor will de-energize and go into a soft lockout. Regardless the state of the low pressure switch, the contactor will reenergize after the delay on make time delay has expired. If the low pressure switch remains open, or opens again for longer than 120 seconds the unit will go into manual lockout condition and the alarm relay circuit will energize. Recycling the wall thermostat resets the manual lockout.

Optional Low Ambient Control

An optional low ambient control is available for both factory and field installed options. The low ambient control is to be applied to the WA3S/WA4S/WA5S models when operation below 50° outdoor conditions are anticipated. Without this device, the evaporating pressure would fall off, and the indoor coil would ice over.

The fan cycling control cycles the fan motor on, once the liquid refrigerant pressure reaches 350 psig, and off, once it has dropped to 225 psig. It will continue to cycle between these parameters depending on outdoor temperatures and the load/stage of the system.

This cycling maintains a minimum liquid pressure affecting the minimum suction pressure. This effect insures an evaporating temperature that is slightly above the point of ice formation on the evaporator.

Alarm Relay Output

Alarm terminal is output connection for applications where alarm relay is employed. This terminal is powered whenever compressor is locked out due to HPC or LPC sequences as described.

NOTE: Both high and low pressure switch controls are inherently automatic reset devices. The high pressure switch and low pressure switch cut out and cut in settings are fixed by specific air conditioner or heat pump unit model. The lockout features, both soft and manual, are a function of the Compressor Control Module.

ADJUSTMENTS

Adjustable Delay on Make and Delay on Break Timer

The potentiometer is used to select Delay on Break time from 30 seconds to 5 minutes. Delay on Make (DOM) timing on power-up and after power interruptions is equal to 2 minutes plus 10% of Delay on Break (DOB) setting:

0.5 minute (30 seconds)	DOB =123 second	DOM
1.0 minute (60 seconds)	DOB =126 second	DOM
2.0 minute (120 seconds)	DOB =132 second	DOM
3.0 minute (180 seconds)	DOB =138 second	DOM
4.0 minute (240 seconds)	DOB =144 second	DOM
5.0 minute (300 seconds)	DOB =150 second	DOM

During routine operation of the unit with no power interruptions the compressor will operate on demand with no delay.

Typical Settings for Dual Unit Installation:

Unit 1: DOB set at 2 minutes, and DOM is 132 seconds

Unit 2: DOB set at 4 minutes, and DOM is 144 seconds

PHASE MONITOR

All units with three phase scroll compressors are equipped with a 3-phase line monitor to prevent compressor damage due to phase reversal.

The phase monitor in this unit is equipped with two LEDs. If the Y signal is present at the phase monitor and phases are correct the green LED will light.

If phases are reversed, the red fault LED will be lit and compressor operation is inhibited.

If a fault condition occurs, reverse two of the supply leads to the unit. Do not reverse any of the unit factory wires as damage may occur.

MOTOR START DEVICE

Single Phase (-A) model compressor circuits are equipped with a 25 ohm PTCR (Positive Temperature Coefficient Resistor) motor starting device as standard equipment.

The PTCR is wired in parallel with the run capacitor. When voltage is applied, and device is cool, its low resistance permits a large current to flow in the auxiliary windings - increasing the motors available starting torque. The device then rapidly heats up, and the current levels drop to a few milliamperes. The PTCR then becomes self-regulating, passing just enough current to maintain its temperature to remain in the high resistance state. Once the voltage source is removed, the device then cools down and the resistance drops, and is then ready for the next compressor start cycle.

PRESSURE SERVICE PORTS

High and low pressure service ports are installed on all units so that the system operating pressures can be observed. Pressure tables can be found later in the manual covering all models. It is imperative to match the correct pressure table to the unit by model number.

Be careful to observe whether unit is operating in high cool or low cool when utilizing the charts.

TROUBLESHOOTING

COMPRESSOR SOLENOID

(See *Sequence of Operation on Page 15 for function.*) A nominal 24-volt direct current coil activates the internal compressor solenoid. The input control circuit voltage must be 18 to 28 volt ac. The coil power requirement is 20 VA. The external electrical connection is made with a molded plug assembly. This plug contains a full wave rectifier to supply direct current to the unloader coil.

Compressor Solenoid Test Procedure If it is suspected that the unloader is not working, the following methods may be used to verify operation.

1. Operate the system and measure compressor amperage. Cycle the compressor solenoid on and off at ten-second intervals. The compressor amperage should go up or down at least 25 percent.
2. If step one does not give the expected results, shut unit off. Apply 18 to 28 volt ac to the solenoid molded plug leads and listen for a click as the solenoid pulls in. Remove power and listen for another click as the solenoid returns to its original position.
3. If clicks can't be heard, shut off power and remove the control circuit molded plug from the compressor and measure the solenoid coil resistance. The resistance should be 32 to 60 ohms depending on compressor temperature.
4. Next, check the molded plug.

Voltage check: Apply control voltage to the plug wires (18 to 28 volt ac). The measured **dc** voltage at the female connectors in the plug should be around 15 to 27 vdc.

Resistance check: Measure the resistance from the end of one molded plug lead to either of the two female connectors in the plug. One of the connectors should read close to zero ohms, while the other should read infinity. Repeat with other wire. The same female connector as before should read zero, while the other connector again reads infinity. Reverse polarity on the ohmmeter leads and repeat. The female connector that read infinity previously should now read close to zero ohms.

Replace plug if either of these test methods does not show the desired results.

FAN BLADE SETTING DIMENSIONS

Shown in the drawing below are the correct fan blade setting dimensions for proper air delivery across the outdoor coil. See Figure 8.

Any service work requiring removal or adjustment in the fan and/or motor area will require that the dimensions below be checked and blade adjusted in or out on the motor shaft accordingly. See Table 7.

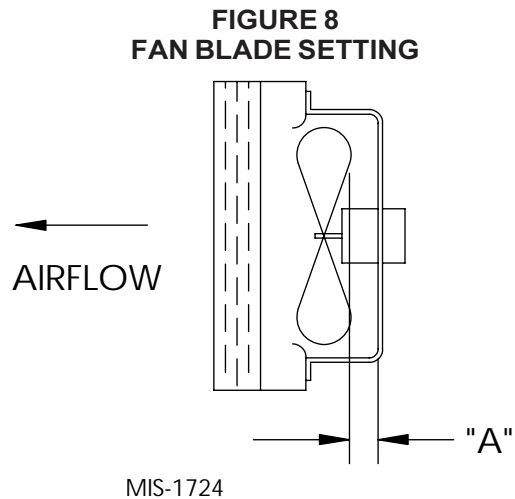

**TABLE 7
FAN BLADE DIMENSIONS**

Model	Dimension A
WAL3S*	1.75"
WAL4S*	
WAL5S*	

REMOVAL OF FAN SHROUD

1. Disconnect all power to unit.
2. Remove the screws holding both grills – one on each side of unit – and remove grills.
3. Remove screws holding fan shroud to condenser and bottom – (9) screws.
4. Unwire condenser fan motor.
5. Slide complete motor, fan blade, and shroud assembly out the left side of the unit.
6. Service motor/fan as needed.
7. Reverse steps to reinstall.

TROUBLESHOOTING CONT'D.

R-410A

REFRIGERANT CHARGE

This unit was charged at the factory with the quantity of refrigerant listed on the serial plate. AHRI capacity and efficiency ratings were determined by testing with this refrigerant charge quantity.

The following pressure tables show nominal pressures for the units. Since many installation specific situations can affect the pressure readings, this information should only be used by certified technicians as a guide for evaluating proper system performance. They shall not be used to adjust charge. If charge is in doubt, reclaim, evacuate and recharge the unit to the serial plate charge.

**TABLE 8
COOLING PRESSURE – (ALL TEMPERATURES °F)**

HIGH CAPACITY COOLING			AIR TEMPERATURE ENTERING OUTDOOR COIL DEGREE F													
MODEL	RETURN AIR TEMPERATURE	PRESSURE	50°F	55°F	60°F	65°F	70°F	75°F	80°F	85°F	90°F	95°F	100°F	105°F	110°F	115°F
WA3S* WL3S*	75° DB	LOW SIDE	112	115	119	122	126	129	131	132	134	135	136	138	139	140
	62° WB	HIGH SIDE	195	214	233	253	272	291	314	337	360	383	409	435	461	487
	80° DB	LOW SIDE	124	127	131	134	138	141	142	144	145	147	148	149	151	152
	67° WB	HIGH SIDE	201	220	239	259	278	297	319	341	363	390	413	440	468	495
	85° DB	LOW SIDE	135	138	142	145	149	152	154	156	157	159	161	162	164	165
	72° WB	HIGH SIDE	205	224	243	263	282	301	326	350	375	399	425	451	476	502
WA4S* WL4S*	75° DB	LOW SIDE	117	119	121	123	125	127	128	130	131	132	133	135	136	137
	62° WB	HIGH SIDE	197	216	235	255	274	293	316	339	361	383	410	438	466	494
	80° DB	LOW SIDE	127	129	131	134	136	138	138	139	139	143	143	144	146	149
	67° WB	HIGH SIDE	201	220	239	259	278	298	318	341	364	400	415	443	471	500
	85° DB	LOW SIDE	141	143	145	148	150	152	152	153	153	154	156	158	160	162
	72° WB	HIGH SIDE	203	223	243	263	283	303	326	349	372	396	422	449	478	508
WA5S* WL5S*	75° DB	LOW SIDE	118	119	120	122	123	125	126	128	129	130	132	133	135	136
	62° WB	HIGH SIDE	199	217	236	260	285	309	333	357	381	405	432	460	487	514
	80° DB	LOW SIDE	129	130	131	131	132	132	134	137	139	141	143	145	146	148
	67° WB	HIGH SIDE	205	224	247	270	292	315	339	363	387	425	438	465	492	519
	85° DB	LOW SIDE	137	139	140	141	142	143	146	148	151	153	155	157	158	160
	72° WB	HIGH SIDE	216	237	258	279	300	321	346	370	395	419	447	474	502	529

LOW CAPACITY COOLING			AIR TEMPERATURE ENTERING OUTDOOR COIL DEGREE F													
MODEL	RETURN AIR TEMPERATURE	PRESSURE	50°F	55°F	60°F	65°F	70°F	75°F	80°F	85°F	90°F	95°F	100°F	105°F	110°F	115°F
WA3S* WL3S*	75° DB	LOW SIDE	126	127	129	130	132	133	135	136	138	139	141	144	146	148
	62° WB	HIGH SIDE	181	198	215	233	250	267	289	310	332	353	378	404	429	454
	80° DB	LOW SIDE	137	138	139	141	142	143	145	147	149	151	153	155	156	158
	67° WB	HIGH SIDE	184	201	218	236	253	270	291	312	333	354	380	406	432	458
	85° DB	LOW SIDE	153	154	155	156	157	158	160	162	163	165	167	168	170	171
	72° WB	HIGH SIDE	190	207	224	241	258	275	297	318	340	361	387	413	438	464
WA4S* WL4S*	75° DB	LOW SIDE	122	124	125	127	129	131	131	132	133	134	135	137	139	141
	62° WB	HIGH SIDE	184	201	218	236	254	272	291	312	335	359	381	407	435	463
	80° DB	LOW SIDE	132	134	136	138	140	142	145	146	147	148	149	150	151	152
	67° WB	HIGH SIDE	185	203	221	239	257	275	298	317	339	362	384	410	438	467
	85° DB	LOW SIDE	145	147	149	152	154	156	156	157	158	159	161	163	164	165
	72° WB	HIGH SIDE	187	205	223	241	259	278	307	319	343	369	390	415	443	472
WA5S* WL5S*	75° DB	LOW SIDE	123	125	127	129	131	133	134	135	136	137	139	141	143	145
	62° WB	HIGH SIDE	187	207	226	245	263	282	305	328	350	373	399	425	451	477
	80° DB	LOW SIDE	134	136	138	139	141	143	145	147	149	151	153	155	156	158
	67° WB	HIGH SIDE	192	211	230	248	267	286	308	331	353	375	402	429	456	483
	85° DB	LOW SIDE	146	148	149	151	152	154	156	159	161	163	165	166	168	169
	72° WB	HIGH SIDE	200	217	235	252	270	287	311	335	358	382	408	434	460	486

Low side pressure ± 4 psig
High side pressure ± 10 psig

TROUBLESHOOTING GE ECM™ MOTORS

CAUTION:

Disconnect power from unit before removing or replacing connectors, or servicing motor. To avoid electric shock from the motor's capacitors, disconnect power and wait at least 5 minutes before opening motor.

Symptom

Motor rocks slightly when starting

Cause/Procedure

- This is normal start-up for ECM

Motor won't start
• No movement

- Check blower turns by hand
- Check power at motor
- Check low voltage (24 Vac R to C) at motor
- Check low voltage connections (G, Y, W, R, C) at motor
- Check for unseated pins in connectors on motor harness
- Test with a temporary jumper between R - G
- Check motor for tight shaft
- Perform motor/control replacement check
- **Perform Moisture Check**

• Motor rocks, but won't start

- Check for loose or compliant motor mount
- Make sure blower wheel is tight on shaft
- Perform motor/control replacement check

Motor oscillates up & down while being tested off of blower

- It is normal for motor to oscillate with no load on shaft

Motor starts, but runs erratically
• Varies up and down or intermittent

- Check line voltage for variation or "sag"
- Check low voltage connections (G, Y, W, R, C) at motor, unseated pins in motor harness connectors
- Check "Bk" for erratic CFM command (in variable-speed applications)
- Check out system controls, Thermostat
- **Perform Moisture Check**

• "Hunts" or "puffs" at high CFM (speed)

- Does removing panel or filter reduce "puffing"?
- Reduce restriction
- Reduce max airflow

• Stays at low CFM despite system call for cool or heat CFM

- Check low voltage (Thermostat) wires and connections
- Verify fan is not in delay mode; wait until delay complete
- "R" missing/not connected at motor
- Perform motor/control replacement check

• Stays at high CFM

- "R" missing/not connected at motor
- Is fan in delay mode? - wait until delay time complete
- Perform motor/control replacement check

• Blower won't shut off

- Current leakage from controls into G, Y or W? Check for Triac switched thermostat or solid-state relay

Excessive noise

• Air noise

- Determine if it's air noise, cabinet, duct or motor noise; interview customer, if necessary
- High static creating high blower speed?
- Is airflow set properly?
- Does removing filter cause blower to slow down? Check filter
- Use low-pressure drop filter
- Check/correct duct restrictions

Symptom

• Noisy blower or cabinet

Cause/Procedure

- Check for loose blower housing, panels, etc.
- High static creating high blower speed?
- Check for air whistling through seams in ducts, cabinets or panels
- Check for cabinet/duct deformation

• "Hunts" or "puffs" at high CFM (speed)

- Does removing panel or filter reduce "puffing"?
- Reduce restriction
- Reduce max. airflow

Evidence of Moisture

• Motor failure or malfunction has occurred and moisture is present

- Replace motor and **Perform Moisture Check**

• Evidence of moisture present inside air mover

- **Perform Moisture Check**

Do

- Check out motor, controls, wiring and connections thoroughly before replacing motor
- Orient connectors down so water can't get in
- Install "drip loops"
- Use authorized motor and model #'s for replacement
- Keep static pressure to a minimum:
- Recommend high efficiency, low static filters
- Recommend keeping filters clean.
- Design ductwork for min. static, max. comfort
- Look for and recommend ductwork improvement, where necessary

Don't

- Automatically assume the motor is bad.
- Locate connectors above 7 and 4 o'clock positions
- Replace one motor or control model # with another (unless an authorized replacement)
- Use high pressure drop filters some have 1/2" H2O drop!
- Use restricted returns

• Size the equipment wisely

- Oversize system, then compensate with low airflow

• Check orientation before inserting motor connectors

- Plug in power connector backwards
- Force plugs

Moisture Check

- Connectors are oriented "down" (or as recommended by equipment manufacturer)
- Arrange harness with "drip loop" under motor
- Is condensate drain plugged?
- Check for low airflow (too much latent capacity)
- Check for undercharged condition
- Check and plug leaks in return ducts, cabinet

Comfort Check

- Check proper airflow settings
- Low static pressure for lowest noise
- Set low continuous-fan CFM
- Use humidistat and 2-speed cooling units
- Use zoning controls designed for ECM that regulate CFM
- Thermostat in bad location?

TROUBLESHOOTING GE ECM™ MOTORS CONT'D.

Replacing ECM Control Module

To replace the control module for the GE variable-speed indoor blower motor you need to take the following steps:

1. You **MUST** have the correct replacement module. The controls are factory programmed for specific operating modes. Even though they look alike, different modules may have completely different functionality.

USING THE WRONG CONTROL MODULE VOIDS ALL PRODUCT WARRANTIES AND MAY PRODUCE UNEXPECTED RESULTS.

2. Begin by removing AC power from the furnace or air handler being serviced. **DO NOT WORK ON THE MOTOR WITH AC POWER APPLIED.** To avoid electric shock from the motor's capacitors, disconnect power and wait at least 5 minutes before opening motor.

3. It is usually not necessary to remove the motor from the blower assembly. However, it is recommended that the whole blower assembly, with the motor, be removed from the furnace/air handler. (Follow the manufacturer's procedures). Unplug the two cable connectors to the motor. There are latches on each connector. **DO NOT PULL ON THE WIRES.** The plugs remove easily when properly released.

4. Locate the two standard ¼" hex head bolts at the rear of the control housing (at the back end of the control opposite the shaft end). Refer to Figure 9. Remove these two bolts from the motor and control assembly while holding the motor in a way that will prevent the motor or control from falling when the bolts are removed. If an ECM2.0 control is being replaced (recognized by an aluminum casting rather than a deep-drawn black steel can housing the electronics), remove only the hex-head bolts. **DO NOT REMOVE THE TORX-HEAD SCREWS.**

5. The control module is now free of mechanical attachment to the motor endshield but is still connected by a plug and three wires inside the control. Carefully rotate the control to gain access to the plug at the control end of the wires. With thumb and forefinger, reach the latch holding the plug to the control and release it by squeezing the latch tab and the opposite side of the connector plug and gently pulling the plug out of the connector socket in the control. **DO NOT PULL ON THE WIRES. GRIP THE PLUG ONLY.**

6. The control module is now completely detached from the motor. Verify with a standard ohmmeter that the resistance from each motor lead (in the motor plug just removed) to the motor shell is >100K ohms. Refer to Figure 10. (Measure to unpainted motor end plate.) If any motor lead fails this test, do not proceed to install the control module. **THE MOTOR IS DEFECTIVE AND MUST BE REPLACED.** Installing the new control module will cause it to fail also.

7. Verify that the replacement control is correct for your application. Refer to the manufacturer's authorized replacement list. **USING THE WRONG CONTROL WILL RESULT IN IMPROPER OR NO BLOWER OPERATION.** Orient the control module so that the 3-wire motor plug can be inserted into the socket in the control. Carefully insert the plug and press it into the socket until it latches. **A SLIGHT CLICK WILL BE HEARD WHEN PROPERLY INSERTED.** Finish installing the replacement control per one of the three following paragraphs, 8a, 8b or 8c.

8a. **IF REPLACING AN ECM 2.0 CONTROL** (control in cast aluminum can with air vents on the back of the can) **WITH AN ECM 2.3 CONTROL** (control containing black potting for water protection in black deep-drawn steel case with no vents in the bottom of the can), locate the two through-bolts and plastic tab that are packed with the replacement control. Insert the plastic tab into the slot at the perimeter of the open end of the can so that the pin is located on the inside of the perimeter of the can. Rotate the can so that the tab inserts into the tab locator hole in the endshield of the motor. Using the two through-bolts provided with the replacement control, reattach the can to the motor.

THE TWO THROUGH-BOLTS PROVIDED WITH THE REPLACEMENT ECM 2.3 CONTROL ARE SHORTER THAN THE BOLTS ORIGINALLY REMOVED FROM THE ECM 2.0 CONTROL AND MUST BE USED IF SECURE ATTACHMENT OF THE CONTROL TO THE MOTOR IS TO BE ACHIEVED. DO NOT OVERTIGHTEN THE BOLTS.

8b. **IF REPLACING AN ECM 2.3 CONTROL WITH AN ECM 2.3 CONTROL**, the plastic tab and shorter through-bolts are not needed. The control can be oriented in two positions 180° apart. **MAKE SURE THE ORIENTATION YOU SELECT FOR REPLACING THE CONTROL ASSURES THE CONTROL'S CABLE CONNECTORS WILL BE LOCATED DOWNWARD IN THE APPLICATION SO THAT WATER CANNOT RUN DOWN THE CABLES AND INTO THE CONTROL.** Simply orient the new control to the motor's endshield, insert bolts, and tighten. **DO NOT OVERTIGHTEN THE BOLTS.**

8c. **IF REPLACING AN ECM 2.0 CONTROL WITH AN ECM 2.0 CONTROL** (It is recommended that ECM 2.3 controls be used for all replacements), the new control must be attached to the motor using through bolts identical to those removed with the original control. **DO NOT OVERTIGHTEN THE BOLTS.**

9. Reinstall the blower/motor assembly into the HVAC equipment. Follow the manufacturer's suggested procedures.

10. Plug the 16-pin control plug into the motor. The plug is keyed. Make sure the connector is properly seated and latched.

11. Plug the 5-pin power connector into the motor. Even though the plug is keyed, **OBSERVE THE PROPER ORIENTATION. DO NOT FORCE THE CONNECTOR.** It plugs in very easily when properly oriented. **REVERSING THIS PLUG WILL CAUSE IMMEDIATE FAILURE OF THE CONTROL MODULE.**

12. Final installation check. Make sure the motor is installed as follows:
- Unit is as far INTO the blower housing as possible.
 - Belly bands are not on the control module or covering vent holes.
 - Motor connectors should be oriented between the 4 o'clock and 8 o'clock positions when the blower is positioned in its final location and orientation.
 - Add a drip loop to the cables so that water cannot enter the motor by draining down the cables. Refer to Figure 11.

The installation is now complete. Reapply the AC power to the HVAC equipment and verify that the new motor control module is working properly. Follow the manufacturer's procedures for disposition of the old control module.

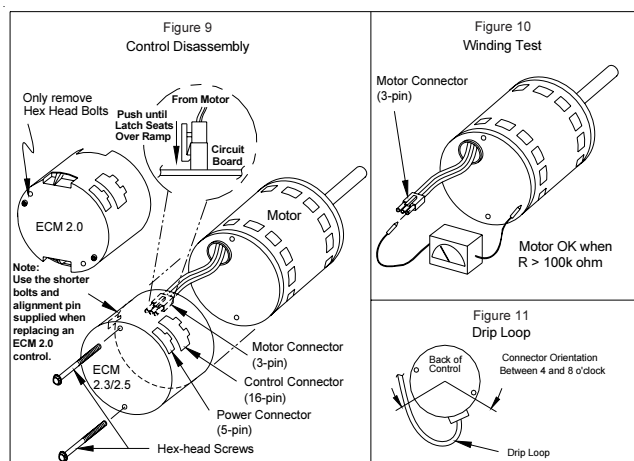

**TABLE 9
INDOOR BLOWER PERFORMANCE ①**

Model	Rated ESP	MAX ESP	② Continuous CFM	③ Rated 1st Stage CFM	④ Rated 2nd Stage CFM	⑤ 5-10 KW CFM	⑥ 15-20 KW CFM
WA/L3S*	0.15	0.80	800	800	1100	1100	1400
WA/L4S*	0.20	0.80	825	1100	1500	1100	1500
WA/L5S*	0.20	0.80	850	1300	1700	1100	1500

- ① Motor will deliver consistent CFM through voltage supply range with no deterioration.
(197-253V for 230/208V models, 414-506V for 460V models)
- ② Continuous CFM is the total air being circulated during continuous (manual) fan mode.
- ③ Will occur automatically with a call for "Y1" signal from thermostat.
- ④ Will occur automatically with a call for "Y2" signal from thermostat.
- ⑤ Will occur automatically with a call for "W1" signal from thermostat.
- ⑥ Will occur automatically with a call for "W2" or "Emergency Heat" signal from thermostat.

**TABLE 10
MAXIMUM ESP OF OPERATION
ELECTRIC HEAT ONLY**

KW-Heat	WA/L3S*	WA/L4S*	WA/L5S*
-A05	.80	.80	.80
-A08	.80	.80	.80
-A10	.80	.80	.80
-A15	.80	.80	.80
-A20	.80	.80	.80
-B06	.80	.80	.80
-B09	.80	.80	.80
-B12	.80	.80	.80
-B15	.80	.80	.80
-B18	.80	.80	.80
-C06	.80	.80	.80
-C09	.80	.80	.80
-C12	.80	.80	.80
-C15	.80	.80	.80
-C18	.80	.80	.80

**TABLE 11
OPTIONAL ACCESSORIES**

MODEL	DESCRIPTION	WA3S3-A	WA3S3-B	WA3S3-C	WA4S3-A	WA4S3-B	WA4S3-C	WA5S3-A	WA5S3-B	WA5S3-C
EHWA4S-A05	Heater Package	X			X					
EHWA4S-A10	Heater Package	X			X					
EHWA4S-A15	Heater Package	X			X					
EHWA4S-A20	Heater Package	X			X					
EHWA5S-A05	Heater Package							X		
EHWA5S-A08	Heater Package	X			X			X		
EHWA5S-A10	Heater Package							X		
EHWA5S-A15	Heater Package							X		
EHWA5S-A20	Heater Package							X		
EHWA3S-B06	Heater Package		X							
EHWA5S-B06	Heater Package					X			X	
EHWA5S-B09	Heater Package		X			X			X	
EHWA5S-B15	Heater Package		X			X			X	
EHWA5S-C06	Heater Package			X			X			X
EHWA5S-C09	Heater Package			X			X			X
EHWA5S-C15	Heater Package			X			X			X
BOP-5	Blank Off Plate (Standard)	X	X	X	X	X	X	X	X	X
CRVMP-5	Classroom Ventilator with Exhaust (3-Position)	X	X	X	X	X	X	X	X	X
EIFM-5C	Economizer with Exhaust	X	X	X	X	X	X	X	X	X
WERV-A5B	Energy Recovery Ventilator	X	X		X	X		X	X	
WERV-C5B	Energy Recovery Ventilator			X			X			X

**TABLE 12
OPTIONAL ACCESSORIES**

MODEL	DESCRIPTION	WL3S2-A	WL3S2-B	WL3S2-C	WL4S2-A	WL4S2-B	WL4S2-C	WL5S2-A	WL5S2-B	WL5S2-C
EHWA4S-A05L	Heater Package	X			X					
EHWA4S-A10L	Heater Package	X			X					
EHWA4S-A15L	Heater Package	X			X					
EHWA4S-A20L	Heater Package	X			X					
EHWA5S-A05L	Heater Package							X		
EHWA5S-A08L	Heater Package	X			X			X		
EHWA5S-A10L	Heater Package							X		
EHWA5S-A15L	Heater Package							X		
EHWA5S-A20L	Heater Package							X		
EHWA3S-B06L	Heater Package		X							
EHWA5S-B06L	Heater Package					X			X	
EHWA5S-B09L	Heater Package		X			X			X	
EHWA5S-B15L	Heater Package		X			X			X	
EHWA5S-C06L	Heater Package			X			X			X
EHWA5S-C09L	Heater Package			X			X			X
EHWA5S-C15L	Heater Package			X			X			X
BOP-5	Blank Off Plate (Standard)	X	X	X	X	X	X	X	X	X
CRVMP-5	Classroom Ventilator with Exhaust (3-Position)	X	X	X	X	X	X	X	X	X
EIFM-5C	Economizer with Exhaust	X	X	X	X	X	X	X	X	X
WERV-A5B	Energy Recovery Ventilator	X	X		X	X		X	X	
WERV-C5B	Energy Recovery Ventilator			X			X			X