

---

# INSTALLATION INSTRUCTIONS

---

## Electric Heat Packages

### Models:

EHWL018A-A05	EHWL030A-B09
EHWL018A-A10	EHWL030A-B15
EHWL024A-A05	EHWL030B-B15
EHWL024A-B05	EHWL030A-C09
EHWL024A-C05	EHWL030A-C15
EHWL030A-A05	EHWL036A-A15
EHWL030A-A10	EHWL036A-B05
EHWL030A-A15	EHWL036A-B15
	EHWL036A-C09
	EHWL036A-C15

For Use with W\*\*LY and W\*\*LF  
Wall-Mounted Air Conditioners



*Climate Control Solutions*

Bard Manufacturing Company, Inc.  
Bryan, Ohio 43506  
[www.bardhvac.com](http://www.bardhvac.com)

Manual: 2100-783B  
Supersedes: 2100-783A  
Date: 4-28-25

# CONTENTS

---

<b>General Information .....</b>	<b>3</b>
Description of Equipment .....	3
Important.....	3
Shipping Damage .....	3
Unpacking Electric Heat Package.....	3
Wiring Main Power.....	4

## Figures

Figure 1	Electrical Connections.....	4
Figure 2	Electric Heat Access Panel and Control Panel Cover Locations.....	6
Figure 3	Screw Mounting Holes .....	8
Figure 4	A through D .....	9
Figure 4E	Installing Heater Package with Two Heat Strips .....	10
Figure 4F	Installing Heater Package with Two Heat Strips .....	11
Figure 4G	Installing Heater Package with Two Heat Strips .....	12
Figure 4H	Installing Heater Package with Two Heat Strips .....	13
Figure 5	Installing Heater Base and Connecting Wiring .....	14
Figure 6	Serial Plate Showing Approved Heater Packages.....	15

<b>Installation .....</b>	<b>5</b>
Installation of Heater Package .....	5

## Tables

Table 1	Electrical Data and BTU Output.....	3
Table 2	References to Figures 3 and 4 by Model Number .....	7

# GENERAL INFORMATION

## Description

The EHW series electric heater packages are field-installable heater packages suitable for use with Bard wall mount air conditioners. The packages consist of the electric heat strip, the heater control base (which includes the heat contactors and circuit breaker or toggle or rotary disconnects), installation instructions and wiring diagrams. See Table 1 for nominal electrical data and BTU output. **Before installation, check unit serial plate to ensure the heater package model to be installed is a listed heater package that is suitable for use with the Bard wall mount unit** (see Figure 6 on page 15).

## Important

The equipment covered in this manual is to be installed by trained, experienced service and installation technicians.

## Shipping Damage

Upon receipt of equipment, the carton should be checked for external signs of shipping damage. If damage is found, the receiving party must contact the last carrier immediately, preferably in writing, requesting inspection by the carrier's agent.

## Unpacking the Electric Heat Package

Remove the heat package from the shipping carton. The heat package must consist of the following:

1. Basic heater.
2. Electric heat control base and wiring.
3. Installation instructions.
4. Two wiring diagrams, one to be applied to unit.
5. Adhesive label to re-mark serial plate to indicate new model number. This is attached to the front of these instructions.

**TABLE 1**  
**Electrical Data and BTU Output**

Heater Package Model	Volts	Phase	Nominal KW	Nominal BTU
EHWL018A-A05	230/208	1	4.6/3.8	15,700/12,800
EHWL018A-A10	230/208	1	9.2/7.5	31,400/25,600
EHWL024A-A05	230/208	1	4.6/3.8	15,700/12,800
EHWL024A-B05	230/208	3	4.6/3.8	15,700/12,800
EHWL024A-C05	460	3	4.6	15,700
EHWL030A-A05	230/208	1	4.6/3.8	15,700/12,800
EHWL030A-A10	230/208	1	9.2/7.5	31,400/25,600
EHWL030A-A15	230/208	1	13.8/11.3	47,100/38,400
EHWL030A-B09	230/208	3	8.3/6.8	28,300/23,000
EHWL030A-B15	230/208	3	13.8/11.3	47,100/38,400
EHWL030B-B15	230/208	3	13.8/11.3	47,100/38,400
EHWL030A-C09	460	3	8.3	28,300
EHWL030A-C15	460	3	13.8	47,100
EHWL036A-A15	230/208	1	13.8/11.3	47,100/38,400
EHWL036A-B05	230/208	3	4.6/3.8	15,700/12,800
EHWL036A-B15	230/208	3	13.8/11.3	47,100/38,400
EHWL036A-C09	460	3	8.3	28,300
EHWL036A-C15	460	3	13.8	47,100

## Wiring Main Power

1. On all installations, size unit power supply wiring for the minimum circuit ampacity requirement for the unit and heater package combination listed on the unit serial plate.

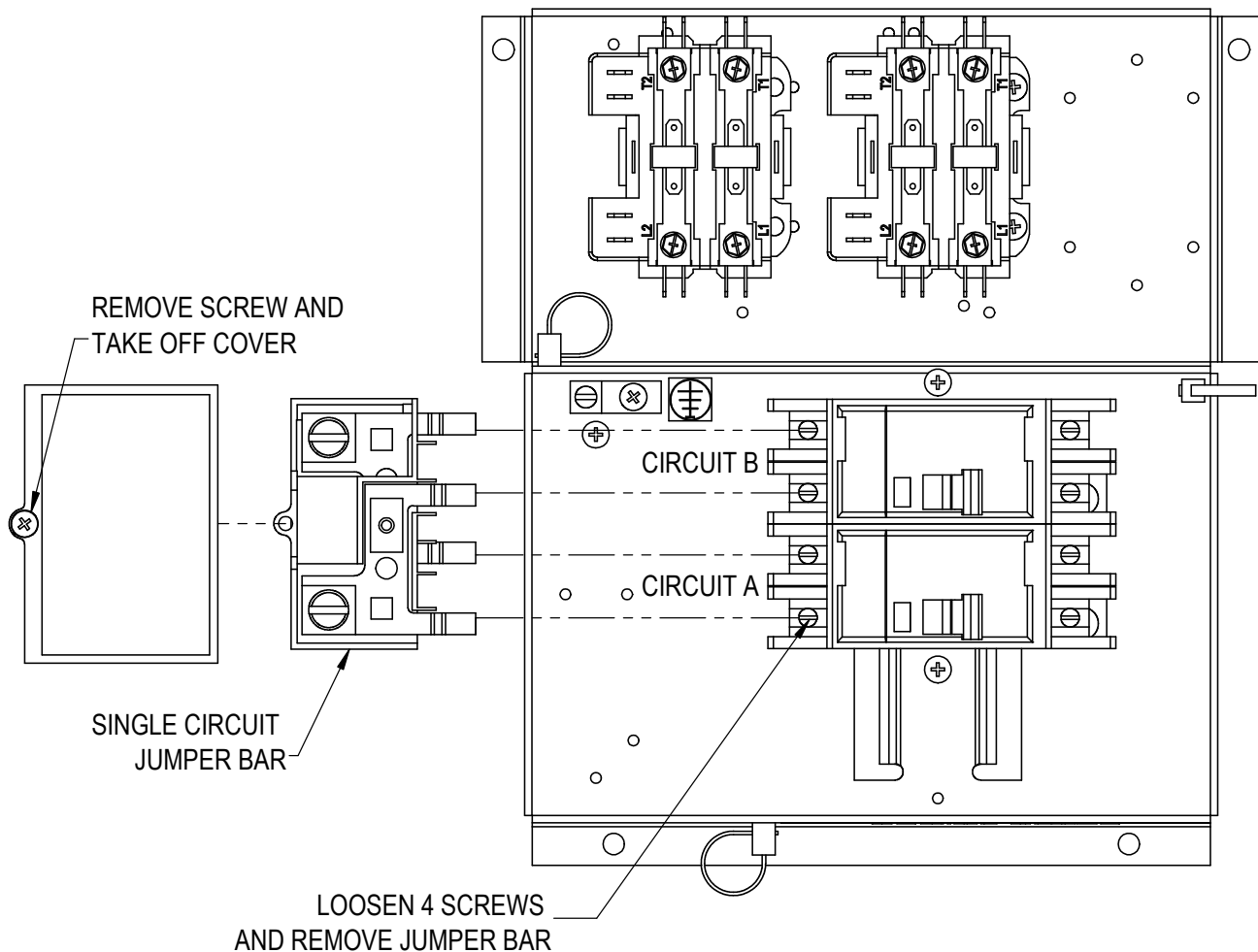
# ⚠ WARNING

**Install properly sized power supply leads for the unit/heater combination minimum circuit ampacity as listed on the unit serial plate. Hazard of fire. Failure to install properly sized conductors could result in fire causing damage, bodily injury or death.**

2. All heater packages covered by this manual are factory wired for single supply circuit. The following heater packages are field-convertible to a dual supply circuit if required or desired:  
EHWL030A-L15, EHWL036A-L15
3. To convert the above heater packages to dual circuit configuration before installation, loosen four (4) screws holding jumper bar in place. Remove jumper bar. Circuits A + B are now identified on the heater package (see Figure 1).

Wire should be sized to the minimum circuit ampacity as specified on the serial plates of units that accept these heater packages for circuits A + B.

**FIGURE 1**  
Electrical Connections



MIS-2907

## Installation of Heater Package

1. Disconnect all power to unit before installation.

### **WARNING**

***Disconnect all power to unit before installing heater package. Hazard of electrical shock. Failure to disconnect power could result in injury or death.***

2. Before installation, check unit serial plate to ensure that the heater package model to be installed is listed as a heater package suitable for use with the unit.

Under no circumstance shall a heater package be installed in a unit if the model number of the heater package does not appear on the unit serial plate.

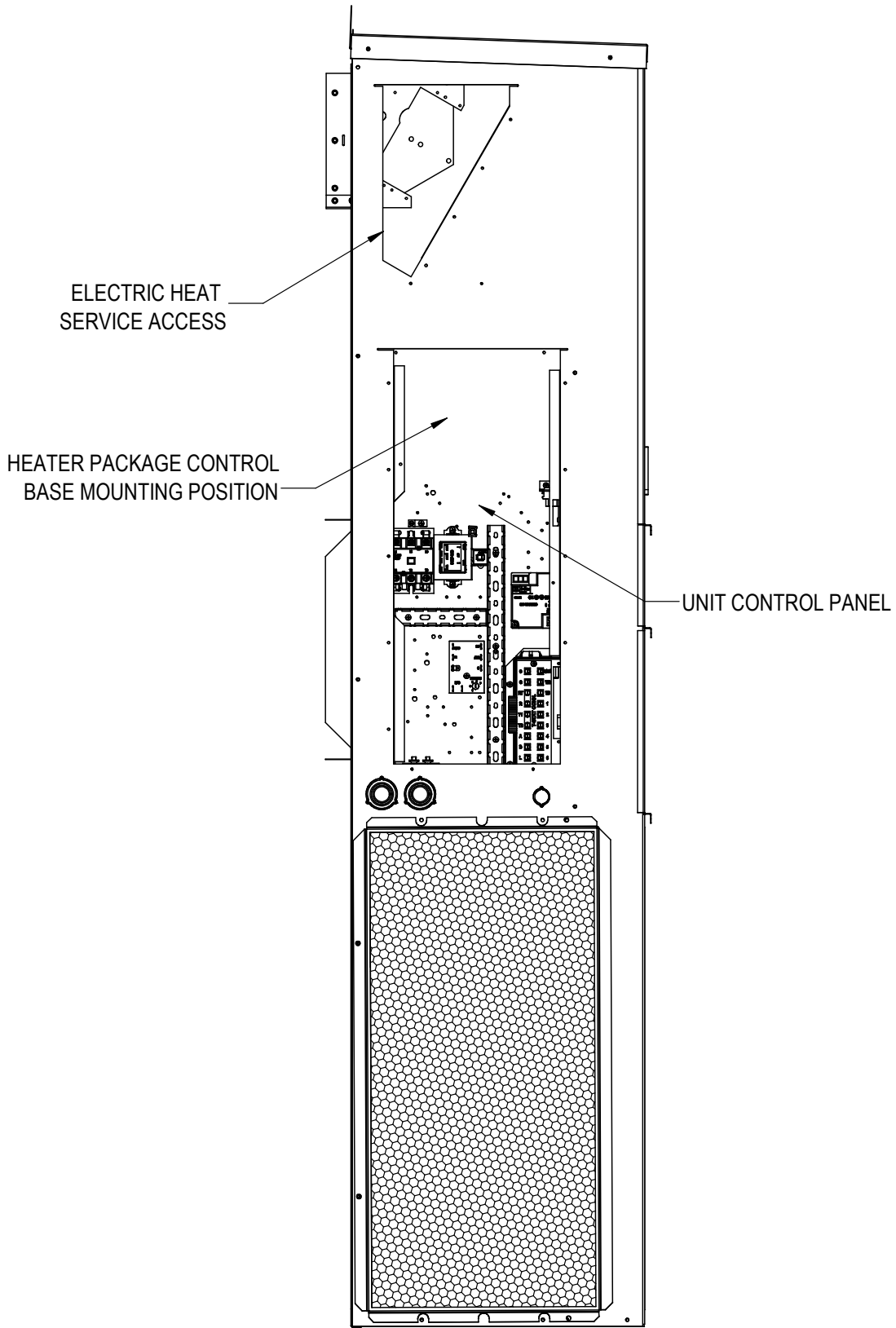
### **WARNING**

***Install only heater packages listed on unit serial plate. Hazard of fire or electrical shock. Failure to install listed heater package could result in fire, injury or death.***

3. Remove electric heater access panel and control panel cover, both inner and outer (see Figure 2).
4. Install heat strip(s) through heater access opening. Position heat strip support rod in heater support hole 1, 2 or 3 as indicated in Table 2 (page 7) and Figure 3 (page 8).
5. Install heater control base into top of control panel as shown in Figure 5 on page 14. Secure with four (4) sheet metal screws provided.
6. Plug male 3-pin connector into mating connector mounted in control panel (see Figure 5).
7. Connect red compressor supply lead to L1 of terminal block. Connect black compressor supply lead to L2 of terminal block. If three phase, connect yellow supply lead to L3 of terminal block. See Figure 5 and wiring diagram.

8. Route wires from heater control base up through raceway in top right corner of control panel to the heaters (see Figure 5).
9. Wire heater package per wiring diagram supplied with this heater package. All wires are stamped with wire numbers that correspond with terminal numbers on the wiring diagram and stamped numbers on the heat strip. Limit switch wires are terminated with insulated quick connect terminals. See Figure 5.
10. Attach adhesive wiring diagram directly above unit wiring diagram on inner control panel cover.
11. Recheck all wiring. Break out appropriate circuit breaker tabs on inner control panel cover to allow trip lever to protrude. Replace control panel and heater access panels.
12. Resupply power to the unit and check for proper operation.
13. Re-mark serial plate with self-adhesive label attached to the front of this manual (see Figure 6 on page 15).

**FIGURE 2**  
**Electric Heater Access Panel and Control Panel Cover Locations**

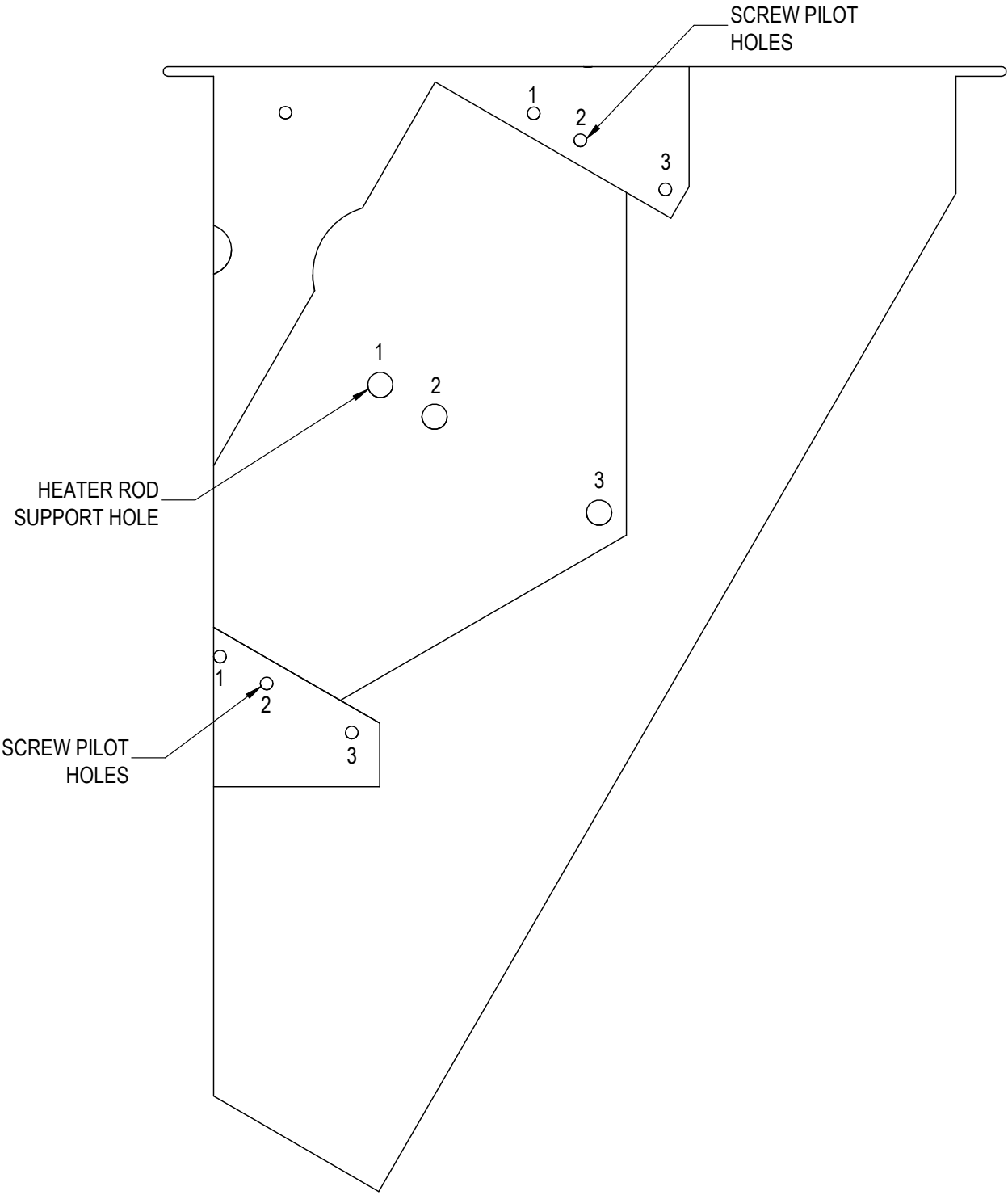


MIS-2906

**TABLE 2**  
**References to Figures 3 and 4 by Model Number**

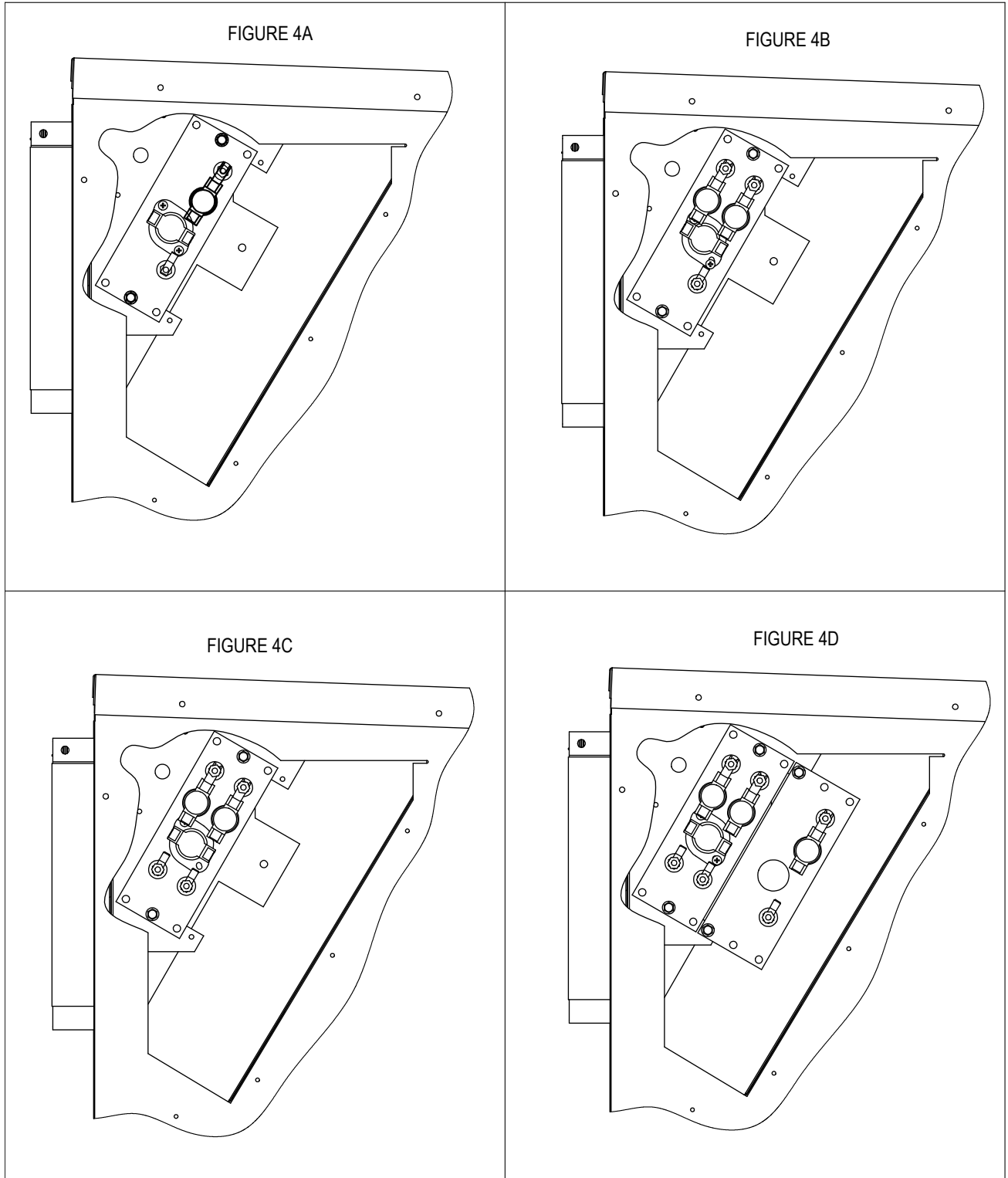
Heater Package Model Number	Figure 3 Rod Support and Screw Mounting Position	Figure 4 Heater Terminal Identification Drawing
EHWL018A-A05	1	4A
EHWL018A-A10	1	4C
EHWL024A-A05	1	4A
EHWL024A-B05	1	4B
EHWL024A-C05	1	4B
EHWL030A-A05	1	4A
EHWL030A-A10	1	4C
EHWL030A-A15	1 + 3	4G
EHWL030A-B09	1	4B
EHWL030A-B15	1 + 3	4H
EHWL030B-B15	1 + 3	4H
EHWL030A-C09	1	4B
EHWL030A-C15	1 + 3	4E
EHWL036A-A15	1 + 3	4F
EHWL036A-B05	1	4B
EHWL036A-B15	1 + 3	4E
EHWL036A-C09	1	4B
EHWL036A-C15	1 + 3	4E

**FIGURE 3**  
**Screw Mounting Holes**



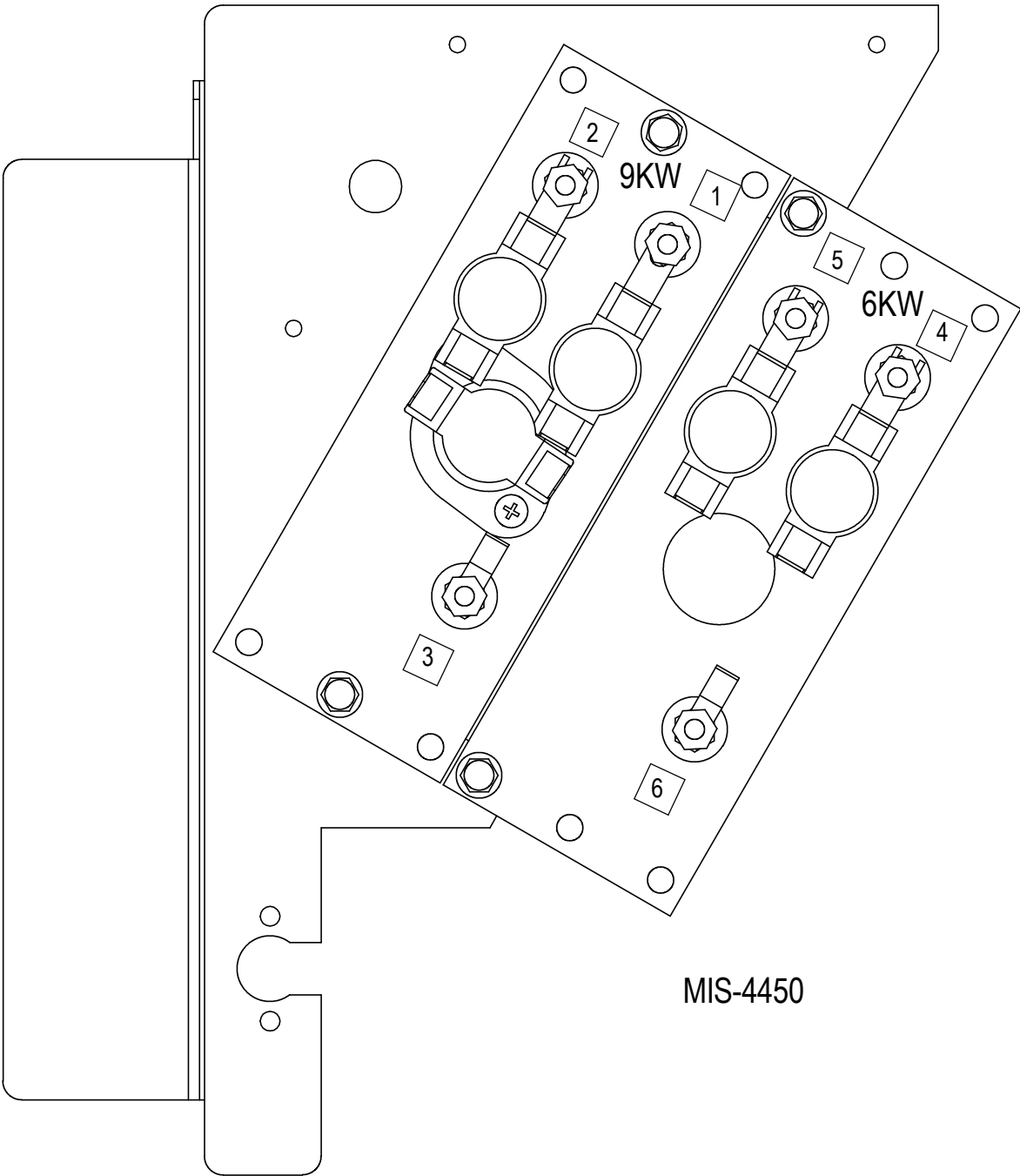
MIS-2905

**FIGURE 4  
A Through D**

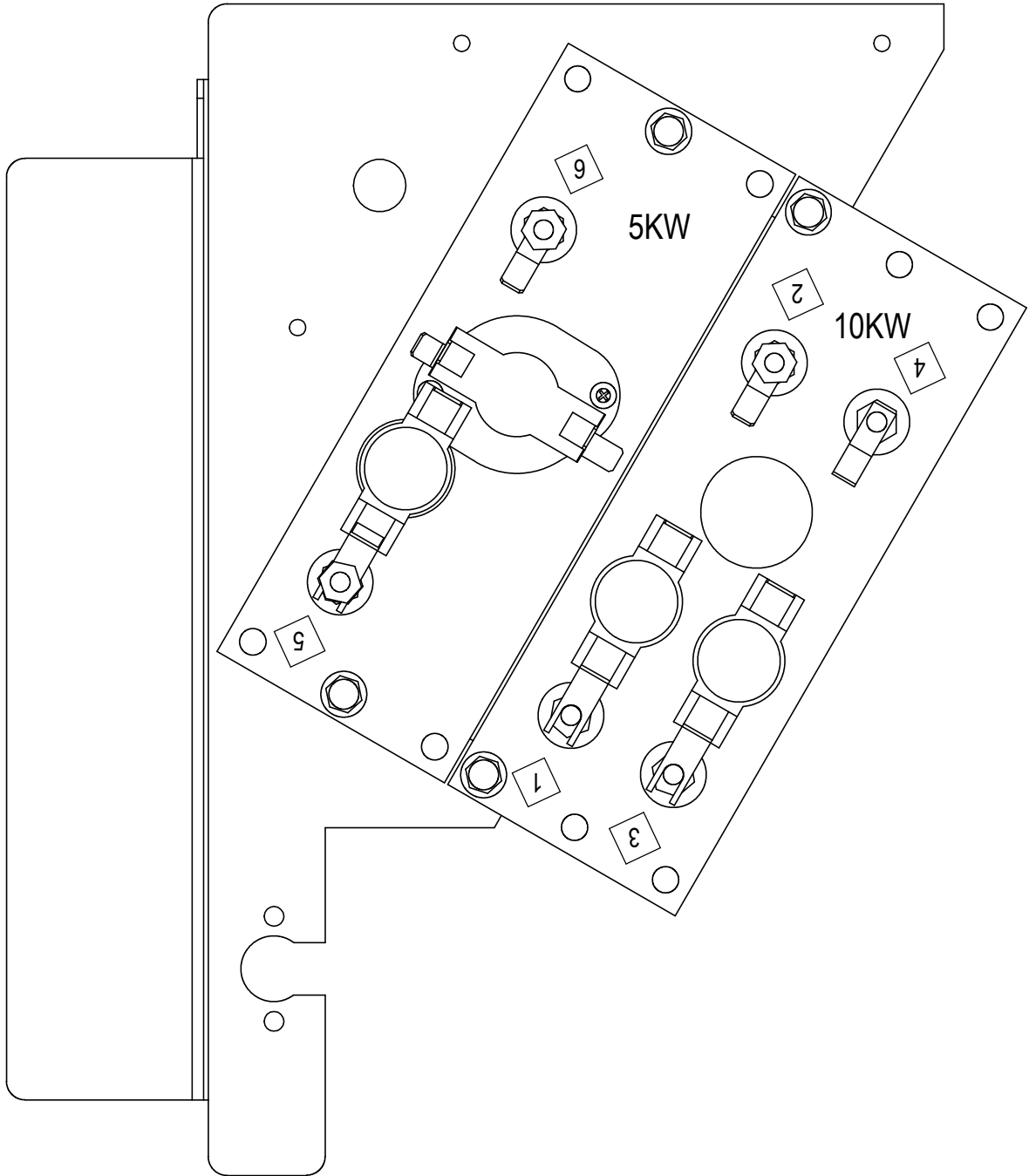


MIS-4449

**FIGURE 4E**  
**Installing Heater Package with Two Heat Strips**

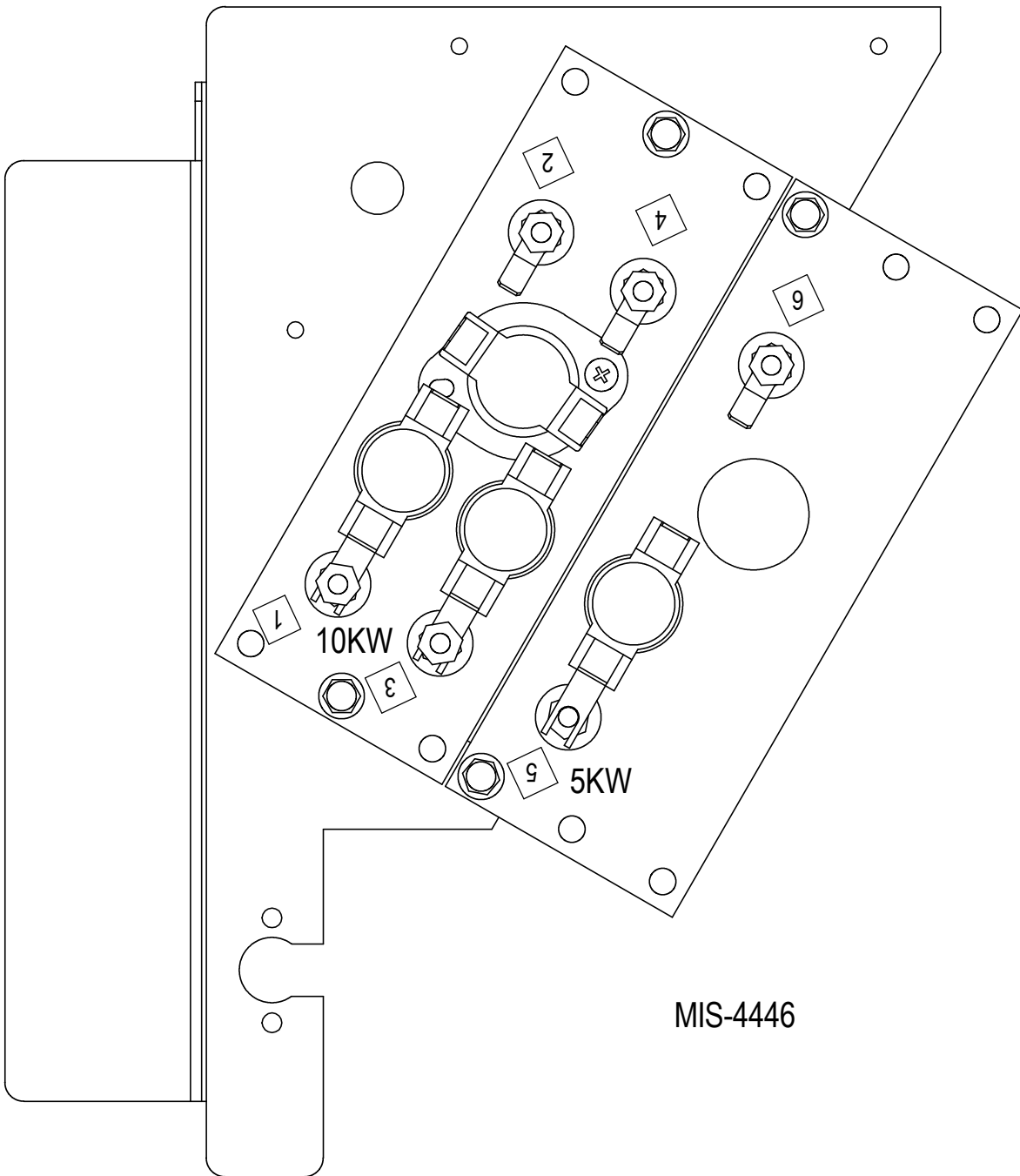


**FIGURE 4F**  
**Installing Heater Package with Two Heat Strips**



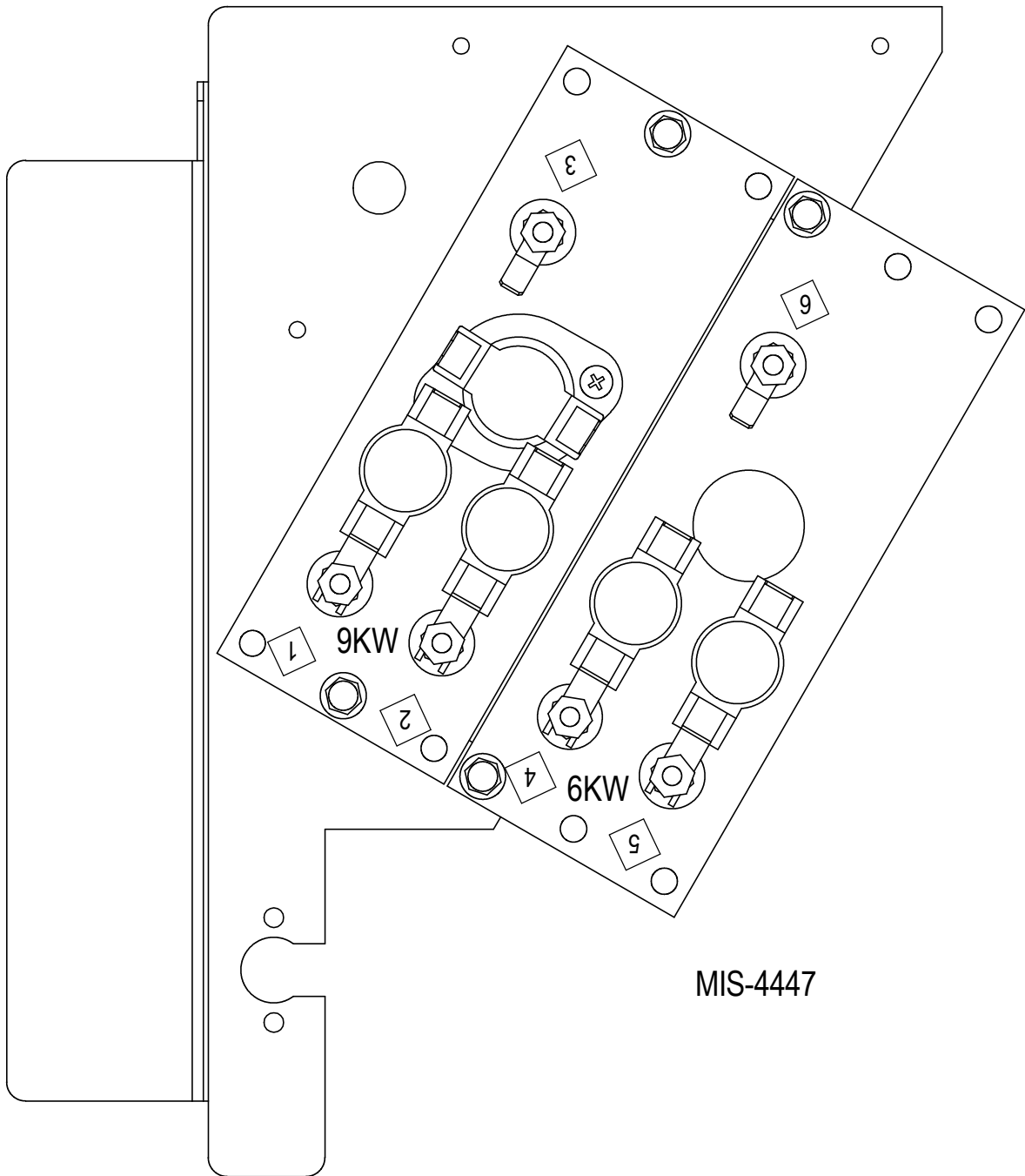
MIS-4445

**FIGURE 4G**  
**Installing Heater Package with Two Heat Strips**



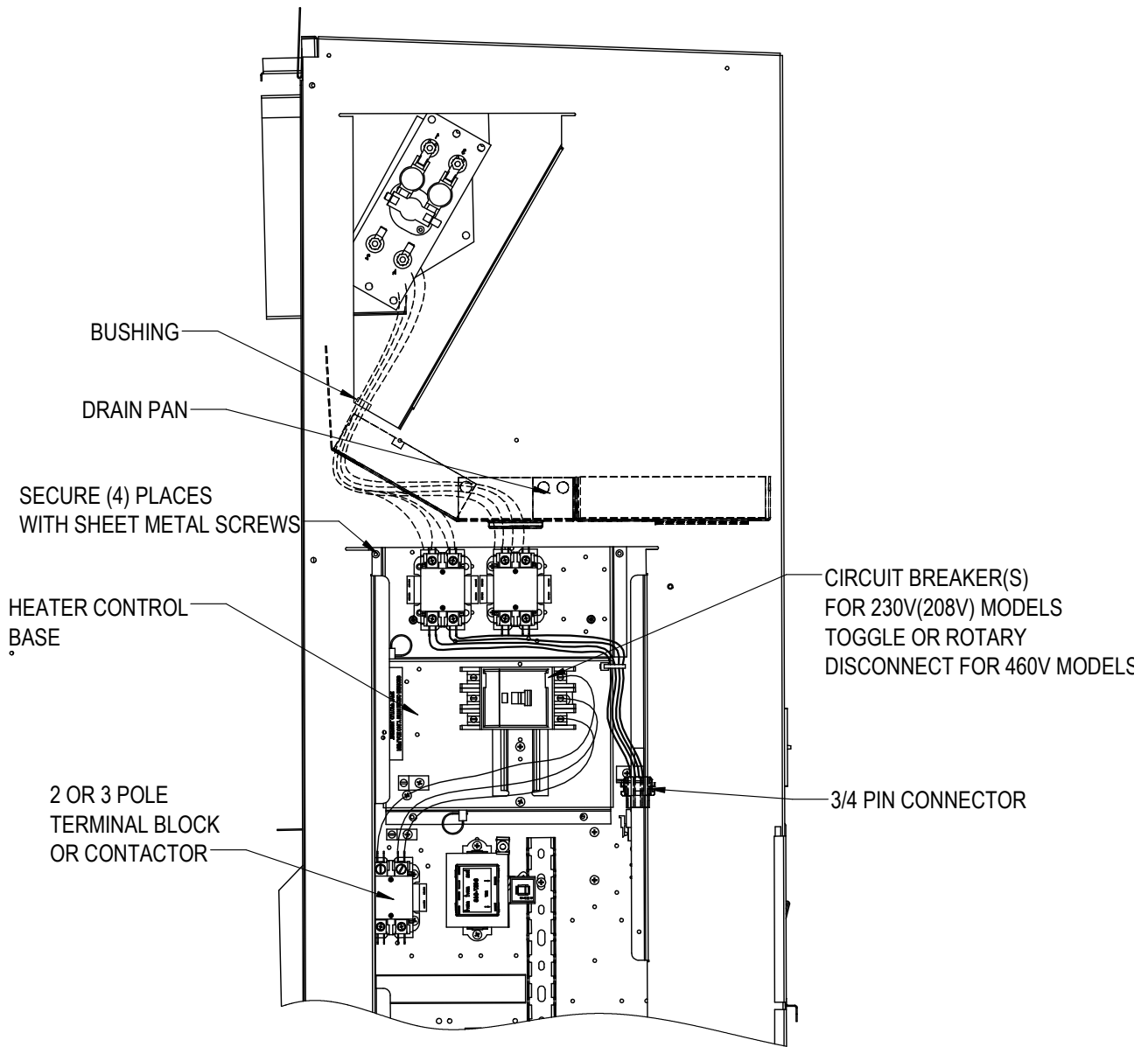
MIS-4446

**FIGURE 4H**  
**Installing Heater Package with Two Heat Strips**



MIS-4447

**FIGURE 5**  
**Installing Heater Base and Connecting Wiring**



MIS-4448

**FIGURE 6**  
**Serial Plate Label Showing Approved Heater Packages**

**BARD MANUFACTURING CO. INC., 1914 RANDOLPH DRIVE**

**(1)**  
**APPROVED**  
**HEATER**

MODEL	PACKAGE	VAC~	HZ	PH
<input type="checkbox"/> C36HY-A00	NONE	230/208	60	1
<input type="checkbox"/> C36HY-A0Z	WMCBC-04A	230/208	60	1
<input checked="" type="checkbox"/> C36HY-A05	EHCH036A-A05	230/208	60	1
<input type="checkbox"/> C36HY-A10	EHCH036A-A10	230/208	60	1
<input type="checkbox"/> C36HY-A15	EHCH036A-A15	230/208	60	1

**SHORT-CIRCUIT CUR**  
**BRANCH CIRCUIT SELECT CURRENT 14.1A OPER**

**SERIAL NUMBER**      XXXXXXXXXXXXXXXX-XX

**SUITABLE FOR PARTIAL OUTDOOR EXPOSURE IN THROUGH THE WALL**  
**ALL MOTORS ARE THERMALLY PROTECTED**

	VAC	HZ	PH	HP	FL
COMPRESSOR	230/208	60	1		
OUTDOOR MOTOR	230/208	60	1	1/3	1.9
INDOOR MOTOR	230/208	60	1	1/2	1.4
ERV	230/208	60	1		2.2 (C
HEATER PACKAGE				KW	FLA
EHCH036A-A05	230/208	60	1	4.6/3.8	20.0/16
EHCH036A-A10	230/208	60	1	9.2/7.5	40.0/3
EHCH036A-A15	230/208	60	1	13.8/11.3	60.0/5

ASSURE THAT SERIAL PLATE IS CLEAN AND DRY, REMOVE APPROPRIATE LABEL STRIP FOR KW REQUIRED AND REMARK SERIAL PLATE AS SHOWN FOR THE HEATER PACKAGE THAT IS INSTALLED

MIS-384 A