

---

# INSTALLATION INSTRUCTIONS

---

## CH Wall Mounted Package 2 Stage Heat Pump

Models:

C24HF-A	C30HF-A
C24HF-B	C30HF-B
C24HF-C	C30HF-C
C24HFDA	C30HFDA
C24HFDB	C30HFDB
C24HFDC	C30HFDC



Bard Manufacturing Company, Inc.  
Bryan, Ohio 43506  
[www.bardhvac.com](http://www.bardhvac.com)

Manual: 2100-830B  
Supersedes: 2100-830A  
Date: 9-18-25

# CONTENTS

---

<b>Safety Instructions .....</b>	<b>4</b>	<b>Start Up .....</b>	<b>28</b>
<b>General Information .....</b>	<b>12</b>	General .....	28
General .....	12	Topping Off System Charge.....	28
Shipping Damage.....	12	Safety Practices .....	28
Additional Publications.....	12	Important Installer Note.....	28
Heat Pump Wall Mount Model Nomenclature .....	13	High Pressure Switch.....	28
Duct Work .....	14	Three Phase Scroll Compressor Start Up	
Filters .....	14	Information.....	29
Fresh Air Intake .....	14	Phase Monitor .....	29
<b>Installation .....</b>	<b>15</b>	Condenser Fan Operation .....	29
Basic Installation Design and Application Planning	15	Sequence of Operation.....	29
Wall Construction .....	15	Cooling Stage 1 .....	29
Outdoor Area Inspection.....	15	Cooling Stage 2.....	29
Condensate Water Drainage .....	15	Heating Stage 1 .....	29
Indoor Ducted and Non-Ducted Applications.....	15	Heating Stage 2 .....	29
Indoor Supply Airflow.....	15	Heating Stage 2 and Electric Heat.....	29
Indoor Return Airflow .....	16	Emergency Heat .....	29
Ducted Applications .....	16	Low Ambient Conditions.....	30
Free Blow Applications.....	16	Defrost Cycle.....	30
Thermostat or Indoor Temperature Sensor		Low Pressure Switch Bypass Operation .....	30
Placement .....	16	High Pressure Switch Operation .....	30
Unit Installation .....	17	Vent Connection Plug.....	31
Materials/Tool List .....	17	Pressure Service Ports .....	31
Wall Preparation.....	17	Service Hints .....	31
Wall Mount Installation to Wall Surface .....	17	<b>Service .....</b>	<b>33</b>
Wiring – Main Power.....	23	Solid State Heat Pump Control Troubleshooting	
Wiring – Low Voltage.....	23	Procedure .....	33
Low Voltage Connections.....	23	Checking Temperature Sensor Outside	
Unit Shutdown Feature .....	23	Unit Circuit.....	34
Dehumidification Feature .....	24	Troubleshooting ECM Indoor Blower Motors.....	35
Ventilation Features .....	24	Refrigerant Leak Detection System (RDS) .....	37
Low Ambient Control (LAC) .....	24	Why RDS? .....	37
Freeze Protection Thermostat.....	24	Sequence of Operation.....	37
Alarm Relay Feature .....	24	Power Up and Self Test.....	37
Dirty Filter Switch Indicator (DFS).....	24	Normal Operation.....	37
Refrigerant Leak Detection System (RDS) .....	24	Alarm State .....	37
		Sensor Fault Mode .....	37
		Mitigation Mode .....	38
		Alarm Reset .....	38
		RDS Diagnosis .....	38
		Sensor End-of-Life.....	38
		Fan Blade Setting Dimensions.....	41
		Removal of Fan Shroud.....	41
		R-454B Refrigerant Charge .....	41
		Unit Airflow .....	45
		Dirty Filter Switch .....	46
		Dirty Filter Switch Adjustment .....	46

**TABLES**

Table 1	Clearance Required for Service Access and Adequate Condenser Airflow.....	18
Table 2	Minimum Clearances Required to Combustible Materials.....	18
Table 3	Field Supplied Controls – Sequence of Operation .....	24
Table 4	Wall Thermostats .....	25
Table 5	Humidity Controls .....	25
Table 6	Thermostat Wire Size.....	25
Table 7	CO <sub>2</sub> Controllers .....	25
Table 8	Troubleshooting .....	33
Table 9	Temperature vs. Resistance.....	34
Table 10	Troubleshooting ECM Indoor Blower Motors .....	36
Table 11	Fan Blade Dimension .....	41
Table 12A	Cooling Pressures – Rated Airflow .....	42
Table 12B	Cooling Pressures – Part Load Airflow... ..	42
Table 13A	Heating Pressures – Rated Airflow .....	43
Table 13B	Heating Pressures – Part Load Airflow ..	43
Table 14	Electrical Specifications .....	44
Table 15	Indoor Airflow Status and Unit Performance.....	45
Table 16	Maximum ESP of Operation – Electric Heat Only .....	48
Table 17	Electric Heat .....	48
Table 18	Optional Accessories .....	48
Table 19	Vent and Control Options .....	49

**FIGURES**

Figure 1	Fresh Air Damper .....	14
Figure 2	Unit Dimensions .....	18
Figure 3	Mounting Instructions – C24H, C30H ...	19
Figure 4	Electric Heat Clearance – All Models.....	20
Figure 5	Wall Mounting Instructions .....	21
Figure 6	Wall Mounting Instructions .....	21
Figure 7	Common Wall Mounting Installations ...	22
Figure 8	Programmable Thermostat Connections .....	26
Figure 9	Non-Programmable Thermostat Connections .....	27
Figure 10	Defrost Control Board .....	32
Figure 11	Control Connector Motor Half .....	36
Figure 12	Refrigerant Leak Detection System .....	37
Figure 13	Sensor Status LED Blink Code.....	38
Figure 14	Refrigerant Leak Detection System (RDS) Troubleshooting .....	39
Figure 15	Refrigerant Leak Detection System (RDS) Wiring Diagram .....	40
Figure 16	Fan Blade Setting .....	41
Figure 17	Dirty Filter Switch Location .....	46
Figure 18	Adjusting Dirty Filter Switch.....	47

**GRAPH**

Graph 1	C24-30H Exhaust Ventilation Delivery... ..	50
---------	--	----

# NOTICE

**APPLIANCE ACCESSIBLE TO THE GENERAL PUBLIC.**

# SAFETY INSTRUCTIONS

---

## READ ALL INSTRUCTIONS BEFORE USE

### Your safety and the safety of others are very important.

We have provided many important safety messages in this manual and on your appliance. Always read and follow all safety messages.

### ANSI Z535.5 Definitions:

**DANGER:** Indicate[s] a hazardous situation which, if not avoided, will result in death or serious injury. The signal word “DANGER” is to be limited to the most extreme situations. DANGER [signs] should not be used for property damage hazards unless personal injury risk appropriate to these levels is also involved.

**WARNING:** Indicate[s] a hazardous situation which, if not avoided, could result in death or serious injury. WARNING [signs] should not be used for property damage hazards unless personal injury risk appropriate to this level is also involved.

**CAUTION:** Indicate[s] a hazardous situation which, if not avoided, could result in minor or moderate injury. CAUTION [signs] without a safety alert symbol may be used to alert against unsafe practices that can result in property damage only.

**NOTICE:** [this header is] preferred to address practices not related to personal injury. The safety alert symbol shall not be used with this signal word. As an alternative to “NOTICE” the word “CAUTION” without the safety alert symbol may be used to indicate a message not related to personal injury.

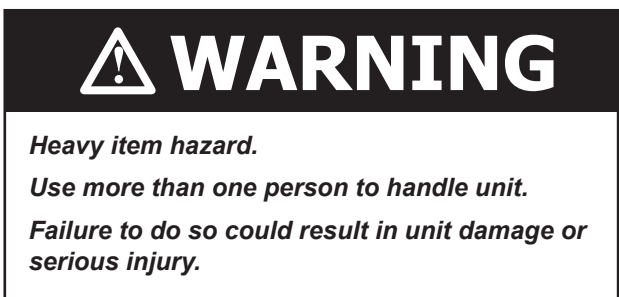
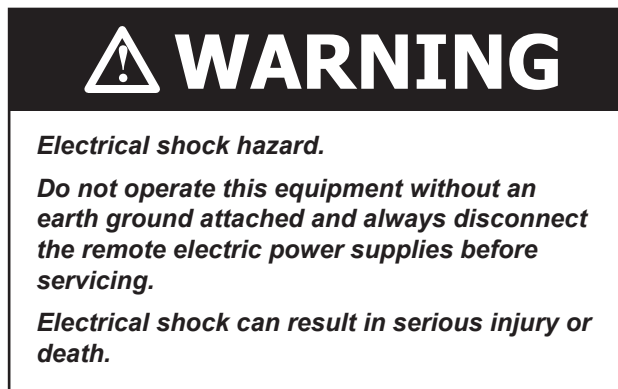
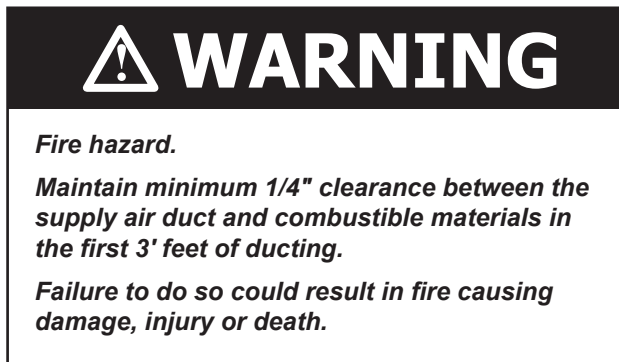

## **WARNING**

**Electrical shock hazard.**

**Have a properly trained individual perform these tasks.**

**Failure to do so could result in electric shock or death.**

## **CAUTION**

**Sharp metallic edges.**

**Take care and wear appropriate protective devices to avoid accidental contact with sharp edges.**

**Failure to do so can result in personal injury.**

## **WARNING**

**Do not use means to accelerate the defrosting process or to clean, other than those recommended by the manufacturer.**

**This appliance shall be stored in a room without continuously operating ignition sources (for example: open flames, an operating gas appliance or an operating electric heater.)**

## **WARNING**

**Do not pierce or burn through copper.**

**Be aware that the refrigerant used in system may not contain an odor.**

**Ducts connected to appliance shall not contain a POTENTIAL IGNITION SOURCE.**

The following symbols are displayed on units.



This symbol indicates that the unit contains a mildly flammable refrigerant.

Refrigerant  
Safety Group  
A2L

This symbol indicates that the refrigerant used is classified as an A2L, or mildly flammable refrigerant.



This symbol indicates that the Operation Manual should be read carefully.



This symbol indicates that a service personnel should be handling this equipment with reference to the Installation Manual.



This symbol indicates that information is available such as the Operation Manual or Installation Manual.

## IMPORTANT SAFETY INSTRUCTIONS



### WARNING

**To reduce the risk of explosion, fire, death, electric shock, scalding or injury to persons when using this product, follow basic precautions, including the following:**

#### GENERAL

- The equipment covered in this manual is to be installed by trained, experienced service and installation technicians.
- This appliance is not intended for use by persons (including children) with reduced physical, sensory or mental capabilities, or lack of experience and knowledge, unless they have been given supervision or instruction concerning use of the appliance by a person responsible for their safety.
- The refrigerant system is completely assembled and charged. All internal wiring is complete.
- The unit is designed for use with or without duct work. Flanges are provided for attaching the supply and return ducts.
- These instructions explain the recommended method to install the air-cooled self-contained unit and the electrical wiring connections to the unit.
- These instructions and any instructions packaged with any separate equipment required to make up the entire air conditioning system should be carefully read before beginning the installation. Note particularly “Starting Procedure” and any tags and/or labels attached to the equipment.
- While these instructions are intended as a general recommended guide, they do not supersede any national and/or local codes in any way. Authorities having jurisdiction should be consulted before the installation is made. See Additional Publications for information on codes and standards.
- Size of unit for a proposed installation should be based on heat loss calculation made according to methods of Air Conditioning Contractors of America (ACCA). The air duct should be installed in accordance with the Standards of the National Fire Protection Association for the Installation of Air Conditioning and Ventilating Systems of Other Than Residence Type, NFPA No. 90A, and Residence Type Warm Air Heating and Air Conditioning Systems, NFPA No. 90B. Where local regulations are at a variance with instructions, installer should adhere to local codes.

#### INSTALLATION

- For appliances intended for use at altitudes exceeding 2,000 meters (6,562 feet), the maximum altitude of use shall be stated.
- Before use, the appliance must be properly installed as described in this manual.
- Contact the authorized service technician for repair or maintenance of this unit.
- Contact the installer for installation of this unit.
- The air conditioner is not intended for use by young children or invalids without supervision.
- Young children should be supervised to ensure that they do not play with the air conditioner.
- Installation work must be performed in accordance with the National Electric Code by qualified and authorized personnel only.
- Connect to a properly rated, protected, and sized power circuit to avoid electrical overload.
- Adhere to all industry recommended safety procedures including the use of long-sleeved gloves and safety glasses.
- Use care when unpacking and installing. The edges of the product may be sharp.
- Keep packaging materials out of the reach of children. These materials can pose a suffocation risk to children.
- Auxiliary devices which may be a POTENTIAL IGNITION SOURCE shall not be installed in the duct work. Examples of such POTENTIAL IGNITION SOURCES are hot surfaces with a temperature exceeding 700°C and electric switching devices.

## IMPORTANT SAFETY INSTRUCTIONS



### WARNING

---

#### OPERATION

- This appliance is not intended for use by persons (including children) with reduced physical, sensory, or mental capabilities, or lack of experience and knowledge, unless they have been given supervision or instruction concerning use of the appliance by a person responsible for their safety.
- Use this appliance only for its intended purpose.
- Never attempt to operate this appliance if it is damaged, malfunctioning, partially disassembled, or has missing or broken parts.
- Do not tamper with controls.
- Keep all required ventilation openings clear of obstructions.
- Ducts connected to an appliance shall not contain a POTENTIAL IGNITION SOURCE.

# INSTRUCTIONS DE SÉCURITÉ

## LIRE TOUTES LES INSTRUCTIONS AVANT UTILISATION

### Votre sécurité et celle des autres sont très importantes.

Nous avons fourni de nombreux messages de sécurité importants dans ce manuel et sur votre appareil. Lisez et suivez toujours tous les messages de sécurité.

### Définitions ANSI Z535.5 :

**DANGER** : Indique une situation dangereuse qui, si elle n'est pas évitée, entraînera certainement la mort ou des blessures graves. Le mot « DANGER » doit être limité aux situations extrêmes. Les indications « DANGER » ne doivent pas être utilisées pour les risques de dégâts matériels, à moins qu'il n'existe un risque concomitant de blessures corporelles.

**AVERTISSEMENT** : Indique une situation dangereuse qui, si elle n'est pas évitée, peut entraîner la mort ou des blessures graves. Les indications « AVERTISSEMENT » ne doivent pas être utilisées pour les risques de dégâts matériels, à moins qu'il n'existe un risque concomitant de blessures corporelles.

**ATTENTION** : Indique une situation dangereuse qui, si elle n'est pas évitée, peut entraîner des blessures mineures à modérées. Les indications « ATTENTION », sans symbole d'avertissement, peuvent être utilisées pour alerter sur des pratiques dangereuses pouvant entraîner des dégâts matériels uniquement.

**REMARQUE** : cet avis concerne les pratiques n'entraînant aucune blessure corporelle. Le symbole d'avertissement ne doit pas être utilisé avec ce mot. Comme alternative à « AVIS », le mot « ATTENTION » sans symbole d'avertissement peut être utilisé pour indiquer un message non lié à des blessures corporelles.



### AVERTISSEMENT

*Risque de choc électrique.*

*Ne pas faire fonctionner cet équipement sans qu'il soit relié à la terre et toujours débrancher les alimentations électriques avant de procéder aux opérations d'entretien.*

*Une électrisation peut entraîner des blessures graves ou la mort.*

### REMARQUE

**APPAREIL ACCESSIBLE AU GRAND PUBLIC.**

### AVERTISSEMENT

*Risque d'incendie.*

*Conserver un dégagement minimal de 6,35 mm/1/4 po entre le conduit d'air soufflé et les matériaux combustibles sur les 900 premiers millimètres (3 pi) du conduit.*

*Le non-respect de cette consigne entraîne des risques de dégâts matériels, de blessures corporelles ou de décès.*

### AVERTISSEMENT

*Risque lié aux objets lourds.*

*Plusieurs personnes sont nécessaires à la manipulation de l'unité.*

*Le non-respect de cette consigne peut entraîner dégâts à l'unité ou des blessures graves.*



## AVERTISSEMENT

*Risque de choc électrique.*

*Ces tâches doivent être réalisées par une personne parfaitement qualifiée et formée.*

*Le non-respect de cette consigne peut entraîner des chocs électriques ou la mort.*



## ATTENTION

*Arêtes métalliques vives.*

*Faites attention et portez des dispositifs de protection appropriés pour éviter tout contact accidentel avec des arêtes vives.*

*Le non-respect de cette consigne peut entraîner des blessures corporelles.*



## AVERTISSEMENT

*N'utilisez pas de moyens pour accélérer le processus de dégivrage ou pour nettoyer, autres que ceux recommandés par le fabricant.*

*Cet appareil doit être entreposé dans une pièce sans sources d'inflammation fonctionnant en continu (par exemple : flammes nues, un appareil à gaz en fonctionnement ou un appareil de chauffage électrique en fonctionnement).*



## AVERTISSEMENT

*Ne percez pas ou ne brûlez pas à travers le cuivre.*

*Sachez que le réfrigérant utilisé dans le système peut ne pas contenir d'odeur.*

*Les conduits raccordés à l'appareillage ne doivent pas contenir de **SOURCE D'INFLAMMATION POTENTIELLE**.*

Les symboles suivants sont affichés sur les unités.



Ce symbole indique que l'unité contient un réfrigérant légèrement inflammable.

Refrigerant  
Safety Group  
A2L

Ce symbole indique que le réfrigérant utilisé est classé comme réfrigérant A2L ou légèrement inflammable.



Ce symbole indique que le manuel d'utilisation doit être lu attentivement.



Ce symbole indique qu'un membre du personnel de service devrait manipuler cet équipement en se référant au manuel d'installation.



Ce symbole indique que des informations sont disponibles telles que le manuel d'utilisation ou le manuel d'installation.

## INSTRUCTIONS DE SÉCURITÉ IMPORTANTES



### AVERTISSEMENT

**Pour réduire le risque d'explosion, d'incendie, de décès, de choc électrique, d'échaudure ou de blessures pour les personnes lors de l'utilisation de ce produit, suivez les précautions de base, notamment les suivantes :**

#### GÉNÉRALITÉS

- L'équipement couvert dans ce manuel doit être installé par des techniciens de service et d'installation formés et expérimentés.
- Cet appareil n'est pas destiné à être utilisé par des personnes (y compris des enfants) ayant des capacités physiques, sensorielles ou mentales réduites, ou un manque d'expérience et de connaissances, à moins qu'elles n'aient reçu la supervision ou l'instruction concernant l'utilisation de l'appareil par une personne responsable de leur sécurité.
- Le système de réfrigérant est complètement assemblé et chargé. Tout le câblage interne est complet.
- L'unité est conçue pour être utilisée avec ou sans conduits. Des brides sont prévues pour fixer les conduits d'alimentation et de retour.
- Ces instructions expliquent la méthode recommandée pour installer l'unité autonome refroidie à l'air et les connexions de câblage électrique à l'unité.
- Ces instructions et toutes les instructions emballées avec tout équipement distinct requis pour constituer l'ensemble du système de climatisation doivent être lues attentivement avant de commencer l'installation. Notez en particulier « Procédure de démarrage » et les étiquettes et / ou étiquettes attachées à l'équipement.
- Bien que ces instructions soient conçues comme un guide général recommandé, elles ne remplacent en aucune façon les codes nationaux et/ou locaux. Les autorités compétentes devraient être consultées avant que l'installation ne soit effectuée. Voir d'autres publications pour obtenir des renseignements sur les codes et les normes.
- La taille de l'unité pour une installation proposée devrait être basée sur le calcul de la perte de chaleur effectué selon les méthodes de Air Conditioning Contractors of America (ACCA). Le conduit d'air devrait être installé conformément aux Normes de la National Fire Protection Association for the Installation of Air Conditioning and Ventilating Systems of Other Than Residence Type, NFPA No. 90A, et aux Systèmes de chauffage et de climatisation d'air chaud de type résidence, NFPA No. 90B. Lorsque les réglementations locales sont en contradiction avec les instructions, l'installateur doit respecter les codes locaux.

#### L'INSTALLATION

- Pour les appareils destinés à être utilisés à des altitudes supérieures à 2 000 mètres (6 562 pieds), l'altitude maximale d'utilisation doit être indiquée.
- Avant utilisation, l'appliance doit être correctement installée comme décrit dans ce manuel.
- Communiquez avec le technicien d'entretien autorisé pour la réparation ou l'entretien de cette unité.
- Contactez le programme d'installation pour l'installation de cet appareil.
- Le climatiseur n'est pas destiné à être utilisé par de jeunes enfants ou des invalides sans surveillance.
- Les jeunes enfants devraient être surveillés pour s'assurer qu'ils ne jouent pas avec le climatiseur.
- Les travaux d'installation doivent être effectués conformément au Code national de l'électricité par du personnel qualifié et autorisé uniquement.
- Connectez-vous à un circuit d'alimentation correctement évalué, protégé et dimensionné pour éviter les surcharges électriques.
- Respectez toutes les procédures de sécurité recommandées par l'industrie, y compris l'utilisation de gants à manches longues et de lunettes de sécurité.
- Faites attention lors du déballage et de l'installation. Les bords du produit peuvent être tranchants.
- Gardez les matériaux d'emballage hors de la portée des enfants. Ces matériaux peuvent poser un risque d'étouffement pour les enfants.
- Les dispositifs auxiliaires qui peuvent être une SOURCE D'INFLAMMATION POTENTIELLE ne doivent pas être installés dans les conduits. Des exemples de telles SOURCES D'INFLAMMATION POTENTIELLES sont les surfaces chaudes dont la température dépasse 700 °C et les dispositifs de commutation électrique.

## INSTRUCTIONS DE SÉCURITÉ IMPORTANTES



### AVERTISSEMENT

---

#### OPÉRATION

- Cet appareil n'est pas destiné à être utilisé par des personnes (y compris des enfants) ayant des capacités physiques, sensorielles ou mentales réduites, ou un manque d'expérience et de connaissances, à moins qu'elles n'aient reçu une supervision ou une instruction concernant l'utilisation de l'appareil par une personne responsable de leur sécurité.
- Utilisez cet appareil uniquement aux fins prévues.
- N'essayez jamais de faire fonctionner cet appareil s'il est endommagé, défectueux, partiellement démonté ou s'il a des pièces manquantes ou cassées.
- Ne pas altérer les contrôles.
- Gardez toutes les ouvertures de ventilation nécessaires à l'écart des obstacles.
- Les conduits raccordés à un appareil ne doivent pas contenir de SOURCE D'INFLAMMATION POTENTIELLE.

# GENERAL INFORMATION

---

## General

The equipment covered in this manual is to be installed by trained, experienced service and installation technicians.

The refrigerant system is completely assembled and charged. All internal wiring is complete.

The unit is designed for use with or without duct work. Flanges are provided for attaching the supply and return ducts.

These instructions explain the recommended method to install the air cooled self-contained unit and the electrical wiring connections to the unit.

These instructions and any instructions packaged with any separate equipment required to make up the entire air conditioning system should be carefully read before beginning the installation. Note particularly "Starting Procedure" and any tags and/or labels attached to the equipment.

While these instructions are intended as a general recommended guide, they do not supersede any national and/or local codes in any way. Authorities having jurisdiction should be consulted before the installation is made. See **Additional Publications** for information on codes and standards.

Size of unit for a proposed installation should be based on heat loss/gain calculation made according to methods of Air Conditioning Contractors of America (ACCA). The air duct should be installed in accordance with the Standards of the National Fire Protection Association for the Installation of Air Conditioning and Ventilating Systems of Other Than Residence Type, NFPA No. 90A, and Residence Type Warm Air Heating and Air Conditioning Systems, NFPA No. 90B. Where local regulations are at a variance with instructions, installer should adhere to local codes.

## Shipping Damage

Upon receipt of equipment, the carton should be checked for external signs of shipping damage. If damage is found, the receiving party must contact the last carrier immediately, preferably in writing, requesting inspection by the carrier's agent.

## Additional Publications

These publications can help when installing the heat pump. They can usually be found at the local library or purchased directly from the publisher. Be sure to consult the current edition of each standard.

National Electrical Code .....ANSI/NFPA 70

Standard for the Installation of Air Conditioning and Ventilating Systems  
.....ANSI/NFPA 90A

Standard for Warm Air Heating and Air Conditioning Systems  
.....ANSI/NFPA 90B

Load Calculation for Winter and Summer Air Conditioning  
..... ACCA Manual J Residential

Duct Design for Residential Winter and Summer Air Conditioning and Equipment Selection  
..... ACCA Manual D

For more information, contact these publishers:

**ACCA**      **Air Conditioning Contractors of America**  
1712 New Hampshire Ave. N.W.  
Washington, DC 20009  
Telephone: (202) 483-9370  
Fax: (202) 234-4721

**ANSI**      **American National Standards Institute**  
11 West Street, 13th Floor  
New York, NY 10036  
Telephone: (212) 642-4900  
Fax: (212) 302-1286

**ASHRAE**    **American Society of Heating, Refrigeration and Air Conditioning Engineers, Inc.**  
1791 Tullie Circle, N.E.  
Atlanta, GA 30329-2305  
Telephone: (404) 636-8400  
Fax: (404) 321-5478

**NFPA**      **National Fire Protection Association**  
Batterymarch Park  
P.O. Box 9101  
Quincy, MA 02269-9901  
Telephone: (800) 344-3555  
Fax: (617) 984-7057

# Heat Pump Wall Mount Model Nomenclature

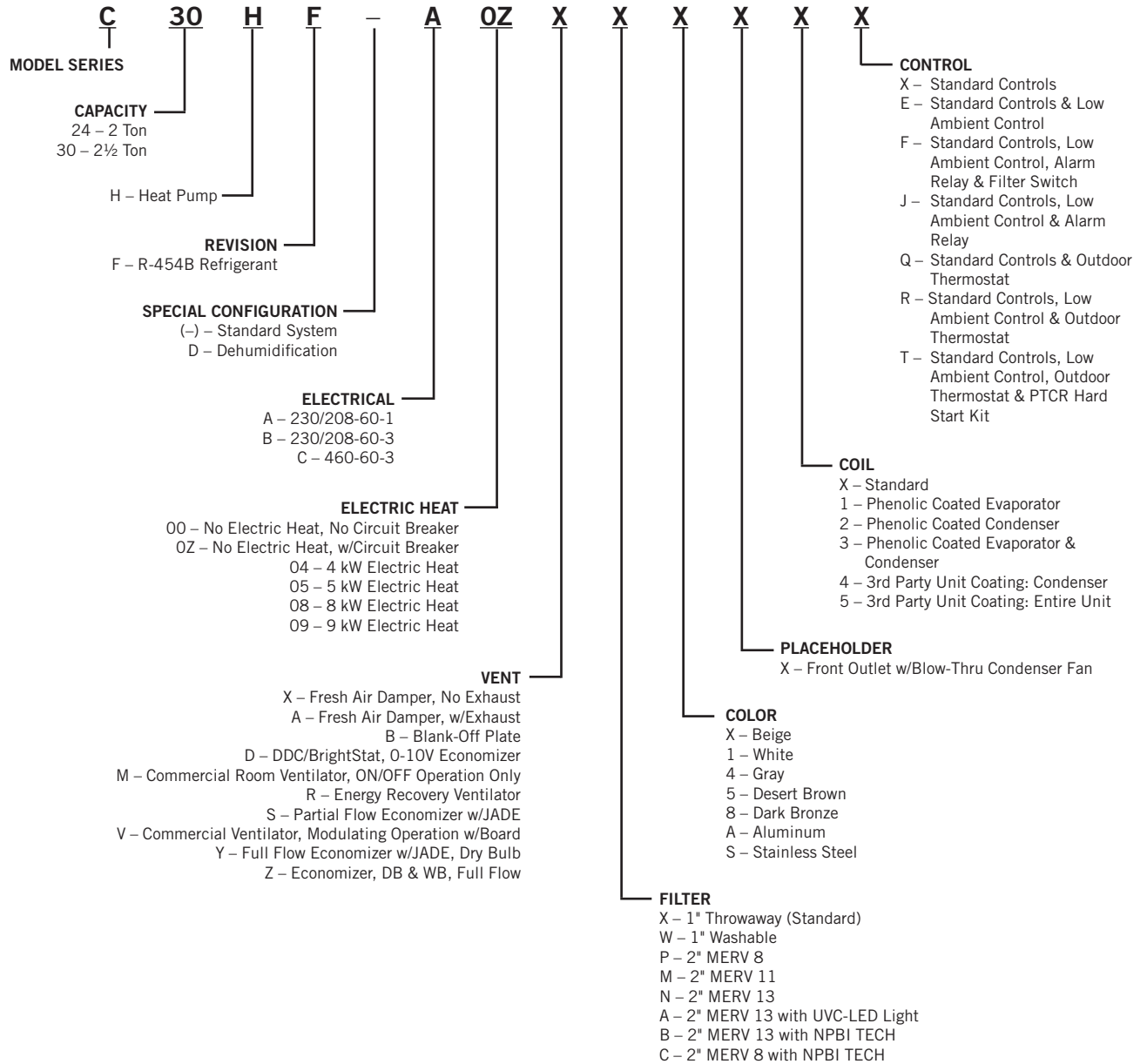

## Duct Work

All duct work, supply and return, must be properly sized for the design airflow requirement of the equipment. Air Conditioning Contractors of America (ACCA) is an excellent guide to proper sizing. All duct work or portions thereof not in the conditioned space should be properly insulated in order to both conserve energy and prevent condensation or moisture damage.

Refer to the Maximum ESP of Operation table on page 48.

Design the duct work according to methods given by the Air Conditioning Contractors of America (ACCA). When duct runs through unheated spaces, it should be insulated with a minimum of 1" of insulation. Use insulation with a vapor barrier on the outside of the insulation. Flexible joints should be used to connect the duct work to the equipment in order to keep the noise transmission to a minimum.

For all models, a 1/4" clearance to combustible material for the first 3' of duct attached to the outlet air frame is required. See **Ducted Applications** on page 16 and Figure 3 (page 19) and Figure 4 (page 20) for further details.

Ducts through the walls must be insulated and all joints taped or sealed to prevent air or moisture entering the wall cavity.

Some installations may not require any return air duct. A metallic return air grille is required with installations not requiring a return air duct. The spacing between louvers on the grille shall not be larger than 5/8".

Any grille that meets with 5/8" louver criteria may be used. It is recommended that Bard Return Air Grille Kit RG-2W through RG-3W or RFG-2W through RFG-3W be installed when no return duct is used. Contact distributor or factory for ordering information. If using a return air filter grille, filters must be of sufficient size to allow a maximum velocity of 400 fpm.

**NOTE:** *If no return air duct is used, applicable installation codes may limit this cabinet to installation only in a single story structure.*

## Filters

A 1" throwaway filter is standard with each unit. The filter slides into position making it easy to service. This filter can be serviced from the outside by removing the filter access panel. A 1" washable filter and 2" pleated filter are also available as optional accessories. The internal filter brackets are adjustable to accommodate the 2" filter by bending two tabs down on each side of the filter support bracket.

## Fresh Air Intake

All units are built with fresh air inlet slots punched in the service door.

If the unit is equipped with a fresh air damper assembly, the assembly is shipped already attached to the unit. The damper blade is pre-set in the #3 position. If more or less fresh air is required, adjust damper pins (see Figure 1). The graph found on page 50 gives approximate fresh air amounts based on the blade position stop location.

All capacity, efficiency and cost of operation information is based upon the fresh air blank-off plate in place and is recommended for maximum energy efficiency.

The blank-off plate is available upon request from the factory and is installed in place of the fresh air damper shipped with each unit.

**FIGURE 1**  
**Fresh Air Damper**

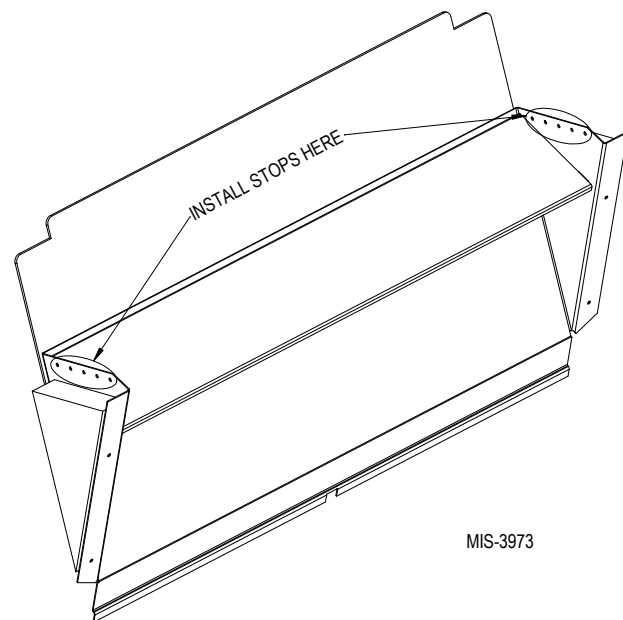

## Basic Installation Design and Application Planning

Successful unit installations require proper planning and site inspection before installation begins. Before installing the wall mount unit, make sure that all service and airflow clearances are met and that the unit can meet all applicable code and regulation requirements. Provide an inspection of both the inside and outside of the structure by reviewing floorplans and/or visiting the installation site.

### Wall Construction

The wall must be inspected to ensure that the weight of the unit can be supported. Be sure to review all applicable construction codes and regulations including seismic requirements. When inspecting wood frame walls, the wall construction must be strong and rigid enough to carry the weight of the unit without transmitting any unit vibration. It is important that the side unit wall mounting lags and optional bottom bracket are supported by structural members inside the wall cavity. Concrete block and brick walls must be thoroughly inspected to ensure that they are capable of carrying the weight of the installed unit. Metal buildings must contain structural components to support the unit weight. If heavily corrugated siding is present, it may need to be trimmed and flashed similar to a window to provide a flat, even surface to attach and seal the unit to the wall. Heavy gauge corrugations that would be present on shipping containers and blast-proof structures may require the installation of a metal plate over the corrugated area. It is important that the unit area is weatherized and sealed to avoid air and water infiltration into the area between the unit and the wall.

### Outdoor Area Inspection

Inspect the outdoor area of the jobsite or review construction plans and locate the area where the wall mount is to be installed. The outdoor area must be free from obstructions including fences, bushes and walls that will hinder unit operation regarding outdoor condenser airflow and unit serviceability. Do not install units in enclosed areas that limit the amount of ambient temperature airflow. Warm air will exit the front condenser section of the unit, and outdoor ambient temperature air must be able to enter side intake condenser openings of the unit. Portable or modular building placement must be in a way that the wall mount units have a constant supply of outdoor air for proper unit operation. Make sure that the service panels of the unit are accessible. Inspect wall surfaces for obstructions that could hinder unit installation and servicing including outdoor electrical conduits, junction boxes, wall drains, vent hoods, windows, doors, overhangs and posts.

**NOTE:** Before mounting the heat pump unit, consideration should be given to the condensate removal from the outdoor coil when in heating mode. The unit must be mounted high enough above grade to ensure that ice will not build up under the unit and come into contact with the base of the unit. If allowed, this could cause damage to the coil and other base components. Also, be sure there are no air obstructions to the sides or front of the unit, such as bushes or fences, that would inhibit condenser airflow.

### Condensate Water Drainage

Review all codes and requirements for unit condensate drainage. A clear, flexible PVC drain hose (3/4" ID, 1" OD) extends from the drain pan in the upper section of the unit and extends down to the unit base. An opening is supplied towards the back of the unit base for the drain hose to pass through, and the hose extends 1" to 2" below the unit base. Water removed from the indoor air (condensate) will be expelled from the unit in large amounts during cooling operation through the hose. Units running in cooling operation in cold outdoor below freezing conditions can cause the condensate to freeze after leaving the drain hose. In the event the drain hose is connected to a drain system of some type, it must be an open or vented type system to ensure proper drainage throughout seasonal use.

### Indoor Ducted and Non-Ducted Applications

Air distribution inside the structure being conditioned plays an important role in making sure the area is a consistent temperature. Improper air distribution can result in areas being cooler or warmer, electrical equipment not receiving sufficient airflow or occupancy discomfort felt inside an area. Thermostat or indoor temperature sensor placement inside the area being conditioned also plays an important role in indoor climate control.

### Indoor Supply Airflow

Indoor installation areas must provide a non-restrictive path for the conditioned supply air to leave supply grilles and registers. Inspect the area to ensure that all indoor portions of the room or rooms will have access to supply air. Ductwork may be used to ensure proper air circulation and all provided ductwork guidelines and clearances must be followed. Non-ducted applications must use a supply louver grille installed over the supply opening inside the room. Be sure to adjust supply deflectors to properly disperse the conditioned supply air to all parts of the room. Avoid closing sections of the supply grilles which would cause unneeded supply duct pressurization.

## Indoor Return Airflow

A non-restrictive path for room air returning to the center section of the unit must be provided inside the room. Avoid placing objects including furniture, electronics equipment, equipment racks and cabinets directly in front of the unit return grilles and registers. Bard recommends at least 2' between solid objects and return grilles or registers. Ductwork may be used to ensure proper air circulation and all provided ductwork guidelines and clearances must be followed. Non-ducted applications must use a return louver grille installed over the return opening inside the room.

## Ducted Applications

Field fabricated supply and return duct work may be installed inside the structure being conditioned. A short supply and/or return stub duct may be connected to the unit supply and return flanges before unit installation to help with duct connections inside the structure. Supply and return ducts must be properly sized for the design airflow requirement of the equipment. Air Conditioning Contractors of America (ACCA) is an excellent guide to proper sizing. All duct work or portions thereof not in the conditioned space should be properly insulated in order to conserve energy, reduce heat conductivity, and prevent condensation or moisture damage. Refer to Maximum External Static Pressure (ESP) of Operation Table 16 on page 48. Design the duct work according to methods given by the Air Conditioning Contractors of America (ACCA). When duct work is installed in unheated spaces, it should be insulated with a minimum of 1" of insulation. Use insulation with a vapor barrier on the outside of the insulation. Flexible joints should be used to connect the duct work to the equipment in order to keep the noise transmission to a minimum. Ducts through the walls must be insulated and all joints taped or sealed to prevent air or moisture from entering the wall cavity.

The unit itself is suitable for 0" clearance, but the supply air duct flange and the first 3' of supply air duct require a minimum of 1/4" clearance to combustible material for all models. However, it is generally recommended that a 1" clearance is used for ease of installation and maintaining the required clearance to combustible material. See Figure 3 on page 19 for details on opening sizes.

# WARNING

### **Fire hazard.**

**Maintain minimum 1/4" clearance between the supply air duct and combustible materials in the first 3' of ducting.**

**Failure to do so could result in fire causing damage, injury or death.**

## Free Blow Applications

Some installations may not require extensive supply duct work throughout the structure and are referred to as free blow applications. A short field-fabricated supply duct must be used in the wall cavity to transition between the supply collar on the unit and the supply louver grille in the room. The duct must be properly insulated in order to conserve energy, reduce heat conductivity and prevent condensation or moisture damage. All joints must be taped or sealed to prevent air or moisture entering the wall cavity. Follow all clearances including distances to combustible materials and all instructions provided in this manual. A non-restrictive metallic supply air grille with deflectors is required for free blow applications. Contact the local Bard distributor or visit [www.bardhvac.com](http://www.bardhvac.com) for ordering information.

A metallic return air grille is required for non-ducted applications. The spacing between louvers on the grille shall not be larger than 5/8". It is recommended that a Bard Return Air Grille Kit be installed that is designed specifically for the wall mount product. Contact the local Bard distributor or visit [www.bardhvac.com](http://www.bardhvac.com) for ordering information. A field-supplied return grille that meets the 5/8" louver criteria and does not cause the unit to exceed the maximum specified external static pressure (ESP) may be used. If using a return air filter grille, filters must be of sufficient size to allow a maximum velocity of 400 fpm. Filter return air grilles do not filter air being brought into the structure through ventilation options including fresh air dampers, ventilators, economizers and energy recovery ventilators. Be sure to install the return grille with the louvers pointed downward towards the floor. This will help ensure return air is drawn upward from the floor and improve air circulation in the room.

**NOTE:** *If no return air duct is used, applicable installation codes may limit this cabinet to installation only in a single story structure.*

## Thermostat or Indoor Temperature Sensor Placement

The location and installation of the thermostat or temperature sensor that monitors indoor temperature is very important regarding unit operation. Avoid placing the thermostat in an area exposed to direct sunlight or air from doorways leading outdoors. Use a piece of insulating material to close off conduit openings or holes in the wall surface for wire entry into the thermostat or temperature sensor. This will help avoid non-conditioned air from entering the thermostat and effecting temperature and/or humidity readings. As common practice, the thermostat or temperature sensor should measure the temperature of the air being returned to the unit, and not the conditioned air being supplied by the unit. Placing the thermostat or temperature sensor near a return air opening will normally result in optimal unit performance.

## Unit Installation

Make sure to have the proper tools at the work site that are needed for unit installation. The following steps are provided to ensure the unit is installed properly to the wall surface, and that the unit will provide years of service with minimal service requirements.

### Materials/Tools List

Additional hardware and miscellaneous supplies are needed for installation. These items are field supplied and must be sourced before installation. This list also includes tools needed for installation.

- Appropriate safety gear including gloves and safety glasses
- 5/16" hex bit with drill driver
- Phillips head screwdriver
- Small straight (thermostat) screwdriver
- Tape measure
- Leveling device
- Two (2) tubes of caulk and caulk gun
- Utility knife
- Tools for cutting holes in the wall surface (if needed)
- Electrical components and wiring along with electrical tools
- Multimeter
- Wall fasteners for side flanges, bottom mounting bracket and top rain flashing.
- Duct tape and/or other duct sealing materials.

### Wall Preparation

1. Two holes for the supply and return air openings must be cut through the wall as shown in Figure 3 on page 19. Be sure the openings are square and level. Follow all clearances including distances to combustible materials and all instructions provided in this manual.
2. Review all electrical requirements provided in this manual and plan out electrical entrances into the building. Also plan electrical conduit routing and thermostat placement, if necessary.
3. Install necessary duct work and prepare the openings for unit installation.
4. Clean the exterior wall where the unit is to be installed and make sure it is able to provide a smooth, level, debris-free surface. Remove all construction debris from the supply, return and electrical hole cutting process.

### Wall Mount Installation to Wall Surface

1. Remove packaging from unit and make sure unit is not damaged before installation. A top rain

flashing is supplied for field use and is mounted to the back of the unit for shipping. Remove rain flashing before locating the unit against wall. Top rain flashing is required to avoid water entering the area behind the unit that is against the wall. A bottom mounting bracket, attached to the skid for shipping, is provided for ease of installation but is not required. Review all requirements listed on unit labels and on serial plate located on the side of the unit.

2. Locate and mark bolt hole locations and bottom mounting bracket location. Install bottom mounting bracket with field-supplied fasteners to wall if it is to be used (optional). Bracket must be level and installed in the correct location to help support the unit during the installation process (see Figure 3).
3. Position the wall mount unit close to the wall surface where it will be installed. Install rain flashing at the top of the unit facing the wall by hooking the hem bend into the rear bend of the unit top (see Figure 3).
4. Apply a liberal amount of caulk on left and right cabinet side wall mount brackets and back of top rain flashing. Place unit back surface flush against wall. Unit must be level to ensure proper condensate drainage. Optional bottom bracket may be used to help support the unit.
5. Units are secured to the wall by using field-supplied fasteners along each side of the wall mount through the built-in wall mounting brackets. It is the responsibility of the installer to select the proper fastener to secure the unit to the wall based on wall construction and applicable building codes. Typical installations may include 5/16" fasteners with 7/8" diameter flat washers. Be sure unit is securely mounted and all weight-bearing fasteners are attached to the weight supporting structural members of the wall.
6. Apply a bead of caulk between the back of the unit top and the front surface of the top rain flashing (see Figure 3).
7. Connect unit duct work from the inside of the building following all clearances and instructions provided. For additional mounting rigidity, the return air and supply air frames or collars can be drilled and screwed or welded to the structural wall itself (depending upon wall construction). Be sure to use code approved duct tape or other sealing materials to seal the duct work to the unit.
8. On side-by-side installations, maintain a minimum of 20" clearance on right side to allow access to control panel and heat strips, and to allow proper airflow to the outdoor coil. Additional clearance may be required to meet local or national codes.

**TABLE 1**  
**Clearance Required for Service Access and**  
**Adequate Condenser Airflow**

Model	Left Side	Right Side
C24HF C30HF	15"	20"

**TABLE 2**  
**Minimum Clearances Required**  
**to Combustible Materials**

Model	Supply Air Duct (1st 3')	Cabinet
C24HF C30HF	1/4"	0"

1. Follow all national, state, and local codes and regulations regarding the installation of heating and cooling equipment regarding Single Packaged Vertical Units (SPVU) including electrical access clearances.
2. Field ventilation installation with the unit installed requires 40" on the left or right side of the unit.
3. Bard recommends a minimum of 10' between the unit front condenser air outlet and solid objects including fences, walls, bushes and other airflow obstructions.
4. Bard recommends a minimum of 15' between the condenser air outlets of two units that are facing each other.
5. Bard recommends a minimum clearance of 4" under the unit cabinet for condenser defrost drainage during heat pump operation.

**FIGURE 2**  
**Unit Dimensions**

	Width (W)	Depth (D)	Height (H)	Supply		Return		E	F	G	I	J	K	L	M	N	O	P	Q	R	S	T
				A	B	C	B															
C24HF C30HF	38.200	17.125	74.563	7.88	27.88	13.88	27.88	40.00	10.88	29.75	17.93	30.75	32.75	33.25	31.00	2.75	39.13	26.75	9.14	4.19	12.00	9.00

All dimensions are in inches. Dimensional drawings are not to scale.

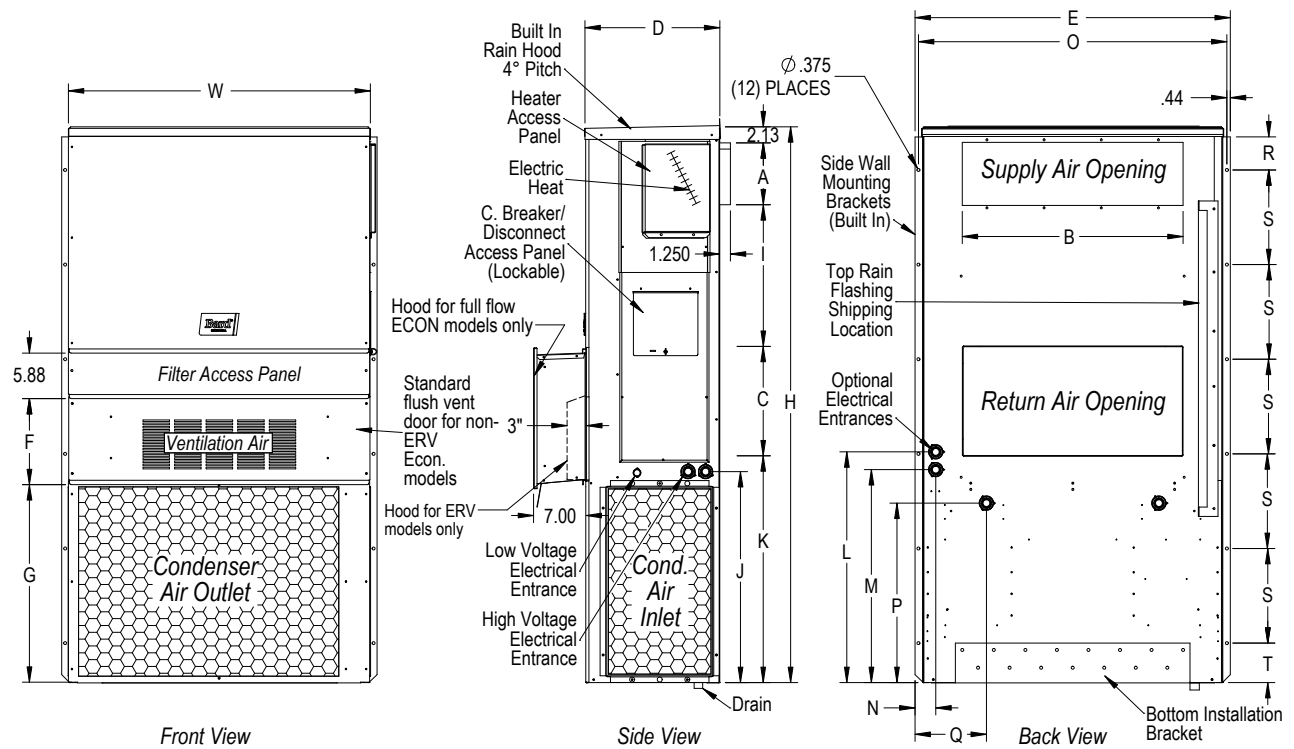

MIS-3976 B

**FIGURE 3**  
**C24HF, C30HF**  
**Mounting Instructions**

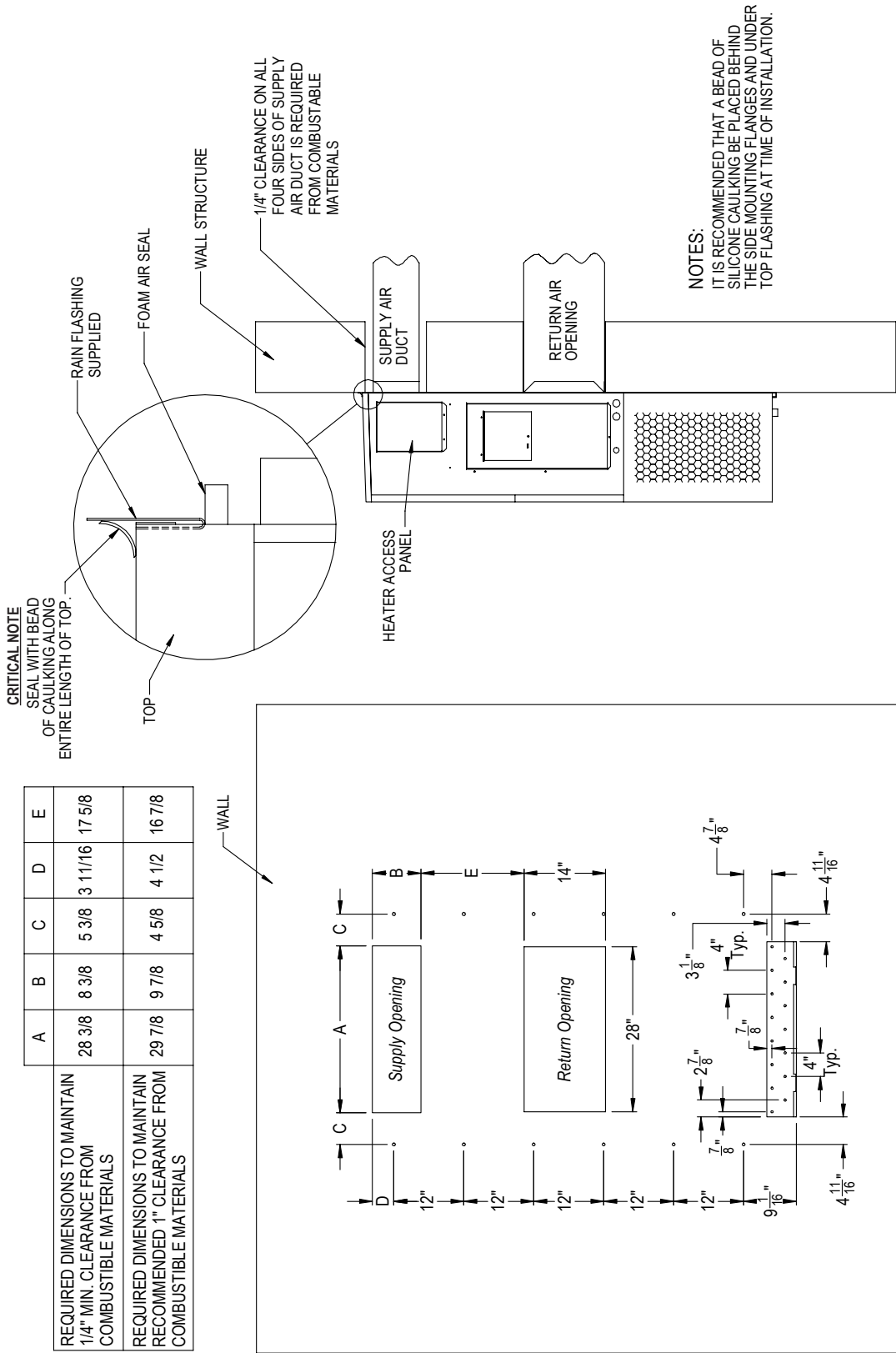

MIS-3158 A

Right Side View

Wall Opening and Hole Location View

**FIGURE 4**  
**Electric Heat Clearance – All Models**

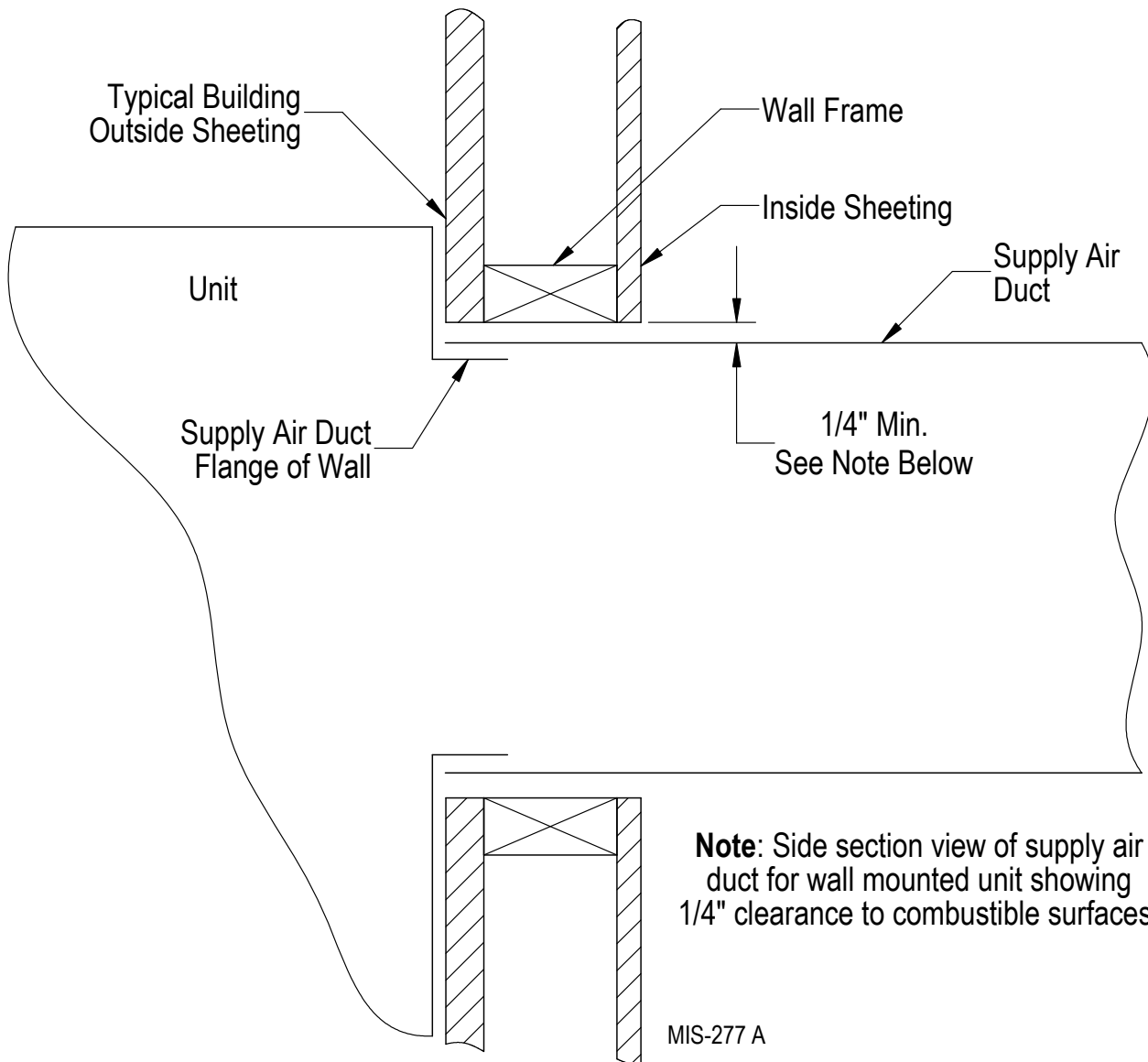

**⚠ WARNING**

**Fire hazard.**

**Maintain minimum 1/4" clearance between the supply air duct and combustible materials in the first 3' of ducting.**

**Failure to do so could result in fire causing damage, injury or death.**

**FIGURE 5**  
**Wall Mounting Instructions**

SEE FIGURE 3 – MOUNTING INSTRUCTIONS

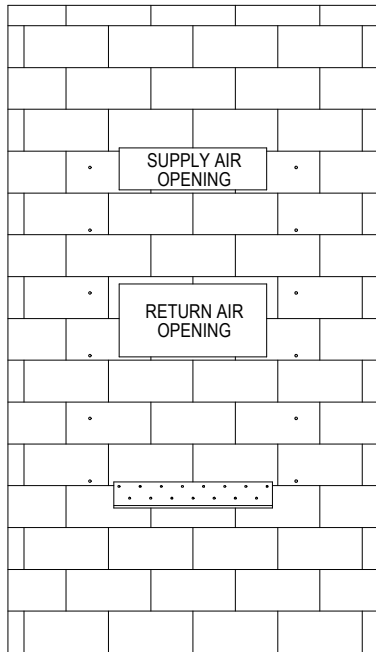

CONCRETE BLOCK WALL INSTALLATION

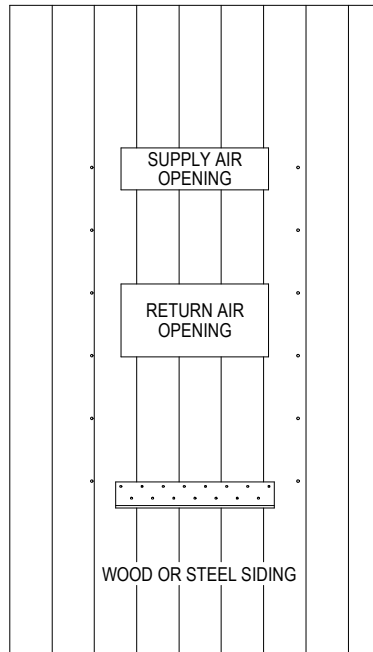

WOOD FRAME WALL INSTALLATION

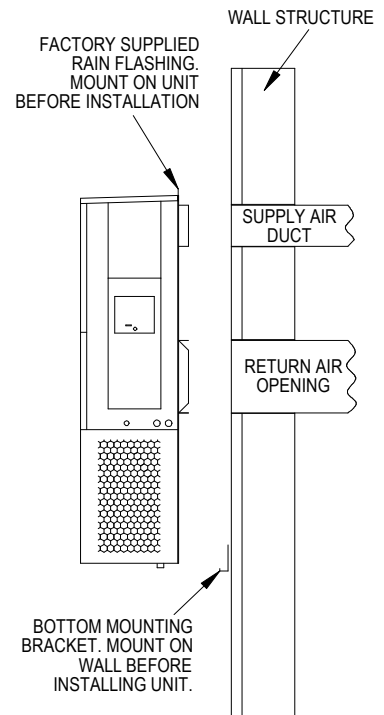

SIDE VIEW

MIS-548 A

**FIGURE 6**  
**Wall Mounting Instructions**

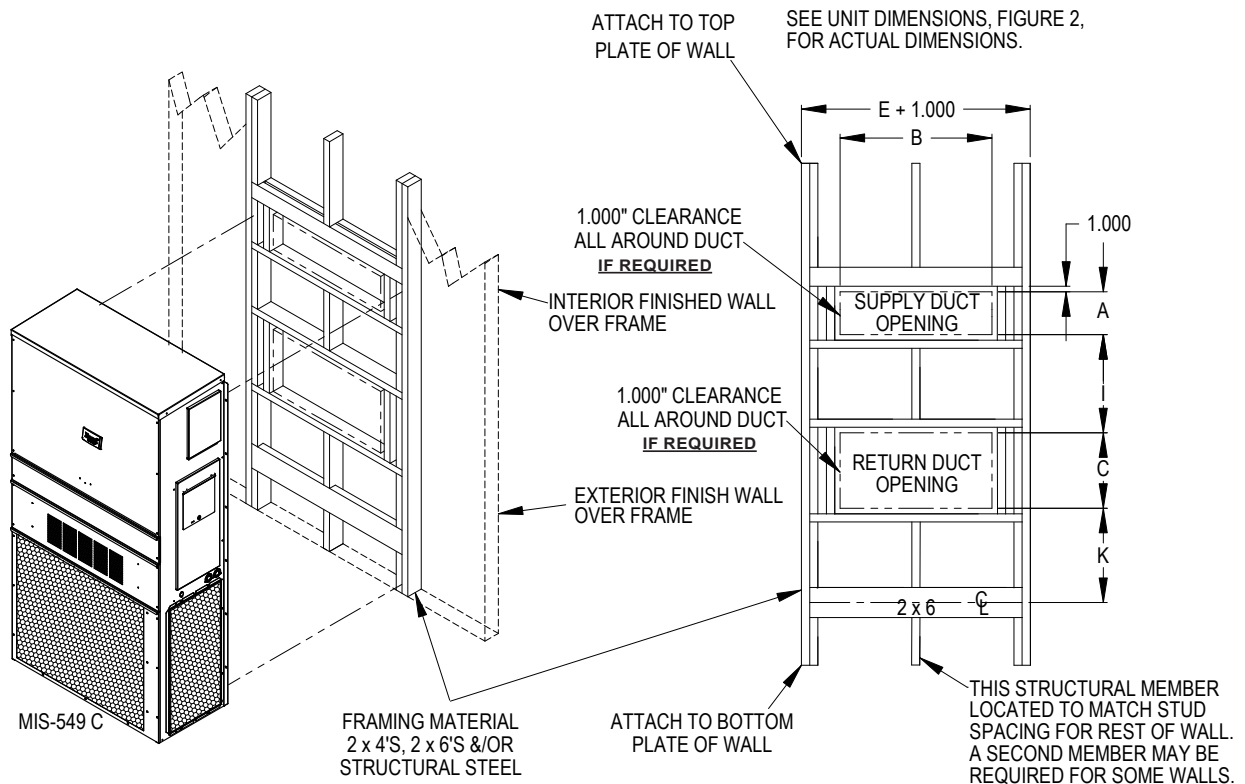

**FIGURE 7**  
**Common Wall Mounting Installations**

**Non-Ducted Installations**

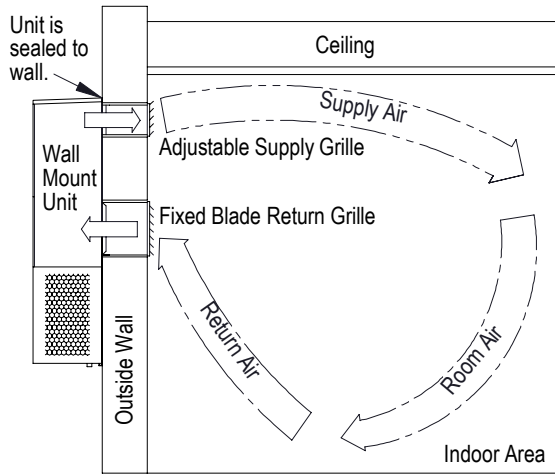

Non-ducted installations supply conditioned air into indoor room areas without extensive duct work. The supply airstream is directed by adjusting the 4-way supply grille to reach areas being conditioned. The supply air mixes with the room air and cools or heats occupants and/or equipment in the area. Unconditioned room air is returned to the unit through the return grille. Avoid supply air leaving supply grille and re-entering the unit return grille without mixing with room air.

**Ducted Installations**

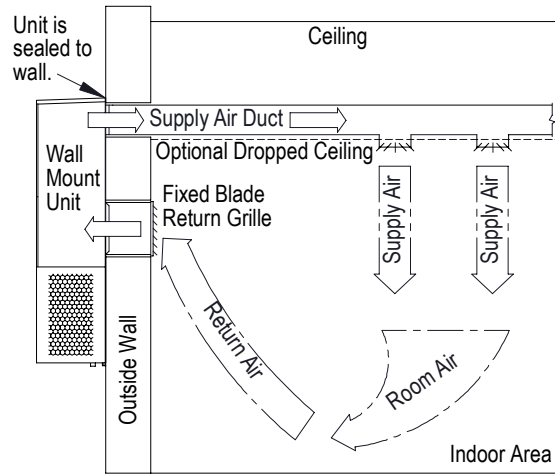

Ducted installations supply conditioned air into indoor room areas using solid or flexible ducts. The supply air is distributed throughout a single area or multiple areas. The supply air mixes with the room air and cools or heats occupants and/or equipment. Unconditioned room air is returned to the unit through a return grille or return duct work. Avoid using restrictive duct work to provide the best unit performance and efficiency. Review duct static pressure requirements provided in this manual.

**Outdoor Wall Curb Installations**

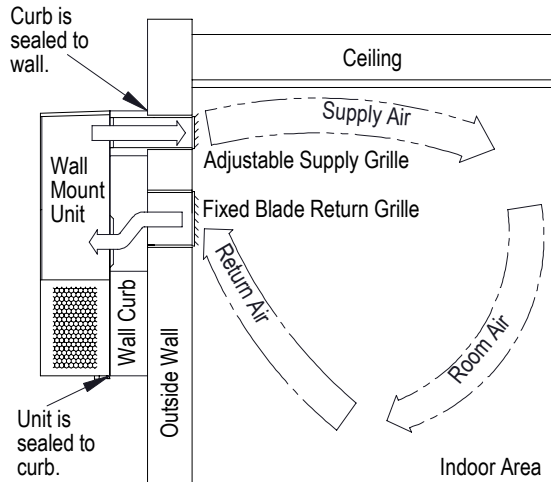

Outdoor Wall curbs are installed between the wall mount unit and the outer wall surface. Wall curb use may avoid resizing supply and return openings that are currently in an existing wall. Wall curbs may also provide sound isolation and indoor area sound reduction. Various curb options are available, and it is important to select a curb that will meet the application requirements and also be the correct size for the unit. Unit duct static requirements cannot be exceeded when using a wall curb. Follow all instructions provided with the wall curb when installing the product.

**WAPR11 Indoor Sound Plenum Installations**

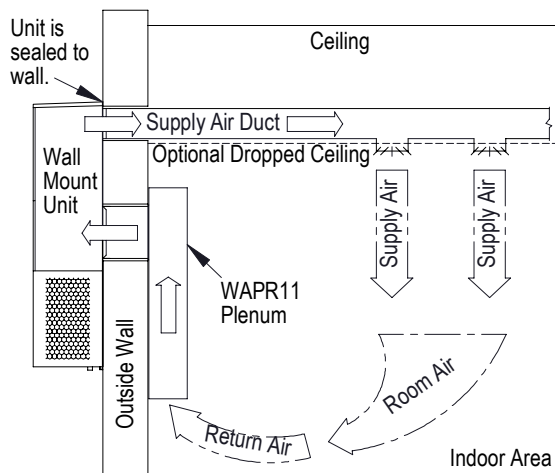

Indoor sound plenums are installed inside the room over the unit return air opening. Plenum use can provide sound isolation and indoor area sound reduction. The WAPR11 sound plenum provides a single solution for all unit tonnage sizes. The WAPR11 may be installed horizontally or vertically in the room. Unit duct static requirements cannot be exceeded when using a sound plenum. Follow all instructions provided with the sound plenum when installing the product.

MIS-550 D

## Wiring – Main Power

# WARNING

**Electrical shock hazard.**

**Do not operate this equipment without an earth ground attached and always disconnect the remote electric power supplies before servicing.**

**Electrical shock can result in serious injury or death.**

Refer to the unit rating plate for maximum fuse or circuit breaker size. Each outdoor unit is marked with a “Minimum Circuit Ampacity”. This means that the field wiring used must be sized to carry that amount of current. Depending on the installed kW of electric heat, there may be two field power circuits required. If this is the case, the unit serial plate will so indicate. All models are suitable only for connection with copper wire. Each unit and/or wiring diagram will be marked “Use Copper Conductors Only”. These instructions **must be** adhered to. Refer to the National Electrical Code (NEC) for complete current carrying capacity data on the various insulation grades of wiring material. All wiring must conform to NEC and all local codes.

The electrical data lists fuse sizes for all models including the most commonly used heater sizes. Also shown are the number of field power circuits required for the various models with heaters.

The unit rating plate lists a maximum fuse or circuit breaker that is to be used with the equipment. The correct size must be used for proper circuit protection and also to assure that there will be no nuisance tripping due to the momentary high starting current of the compressor motor.

The disconnect access door on this unit may be locked to prevent unauthorized access to the disconnect. To convert for the locking capability, bend the tab located in the bottom left-hand corner of the disconnect opening under the disconnect access panel straight out. This tab will now line up with the slot in the door. When shut, a padlock may be placed through the hole in the tab preventing entry.

See page 29 for important information on three phase scroll compressor start ups.

See Table 14 on page 44 for electrical specifications.

## Wiring – Low Voltage

All 230/208V 1 phase and 3 phase equipment have dual primary voltage transformers. All equipment leaves the factory wired on 240V tap. For 208V operation, reconnect from 240V to 208V tap. The acceptable operating voltage range for the 240 and 208V taps are:

TAP	RANGE
240	253 – 216
208	215 – 197

**NOTE:** The voltage should be measured at the field power connection point in the unit and while the unit is operating at full load (maximum amperage operating condition).

For low voltage wiring, an 18 gauge copper, color-coded cable is recommended. See Table 6 on page 25 for more information.

### Low Voltage Connections

These units use a 24-volt AC low voltage circuit.

**C** terminal is 24VAC common and is grounded.

**G** terminal is the indoor blower input.

**Y1** terminal is the compressor part load input.

**Y2** terminal is the compressor full load input.

**B/W1** terminal is the reversing valve input. The reversing valve must be energized for heating mode.

**W2** terminal is the 1st stage electric heat (if equipped). 1st stage electric heat can be operated simultaneously with the heat pump operating.

**W3** terminal is the 2nd stage of electric heat or emergency heat (if equipped). When W3 terminal is energized, it locks out compressor operation to limit discharge air temperature and required branch circuit ampacity.

**A** terminal is the ventilation input. This terminal energizes any factory-installed ventilation option and indoor blower.

**D** terminal is the dehumidification input. If installed, this terminal energizes any factory-installed dehumidification option.

**L** terminal is 24 volt alarm active output.

For units equipped with an alarm relay:

**1 terminal** is the normally closed contact on the relay.

**2 terminal** is the normally open contact on the relay.

**3 terminal** is the common contact on the relay.

### Unit Shutdown Feature (Standard on All Models)

The RT terminal is the 24VAC transformer output, and the R terminal is the 24VAC hot terminal for the operation of the equipment. RT and R are connected with a brass jumper bar which can be removed and RT and R connected to an external NC (normally closed) contact such as a fire/smoke detector that will cause shutdown of the equipment upon activation.

**TABLE 3**  
**Field Supplied Controls – Sequence of Operation**

Fan Only	Energize G
Cooling Mode 1st Stage	Energize G, Y1
Cooling Mode 2nd Stage	Energize G, Y1, Y2
Heat Pump Heating 1st Stage	Energize G, Y1, B/W1
Heat Pump Heating 2nd Stage	Energize G, Y1, Y2, B/W1
HP Heating FL + EH (Up to 10 kW)	Energize G, W2, Y1, Y2, B/W1
Heat Bank #1 (EH Only)	Energize G, W2
Emergency Heat (HP operation is negated for this condition)	Energize, G, W2, W3
Dehumidification (if employed)	Energize D
Ventilation	Energize A

**Dehumidification Feature (Optional)**

The D terminal is the 24VAC input for dehumidification operation on dehumidification hot gas reheat equipped units. When 24VAC is applied to the D terminal, a 3-way valve solenoid is energized. The reheat coil located behind the evaporator coil is then active to reheat the supply air during cooling mode. This allows humidity to be removed from the air entering the unit without a large amount of sensible cooling capacity. During dehumidification, the indoor blower speed is reduced to help with the humidity removal. A humidity sensing thermostat or humidistat is required to control dehumidification operation.

**Ventilation Features (Optional)**

See ventilation instructions provided with unit for low voltage wiring.

**Low Ambient Control (LAC)**

The low ambient control is a pressure switch that is attached to the liquid line of the system and monitors high side pressure. Operation of the LAC occurs as outdoor temperatures drop below 60°F. On/Off and modulating controls are used which operate based on pressure changes caused by outdoor temperature changes. On/Off LAC operation cycles the condenser fan on/off to maintain desired liquid pressure while modulating LAC operation is factory adjusted and slows the condenser fan speed (rpm).

**Freeze Protection Thermostat**

An evaporator freeze protection thermostat is supplied with all units that have a low ambient control. The freeze thermostat cuts out compressor operation if the evaporator begins to freeze up.

**Alarm Relay Feature (Controls Option)**

The alarm relay provides a set of NO (normally open) and NC (normally closed) pilot duty contacts that operate when the compressor control module locks out compressor operation because of a high or low system refrigerant pressure event.

**Dirty Filter Switch Indicator (DFS)**

The switch is adjustable and measures pressure drop across the unit filter surface. When pressure drop is higher than the switch setting, NO contacts are provided to indicate the filter needs to be serviced. Refer to page 47 for instructions on making switch adjustments.

**Refrigerant Leak Detection System (RDS)**

The RDS continuously monitors air in the indoor section of the unit for leaked refrigerant. In the event of a refrigerant leak, the RDS will initiate mitigation actions to disperse the refrigerant and prevent potentially dangerous refrigerant concentration levels. The RDS will also provide a 24VAC alarm output signal on the "L" terminal of the unit low-voltage terminal strip.

Refer to page 37 for more information.

**TABLE 4**  
**Wall Thermostats**

Thermostat	Predominant Features
8403-060 (1120-445)	3 Stage Cool, 3 Stage Heat Programmable/Non-Programmable Electronic HP or Conventional Auto or Manual Changeover Dehumidification Output
8403-081 (BrightStat)	2 Stage Cool, 2 Stage Heat Programmable/Non-Programmable Electronic HP or Conventional Auto or Manual Changeover with Humidity and Occupancy Sensor BACnet (Thermostat option only permissible for units up to 12 kW electric heat)
8403-083 (BrightStat)	2 Stage Cool, 2 Stage Heat Programmable/Non-Programmable Electronic HP or Conventional Auto or Manual Changeover with Humidity (only) BACnet (Thermostat option only permissible for units up to 12 kW electric heat)
8403-090 (T6 Pro)	2 Stage Cool, 3 Stage Heat – Heat Pump 2 Stage Cool, 2 Stage Heat – Conventional Programmable/Non-Programmable Electronic Auto or Manual Changeover
8403-092 (T6 Pro Wi-Fi)	2 Stage Cool, 3 Stage Heat – Heat Pump 2 Stage Cool, 2 Stage Heat – Conventional Programmable/Non-Programmable Electronic Auto or Manual Changeover Wi-Fi

**TABLE 5**  
**Humidity Controls**

Part Number	Predominate Features
8403-100* (H6062A1000)	Electronic humidistat DPST Humidity range 10-90% with adjustable stops
8403-047 (H200-10-21-10)	Electronic dehumidistat SPST, closes-on-rise Humidity range 10-90% with adjustable stops

\* If using 8403-100 humidistat, it must be configured for dehumidification in the Setup menu.

**TABLE 6**  
**Thermostat Wire Size**

Transformer VA	FLA	Wire Gauge	Maximum Distance In Feet
55	2.3	18 gauge	60
		16 gauge	100
		14 gauge	160
		12 gauge	250

**TABLE 7**  
**CO<sub>2</sub> Controllers**

Part Number	Predominate Features
8403-096	Normally Open SPST relay closes-on-rise 24V dual wave length sensor. Default setting 950ppm, adjustable to 0-2000ppm Default off setting 1000ppm, adjustable to 0-200 ppm can be calibrated

**FIGURE 8**  
**Programmable Thermostat Connections**

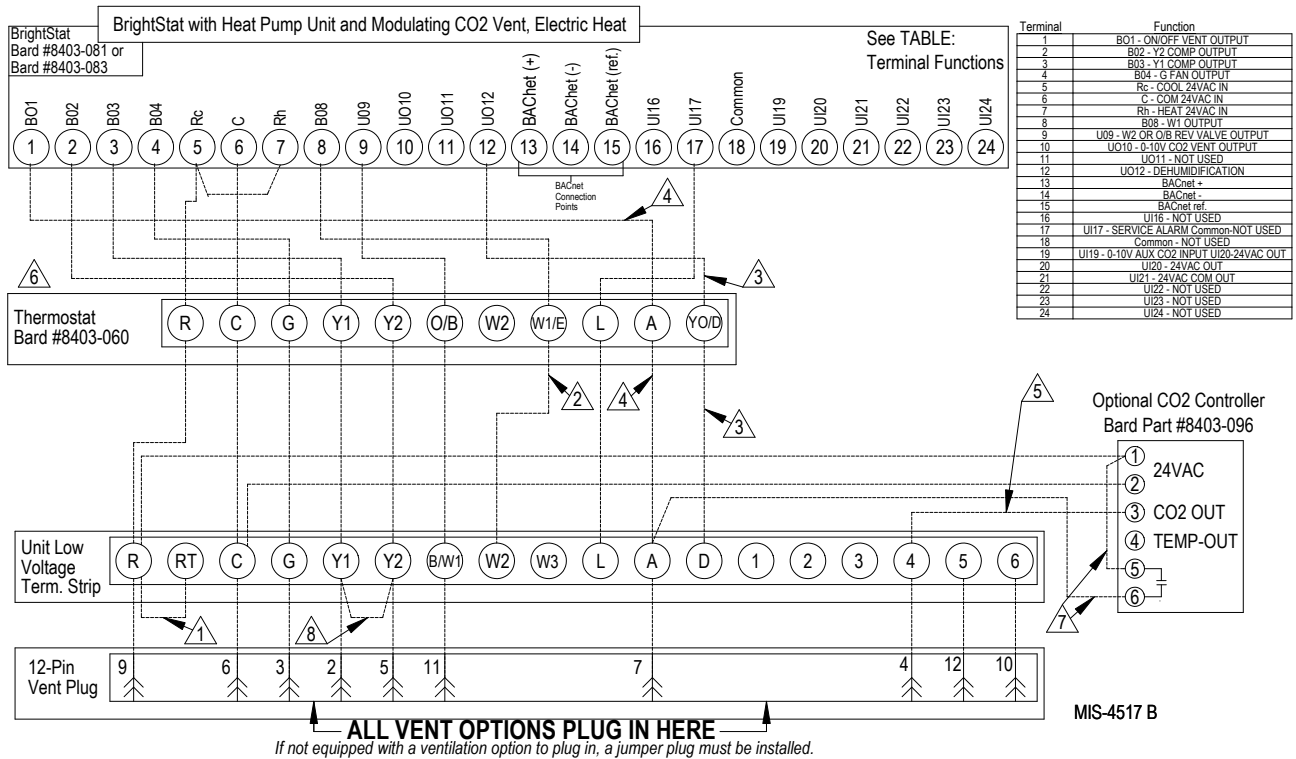

- ① Factory installed jumper. Remove jumper and connect to N.C fire alarm circuit if emergency shutdown required.
- ② Outdoor thermostat controls option required for 12kW to 15kW electric heat and use of Brightstat.
- ③ Wire required for dehumidification models only.
- ④ Do not connect "A" from thermostat if optional CO2 controller is used
- ⑤ 0-10 VDC modulating CO2 control signal for modulating ventilation control (optional for ECON only - see vent instruction manuals)
- ⑥ Ensure model configuration is heat pump and not heat/cool. Must be configured to programmable and fan set to be programmed fan for the "A" output to function during scheduled occupied periods. Must be configured for multi-stage for Y1 output to be active 1st stage cooling. For dehumidification, must be configured for "No Economizer" for YO/D to be active for humidity control.
- ⑦ Do not add these wires if setting up for modulating control.
- ⑧ Factory installed jumper. Remove jumper to activate Balanced Climate TM Mode. A 2-stage thermostat is recommended for balanced climate mode. Y1 Y2 jumper not present if economizer is factory installed. Units with economizers have balanced climate jumper in economizer, refer to economizer manual. The jumper is factory removed in the unit and on jade for C\*\*H models.

**FIGURE 9**  
**Non-Programmable Thermostat Connections**

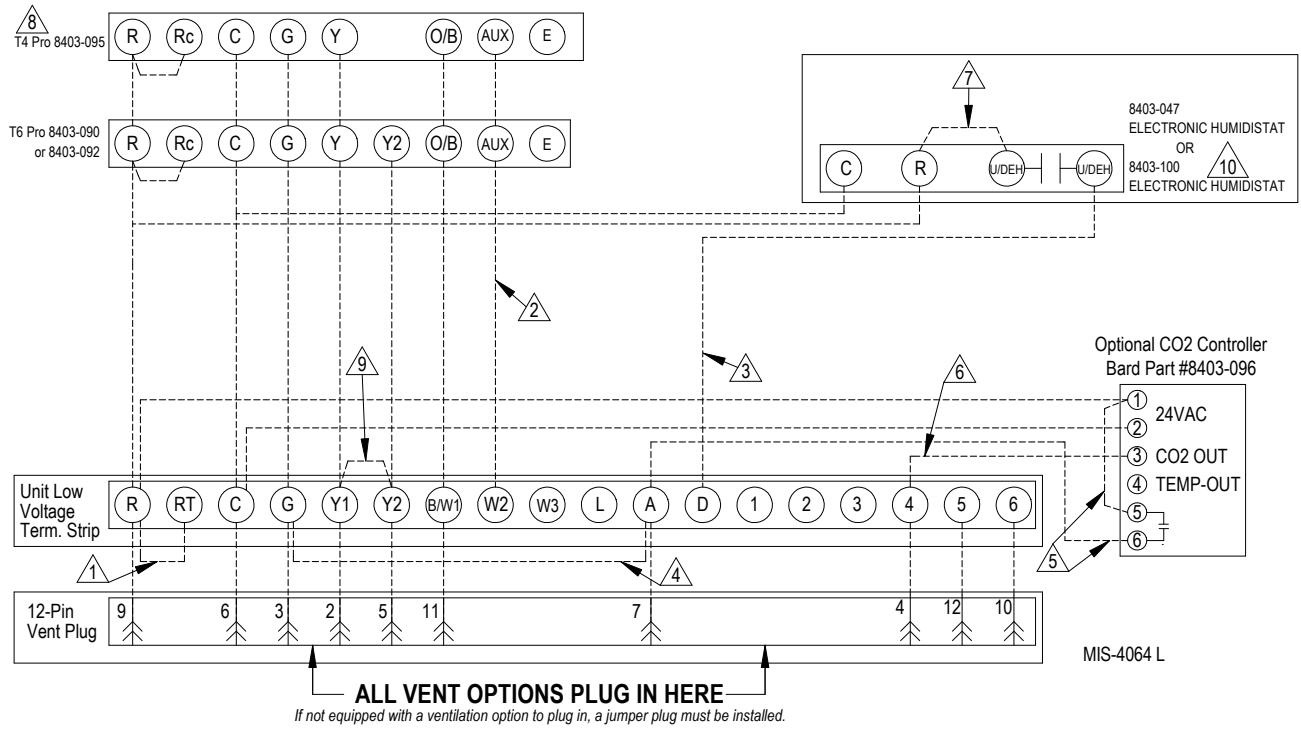

- ⚠️ FACTORY INSTALLED JUMPER. REMOVE JUMPER AND CONNECT TO N.C FIRE ALARM CIRCUIT IF EMERGENCY SHUTDOWN REQUIRED.
- ⚠️ AUX WILL ENERGIZE SECOND HEAT CONTACTOR IF COMPRESSOR IS NOT ACTIVE. THERMOSTAT SELECTED SHALL NOT ALLOW SIMULTANEOUS OUTPUT ON "Y" WHEN "W2" IS ENERGIZED.
- ⚠️ WIRE REQUIRED FOR DEHUMIDIFICATION MODELS ONLY.
- ⚠️ FOR VENT OPERATION. ADD JUMPER IF OPTIONAL CO2 CONTROLLER IS NOT USED. VENT WILL RUN WHILE BLOWER IS ENERGIZED. FOR ECON & CRV-V, AN ADDITIONAL WIRE CHANGE IS REQUIRED. SEE INSTALL MANUAL.
- ⚠️ DO NOT ADD THESE WIRES IF SETTING UP FOR MODULATING CONTROL. SEE NOTE 6.
- ⚠️ 0-10 VDC MODULATING CO2 CONTROL SIGNAL FOR MODULATING VENTILATION CONTROL (OPTIONAL FOR ECON ONLY) - SEE VENT INSTALLATION MANUAL.
- ⚠️ JUMPER NEEDS ADDED.
- ⚠️ THERMOSTAT IS INCOMPATIBLE WITH SYSTEMS THAT ARE EQUIPPED WITH ECONOMIZERS. MEANING IF THE UNIT HAS AN ECONOMIZER, THE THERMOSTAT WILL NOT FUNCTION PROPERLY WITH AN ECONOMIZER.
- ⚠️ FACTORY INSTALLED JUMPER. REMOVE JUMPER TO ACTIVATE BALANCED CLIMATE™ MODE. A 2-STAGE THERMOSTAT IS RECOMMENDED FOR BALANCED CLIMATE MODE. Y1 Y2 JUMPER NOT PRESENT IF ECONOMIZER IS FACTORY INSTALLED. UNITS WITH ECONOMIZERS HAVE BALANCED CLIMATE JUMPER IN ECONOMIZER. REFER TO ECONOMIZER MANUAL. THE JUMPER IS FACTORY REMOVED IN THE UNIT AND ON JADE FOR C-HY MODELS.
- ⚠️ HUMIDISTAT 8403-100 WILL NEED TO BE CONFIGURED FOR DEHUMIDIFICATION IN THE MENU. SEE USER'S MANUAL.

## START UP

### NOTICE

These units require R-454B refrigerant and polyol ester oil.

#### General

1. R-454B refrigerant is classified as an A2L, or mildly flammable refrigerant. Refer to A2L Refrigerant Safety Manual 2100-810 for information regarding safe practices for charging, recovering, decommissioning and general handling of A2L refrigerants.
2. Use separate service equipment to avoid cross contamination of oil and refrigerants.
3. Use recovery equipment rated for R-454B refrigerant.
4. Use manifold gauges rated for R-454B (800 psi/250 psi low).
5. R-454B is a zeotropic blend of HFC-32 and HFO-1234yf. Charge with liquid refrigerant.
6. R-454B has an ozone depletion potential of zero, but must be recovered due to its global warming potential.
7. R-454B compressors use polyol ester oil.
8. Polyol ester oil is hygroscopic; it will rapidly absorb moisture and strongly hold this moisture in the oil.
9. A liquid line dryer must be used—even a deep vacuum will not separate moisture from the oil.
10. Limit atmospheric exposure to 15 minutes.
11. If compressor removal is necessary, always plug compressor immediately after removal. Purge with small amount of nitrogen when inserting plugs.

#### Topping Off System Charge

If a leak has occurred in the system, Bard Manufacturing recommends recovering, evacuating (see manual 2100-810) and charging to the nameplate charge.

Since R-454B is a zeotropic blend, one component may leak off before another component in the event of a leak. This can cause significant changes to the concentration of each component in the system. For this reason, Bard Manufacturing does not recommend topping off the system charge.

**REMEMBER:** When adding R-454B refrigerant, it must come out of the charging cylinder/tank as a liquid to avoid any fractionation, and to ensure optimal system performance. Refer to instructions for the cylinder that is being utilized for proper method of liquid extraction.

### WARNING

**Failure to conform to these practices could lead to damage, injury or death.**

#### Safety Practices

1. Never mix R-454B with other refrigerants.
2. Use gloves and safety glasses. Polyol ester oils can be irritating to the skin, and liquid refrigerant will freeze the skin.
3. Never use air and R-454B to leak check; the mixture is flammable.
4. Do not inhale R-454B—the vapor attacks the nervous system, creating dizziness, loss of coordination and slurred speech. Cardiac irregularities, unconsciousness and ultimate death can result from breathing this concentration.
5. Do not burn R-454B. This decomposition produces hazardous vapors. Evacuate the area if exposed.
6. Use only cylinders rated DOT4BA/4BW 400.
7. Never fill cylinders over 80% of total capacity.
8. Store cylinders in a cool area, out of direct sunlight.
9. Never heat cylinders above 125°F.
10. Never trap liquid R-454B in manifold sets, gauge lines or cylinders. R-454B expands significantly at warmer temperatures. Once a cylinder or line is full of liquid, any further rise in temperature will cause it to burst.

#### Important Installer Note

For improved start-up performance, wash the indoor coil with dishwashing detergent.

#### High Pressure Switch

All W\*\*H Series wall-mounted heat pump models are supplied with a remote reset for the high and low pressure switch. If tripped, this pressure switch may be reset by turning the thermostat off then back on again. High pressure switch settings: Opens 615 +/- 15 PSI, Closes 490 +/- 15 PSI.

## Three Phase Scroll Compressor Start Up Information

Scroll compressors, like several other types of compressors, will only compress in one rotational direction. Upon start up, direction of rotation is not an issue with single phase compressors since they will always start and run in the proper direction.

However, three phase compressors will rotate in either direction depending upon phasing of the power. Since there is a 50-50 chance of connecting power in such a way as to cause rotation in the reverse direction, verification of proper rotation must be made. Verification of proper rotation direction is made by observing that suction pressure drops and discharge pressure rises when the compressor is energized. Reverse rotation also results in an elevated sound level over that with correct rotation, as well as substantially reduced current draw compared to tabulated values.

Verification of **proper rotation** must be made at the time the equipment is put into service. If improper rotation is corrected at this time, there will be no negative impact on the durability of the compressor. However, reverse operation for over 1 hour may have a negative impact on the bearing due to oil pump out.

**NOTE:** *If compressor is allowed to run in reverse rotation for several minutes, the compressor's internal protector will trip.*

All three phase ZP compressors are wired identically internally. As a result, once the correct phasing is determined for a specific system or installation, connecting properly phased power leads to the same Fusite terminal should maintain proper rotation direction.

The direction of rotation of the compressor may be changed by reversing any two line connections to the unit.

## Phase Monitor

All units with three phase scroll compressors are equipped with a three phase line monitor to prevent compressor damage due to phase reversal.

The phase monitor in this unit is equipped with two LEDs. If the Y signal is present at the phase monitor and phases are correct, the green LED will light.

If phases are reversed, the red fault LED will be lit and compressor operation is inhibited.

If a fault condition occurs, reverse two of the supply leads to the unit. **Do not reverse any of the unit factory wires as damage may occur.**

## Condenser Fan Operation

**NOTE:** *Certain models may be equipped with a low ambient control (LAC), and if so, the condenser fan motor will have a delayed start until system refrigerant operating pressure builds up. After starting, the fan*

*motor may or may not cycle depending upon ambient conditions. This is normal operation.*

## Sequence of Operation

### Cooling Stage 1

Circuit R-Y1 makes at thermostat pulling in compressor contactor, starting the compressor and outdoor motor. (See **NOTE** under **Condenser Fan Operation** concerning models equipped with low ambient control.) The G (indoor motor) circuit is automatically completed by the thermostat on any call for cooling operation or can be energized by manual fan switch on subbase for constant air circulation.

### Cooling Stage 2

Circuit R-Y1 & Y2 makes at the thermostat energizing the 2nd stage solenoid in the compressor. The default position of the compressor staging solenoid is non-energized. The compressor will run at low capacity until this solenoid is energized.

### Heating Stage 1

A 24V solenoid coil on reversing valve controls heating cycle operation. Two thermostat options, one allowing "Auto" changeover from cycle to cycle and the other constantly energizing solenoid coil during heating season and thus eliminating pressure equalization noise except during defrost, are to be used. On "Auto" option, a circuit is completed from R-B and R-Y1 on each heating "on" cycle, energizing reversing valve solenoid and pulling in compressor contactor starting compressor and outdoor motor. R-G also make starting indoor blower motor. Heat pump heating cycle now in operation. The second option has no "Auto" changeover position, but instead energizes the reversing valve solenoid constantly whenever the system switch on thermostat is placed in "Heat" position, the "B" terminal being constantly energized from R. A thermostat demand for Stage 1 heat completes R-Y1 circuit, pulling in compressor contactor starting compressor and outdoor motor. R-G also make starting indoor blower motor.

### Heating Stage 2

Circuit R-Y1 & B continue to be energized. Circuit R-Y2 makes at the thermostat energizing the 2nd stage solenoid in the compressor.

### Heating Stage 2 and Electric Heat (Up to 10 kW)

Circuit R-Y1, Y2 & B continue to be energized for heating stage 2. On the a call for electric heat, circuit R-W2 makes at the thermostat, pulling in the heat contactor for the strip heat.

### Emergency Heat

The thermostat, or outdoor thermostat option, drops out the heat pump call. Circuit R-W2 continues to be energized. Upon the dropping out of the compressor

signal, the emergency heat relay pulls in the second heat contactor, if equipped.

### Low Ambient Conditions

If the application is likely to require air conditioning operation below 60°F outdoor conditions, a low ambient control (LAC) kit must be installed. The LAC kit also comes with an evaporator freeze protection thermostat that cuts out the compressor if the evaporator begins to freeze up.

**If the unit is being installed with any ventilation package, a Bard LAC kit must be installed.** Failure to utilize an LAC with any heat pump can cause coil freeze up.

### Defrost Cycle

The defrost cycle is controlled by temperature and time on the solid state heat pump control.

When the outdoor temperature is in the lower 40°F temperature range or colder, the outdoor coil temperature is 32°F or below. This coil temperature is sensed by the coil temperature sensor mounted near the bottom of the outdoor coil. Once coil temperature reaches 30°F or below, the coil temperature sensor sends a signal to the control logic of the heat pump control and the defrost timer will start accumulating run time.

After 30, 60 or 90 minutes of heat pump operation at 30°F or below, the heat pump control will place the system in the defrost mode.

During the defrost mode, the refrigerant cycle switches back to the cooling cycle, the outdoor motor stops, electric heaters are energized and hot gas passing through the outdoor coil melts any accumulated frost. When the temperature rises to approximately 57°F, the coil temperature sensor will send a signal to the heat pump control which will return the system to heating operations automatically.

If some abnormal or temporary condition such as a high wind causes the heat pump to have a prolonged defrost cycle, the heat pump control will restore the system to heating operation automatically after 8 minutes.

The heat pump defrost control board has an option of 30-, 60- or 90-minute setting. By default, this unit is shipped from the factory with the defrost time on the 60-minute pin. If circumstances require a change to another time, remove the wire from the 60-minute terminal and reconnect to the desired terminal. Refer to Figure 10 on page 32.

There is a cycle speed up jumper on the control. This can be used for testing purposes to reduce the time between defrost cycle operation without waiting for time to elapse.

Use a small screwdriver or other metallic object, or another 1/4" QC, to short between the *SPEEDUP*

terminals to accelerate the HPC timer and initiate defrost.

Be careful not to touch any other terminals with the instrument used to short the *SPEEDUP* terminals. It may take up to 10 seconds with the *SPEEDUP* terminals shorted for the speedup to be completed and the defrost cycle to start.

### As soon as the defrost cycle kicks in, remove the shorting instrument from the *SPEEDUP* terminals.

Otherwise the timing will remain accelerated and run through the 1-minute minimum defrost length sequence in a matter of seconds and will automatically terminate the defrost sequence.

There is an initiate defrost jumper (sen jump) on the control that can be used at any outdoor ambient during the heating cycle to simulate a 0°F coil temperature.

This can be used to check defrost operation of the unit without waiting for the outdoor ambient to fall into the defrost region.

By placing a jumper across the *SEN JMP* terminals (a 1/4" QC terminal works best) the defrost sensor mounted on the outdoor coil is shunted out and will activate the timing circuit. This permits the defrost cycle to be checked out in warmer weather conditions without the outdoor temperature having to fall into the defrost region.

In order to terminate the defrost test, the *SEN JMP* jumper must be removed. If left in place too long, the compressor could stop due to the high pressure control opening because of high pressure condition created by operating in the cooling mode with outdoor fan off. Pressure will rise fairly fast as there is likely no actual frost on the outdoor coil in this artificial test condition.

There is also a 5-minute compressor time delay function built into the HPC. This is to protect the compressor from short cycling conditions. The board's LED will have a fast blink rate when in the compressor time delay. In some instances, it is helpful to the service technician to override or speed up this timing period and shorting out the *SPEEDUP* terminals for a few seconds can do this.

### Low Pressure Switch Bypass Operation

The control has a selectable (SW1) low pressure switch bypass set up to ignore the low pressure switch input during the first (30, 60, 120 or 180 seconds) of "Y" operation.

After this period expires, the control will then monitor the low pressure switch input normally to make sure that the switch is closed during "Y" operation.

### High Pressure Switch Operation

The control has a built-in lockout system that allows the unit to have the high pressure switch trip up to two times in 1 hour and only encounter a "soft" lockout. A "soft" lockout shuts the compressor off and waits for the pressure switch to reset, which at that point

then allows the compressor to be restarted as long as the 5-minute short cycle timer has run out. If the high pressure switch trips a third time within 1 hour, the unit is in "hard" lockout indicating something is certainly wrong and it will not restart itself.

## Vent Connection Plug

All units are equipped with a vent connection plug in the side of the control panel for the different ventilation packages to plug in to. If the compressor will not start and there is no "Y1" at the defrost board, first check to make sure that either the optional vent is plugged into the vent connection plug or the supplied jumper plug is in place. **The unit will not operate without anything plugged in.** This plug is located on the side of the control panel behind the front vent door (behind the filter access door). If the unit is supplied with a factory-installed vent package, it will be plugged in but the jumper plug will also be tethered next to the connection for troubleshooting purposes, if necessary.

## Pressure Service Ports

High and low pressure service ports are installed on all units so that the system operating pressures can be observed. Pressure tables covering all models can be found on pages 42 and 43. It is imperative to match the correct pressure table to the unit by model number.

This unit employs high-flow Coremax valves instead of the typical Schrader-type valves.

***WARNING! Do NOT use a Schrader valve core removal tool with these valves. Use of such a tool could result in eye injuries or refrigerant burns!***

To change a CoreMax valve without first removing the refrigerant, a special tool is required. This specialty tool, CoreMax Valve Removal/Replace Tool SCRT20A, can be obtained at [www.fastestinc.com](http://www.fastestinc.com). See the replacement parts manual for replacement core part numbers.

## Service Hints

1. Caution owner/operator to maintain clean air filters at all times and to not needlessly close off supply and return air registers. This reduces airflow through the system, which shortens equipment service life as well as increasing operating costs.
2. Check all power fuses or circuit breakers to be sure they are the correct rating.
3. Periodic cleaning of the outdoor coil to permit full and unrestricted airflow circulation is essential.

**FIGURE 10**  
**Defrost Control Board**

SW 1	SW 2	TIME (SEC)
OFF	OFF	30
ON	OFF	60
OFF	ON	120*
ON	ON	180

LOW PRESSURE BYPASS TIMER SWITCH  
\*(FACTORY SETTING 120 SECONDS)

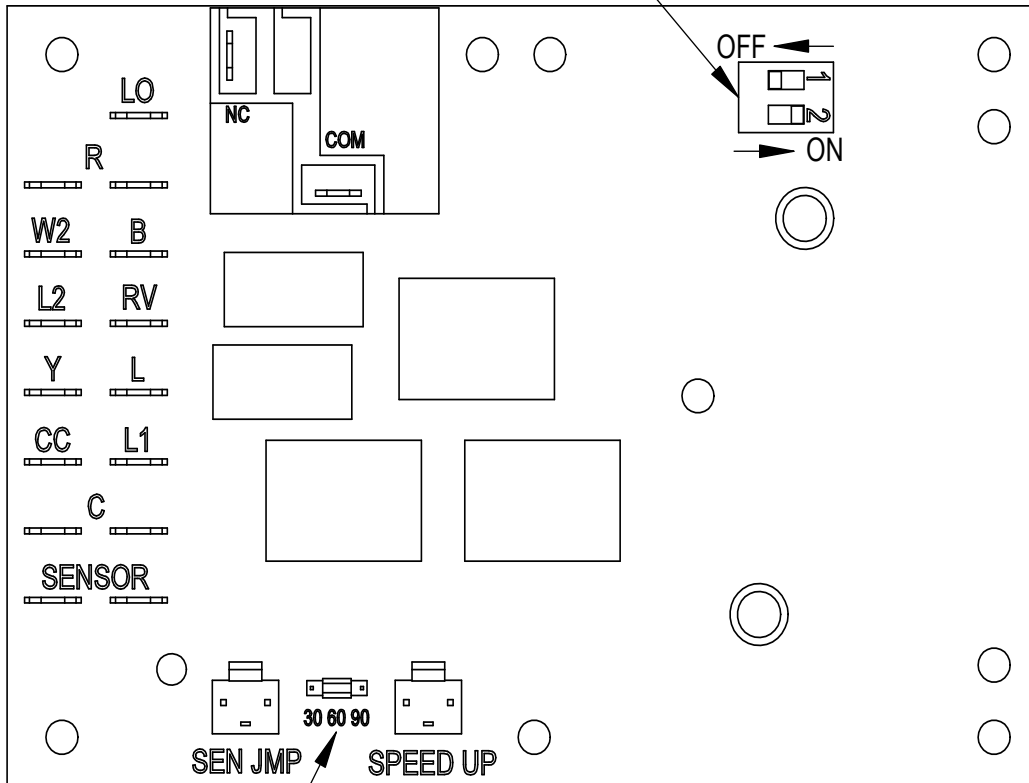

ACCUMULATED DEFROST TIME TIMER  
(FACTORY SETTING 60 MIN.)

MIS-2668 A

Model	Setting
C24HF	60
C30HF	60

## Solid State Heat Pump Control Troubleshooting Procedure

1. **NOTE:** A thorough understanding of the defrost cycle sequence is essential. Review that section (page 31) prior to troubleshooting the control. Turn on AC power supply to unit.
2. Turn thermostat blower switch to “fan on”—the indoor blower should start. (If it doesn’t, troubleshoot indoor unit and correct problem.)
3. Turn thermostat blower to “auto” position. Indoor blower should stop. **NOTE:** Many models have a 1-minute blower time delay on “off” command; wait for this to time out.
4. Set system switch to “heat” or “cool”. Adjust thermostat to call for heat or cool. The indoor blower, compressor and outdoor fan should start.

**NOTE:** If there was no power to 24 volt transformer, the compressor and outdoor fan motor will not start for 5 minutes. This is because of the compressor short cycle protection.

LED Blink Codes	
Blink	Function
Slow	Normal function (1.0 sec on/1.0 sec off)
Fast	Compressor Delay timer active (0.1 sec on/0.1 sec off)
1	Low pressure switch failure
2	High pressure switch failure/“Soft” Lockout
3	Defrost mode active
4	High pressure switch failure/“Hard” Lockout

**TABLE 8 – Troubleshooting**

Symptom	Description, Check and Possible Causes	What & How to Check / Repair
Compressor will not start (heating or cooling)	<b>1. Check for LED illumination.</b> Is there an LED illuminated on the board (flashing)?	Yes = go to Step #2; No = go to Step #3
	<b>2. Check for error codes.</b> Is the LED flashing a Code?	Yes = go to Step #4; No = go to Step #8
	<b>3. Check for power at board.</b> Is there 24 volts AC between R and C?	Yes = go to Step #13; No = go to Step #9
	<b>4. Check codes.</b> What code is blinking?	Code "1", go to Step #6; Code "2", go to Step#7; Fast Blink, go to Step #5
	<b>5. Compressor delay active.</b> Wait for 5 minute delay or jump board's "speed up pins".	Check for proper operation; if still needed, go back to Step #1.
	<b>6. Low pressure fault.</b>	Check wiring circuit and unit pressures.
	<b>7. High pressure fault.</b>	Check wiring circuit and unit pressures.
	<b>8. Check for Compressor input signal.</b> Is there 24 volts AC between Y and C?	Yes = go to Step #10; No = go to Step #11
	<b>9. No power to board.</b>	The unit either does not have unit voltage, the transformer is bad or the unit wiring is incorrect.
	<b>10. Check for Compressor output signal.</b> Is there 24 volts AC between CC & C?	Yes = go to Step #12; No = go to Step #13
	<b>11. No "Y" compressor input signal.</b>	Check thermostat wiring, incorrect phase of unit (see section on Phase Monitor), and finally unit wiring.
	<b>12. No "CC" compressor output signal.</b>	Check compressor contactor for proper operation and finally check compressor.
	<b>13. Faulty board.</b>	Replace defrost board.
Fan outdoor motor does not run (cooling or heating except during defrost)	Heat pump control defective	Check across fan relay on heat pump control. (Com-NC) Replace heat pump control.
	Motor defective	Check for open or shorted motor winding. Replace motor.
	Motor capacitor defective	Check capacitor rating. Check for open or shorted capacitor. Replace capacitor.
Reversing valve does not energize (heating only)	Heat pump control defective	Check for 24V between RV-C and B-C. 1. Check control circuit wiring. 2. Replace heat pump control.
	Reversing valve solenoid coil defective	Check for open or shorted coil. Replace solenoid coil.
Unit will not go into defrost (heating only)	Temperature sensor or heat pump control defective	Disconnect temperature sensor from board and jumper across "SPEEDUP" terminals and "SEN JMP" terminals. This should cause the unit to go through a defrost cycle within one minute. 1. If unit goes through defrost cycle, replace temperature sensor. 2. If unit does not go through defrost cycle, replace heat pump control.
Unit will not come out of defrost (heating only)	Temperature sensor or heat pump control defective	Jumper across "SPEEDUP" terminal. This should cause the unit to come out of defrost within one minute. 1. If unit comes out of defrost cycle, replace temperature sensor. 2. If unit does not come out of defrost cycle, replace heat pump control.

## Checking Temperature Sensor Outside Unit Circuit

1. Disconnect temperature sensor from board and from outdoor coil.
2. Use an ohmmeter to measure the resistance of the sensor. Also use ohmmeter to check for short or open.
3. Check resistance reading to chart of resistance. Use sensor ambient temperature. (Tolerance of part is  $\pm 10\%$ .)
4. If sensor resistance reads very low, sensor is shorted and will not allow proper operation of the heat pump control.
5. If sensor is out of tolerance, shorted, open or reads very low ohms, it should be replaced.

**TABLE 9**  
**Temperature F vs. Resistance R of Temperature Sensor**

F	R	F	R	F	R	F	R
-25.0	196871	13.0	56985	53.0	19374	89.0	7507
-24.0	190099	14.0	55284	52.0	18867	90.0	7334
-23.0	183585	15.0	53640	53.0	18375	91.0	7165
-22.0	177318	16.0	52051	54.0	17989	92.0	7000
-21.0	171289	17.0	50514	55.0	17434	93.0	6840
-20.0	165487	18.0	49028	56.0	16984	94.0	6683
-19.0	159904	19.0	47590	57.0	16547	95.0	6531
-18.0	154529	20.0	46200	58.0	16122	96.0	6383
-17.0	149355	21.0	44855	59.0	15710	97.0	6239
-16.0	144374	22.0	43554	60.0	15310	98.0	6098
-15.0	139576	23.0	42295	61.0	14921	99.0	5961
-14.0	134956	24.0	41077	62.0	14544	100.0	5827
-13.0	130506	25.0	39898	63.0	14177	101.0	5697
-12.0	126219	26.0	38757	64.0	13820	102.0	5570
-11.0	122089	27.0	37652	65.0	13474	103.0	5446
-10.0	118108	28.0	36583	66.0	13137	104.0	5326
-9.0	114272	29.0	35548	67.0	12810	105.0	5208
-8.0	110575	30.0	34545	68.0	12492	106.0	5094
-7.0	107010	31.0	33574	69.0	12183	107.0	4982
-6.0	103574	32.0	32634	70.0	11883	108.0	4873
-5.0	100260	33.0	31723	71.0	11591	109.0	4767
-4.0	97064	34.0	30840	72.0	11307	110.0	4663
-3.0	93981	35.0	29986	73.0	11031	111.0	4562
-2.0	91008	36.0	29157	74.0	10762	112.0	4464
-1.0	88139	37.0	28355	75.0	10501	113.0	4367
0.0	85371	38.0	27577	76.0	10247	114.0	4274
1.0	82699	39.0	26823	77.0	10000	115.0	4182
2.0	80121	40.0	26092	78.0	9760	116.0	4093
3.0	77632	41.0	25383	79.0	9526	117.0	4006
4.0	75230	42.0	24696	80.0	9299	118.0	3921
5.0	72910	43.0	24030	81.0	9077	119.0	3838
6.0	70670	44.0	23384	82.0	8862	120.0	3757
7.0	68507	45.0	22758	83.0	8653	121.0	3678
8.0	66418	46.0	22150	84.0	8449	122.0	3601
9.0	64399	47.0	21561	85.0	8250	123.0	3526
10.0	62449	48.0	20989	86.0	8057	124.0	3452
11.0	60565	49.0	20435	87.0	7869		
12.0	58745	50.0	19896	88.0	7686		

## Troubleshooting ECM™ Indoor Blower Motors

**CAUTION:** Disconnect power from unit before removing or replacing connectors, or servicing motor. To avoid electric shock from the motor's capacitors, disconnect power and wait at least 5 minutes before opening motor.

Symptom	Cause/Procedure
Motor rocks slightly when starting	This is normal start-up for ECM
Motor won't start: No movement	Check blower turns by hand Check power at motor Check low voltage (24 Vac R to C) at motor Check low voltage connections (G, R, C) at motor Check for unseated pins in connectors on motor harness (see Table 10 on page 36) Test with a temporary jumper between R - G Check motor for tight shaft Perform motor/control replacement check Perform <b>Moisture Check</b>
Motor won't start: Motor rocks but won't start	Check for loose or compliant motor mount Make sure blower wheel is tight on shaft Perform motor/control replacement check
Motor oscillates up and down while being tested off of blower	It is normal for motor to oscillate with no load on shaft
Motor starts but runs erratically: Varies up or down or intermittent	Check line voltage for variation or "sag" Check low voltage connections (G, R, C) at motor, unseated pins in motor harness connectors Check out system controls, thermostat Perform <b>Moisture Check</b>
Motor starts but runs erratically: "Hunts" or "puffs"	Does removing panel or filter reduce "puffing"? - Reduce restriction
Motor starts but runs erratically: Blower won't shut off	Current leakage from controls into G, Y? - Check for Triac-switched thermostat or solid-state relay
Excessive noise	Determine if it's air noise, cabinet, duct or motor noise; interview customer, if necessary
Excessive noise: Air noise	High static creating high blower speed? - Is airflow set properly? - Does removing filter cause blower to slow down? Check filter - Use low-pressure drop filter - Check/correct duct restrictions
Excessive noise: Noisy blower or cabinet	Check for loose blower housing, panels, etc. High static creating high blower speed? - Check for air whistling through seams in ducts, cabinets or panels - Check for cabinet/duct deformation
Evidence of Moisture: Motor failure or malfunction has occurred and moisture is present	Replace motor and <b>Perform Moisture Check</b>
Evidence of Moisture: Evidence of moisture present inside air mover	Perform <b>Moisture Check</b>

Do's and Dont's	
Do	Don't
Check out motor, controls, wiring and connections thoroughly before replacing motor	Automatically assume motor is bad
Orient connectors down so water can't get in - Install "drip loops"	Locate connectors above 8 and 4 o'clock positions
Use authorized motor and model #s for replacement	Replace one motor or control model # with another (unless an authorized replacement)
Keep static pressure to a minimum: - Recommend high efficiency, low static filters - Recommend keeping filters clean - Design ductwork for minimum static, maximum comfort - Look for and recommend ductwork improvement, where necessary	Use high pressure drop filters—some have ½" H <sub>2</sub> O drop! Use restricted returns
Size equipment wisely	Oversize system then compensate with low airflow
Check orientation before inserting motor connectors	Plug in power connector backwards Force plug

### Moisture Check

- Connectors are oriented "down" (or as recommended by equipment manufacturer)
- Arrange harness with "drip loop" under motor
- Is condensate drain plugged?
- Check for low airflow (too much latent capacity)
- Check for undercharged condition
- Check and plug leaks in return ducts, cabinet

### Comfort Check

- Check proper airflow settings
- Low static pressure for lowest noise
- Thermostat in bad location?

**TABLE 10**  
**Troubleshooting ECM™ Indoor Blower Motors**

Mode of Operation	OFF	Continuous Blower (Ventilation Mode)	Full Load Cooling	Dehum. Mode (when equipped)	Full Load Heat Pump	Heat Pump Full Load w/ 1st Bank of Elec. Heat	Heat Pump Full Load w/ 1st & 2nd Bank of Elec. Heat	Emergency Heat Mode
Thermostat 24 VAC Input Signals	—	"G"	"G", "Y1", "Y2"	"D"	"G", "B", "Y1", "Y2"	"G", "Y1", "Y2", "B", "W1", "W2"	"G", "Y1", "Y2", "B", "W2", "W3"	"G", "W2", "W3"
Pin #1	24 VAC "C" (Common) Signal, Always Energized							
Pin #2						X		
Pin #3	24 VAC "C" (Common) Signal, Always Energized							
Pin #4	Not Used							
Pin #5	Not Used							
Pin #6			X	X	X	X	X	
Pin #7	Not Used							
Pin #8	Not Used							
Pin #9					X	X	X	
Pin #10		X	X	X	X	X	X	X
Pin #11	Not Used							
Pin #12	24 VAC Hot "R" Signal, Always Energized							
Pin #13						X	X	X
Pin #14			X		X	X	X	
Pin #15		X	X	X	X	X	X	X
Pin #16	Not Used							

**FIGURE 11 – Control Connector Motor Half**

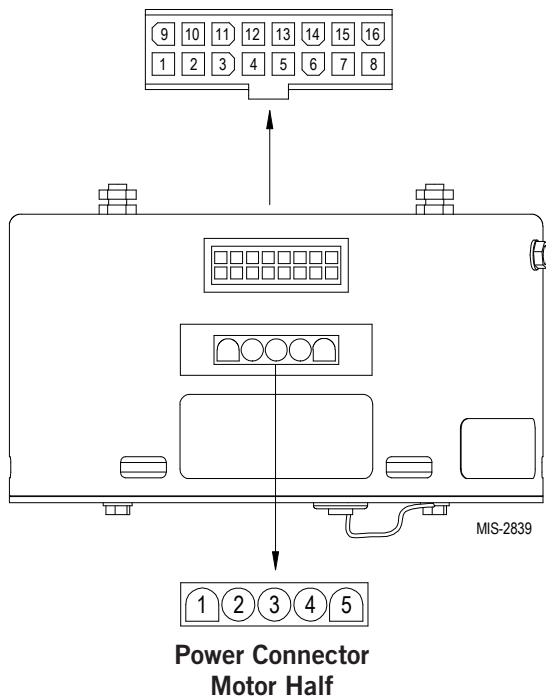

POWER CONNECTOR	
PWB HEADER	AMP 1-350945-0
PIN	Description
1	Jumper Pin 1 to Pin 2 for 120VAC Line Input Only **
2	
3	Chassis Ground
4	AC Line
5	AC Line

\* Suggested mating connector  
Housing – AMP 350809-1  
Contact – AMP 350537-1

\*\* **WARNING: Applying 240VAC line input with PIN 1 to PIN 2 jumper in place will permanently damage unit!**

## Refrigerant Leak Detection System (RDS)

This unit is equipped with a refrigerant leak detection system (RDS). This system monitors the air in the indoor section of the unit for refrigerant leaks. In the event of a leak, the RDS will enter mitigation mode, which prohibits function of the compressor and electric heaters (if applicable) and turns on the indoor blower in order to prevent the refrigerant from concentrating within the unit. The RDS is made up of three major components: Refrigerant sensor, RDS harness and DPDT relay (see Figure 12).

### Why RDS?

R-454B refrigerant carries an "A2L" safety classification, meaning it is mildly flammable in certain concentrations. The purpose of the RDS is to prevent refrigerant from reaching potentially dangerous concentrations within the indoor section of the unit in the event of a refrigerant leak.

### Sequence of Operations

The refrigerant sensor has four operating modes: Power up and self test, normal, alarm state and sensor fault. During all modes of operation the sensor will continue to perform runtime diagnostics.

### Power Up and Self Test

When the air conditioner receives power, the refrigerant sensor executes a series of self test diagnostics. This validates the integrity of the sensor's memory, embedded program, and power supply. This power up sequence only takes a few seconds.

### Normal Operation

Once the refrigerant sensor's power up sequence is complete, the RDS begins normal operation. In this mode the refrigerant sensor is active and the air conditioner functions normally.

### Alarm State

The refrigerant sensor has a factory-set alarm threshold limit value. When the sensor registers refrigerant at a concentration above this threshold, the sensor enters alarm state. In alarm state the internal relay within the refrigerant sensor is de-energized, which puts the RDS into mitigation mode.

### Sensor Fault Mode

The refrigerant sensor performs continuous diagnostics on the sensor integrity (shorts, opens, out of range, communication errors) as well as the integrity of the on-board memory, programming, oscillator and voltage

**FIGURE 12**  
**Refrigerant Leak Detection System**

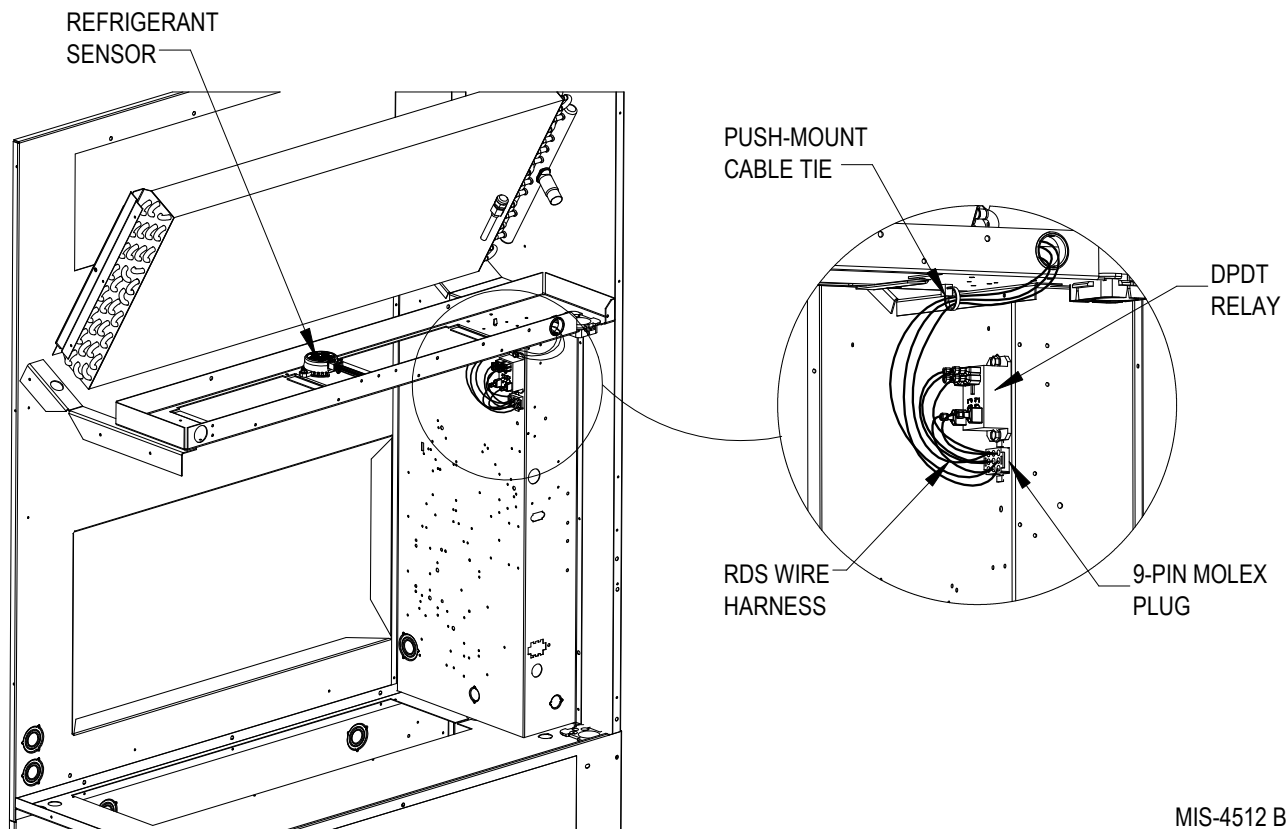

MIS-4512 B

levels. If any of these diagnostics fail or the sensor becomes disconnected, the internal relay within the refrigerant sensor is de-energized, which puts the RDS into mitigation mode.

### Mitigation Mode

When the RDS enters mitigation mode, it initiates the following:

- The "G" terminal is energized on the low voltage terminal strip. This activates the indoor blower.
- The signal from "CC" on the defrost board to the compressor contactor is interrupted. This stops compressor operation or prevents it from starting in the event of a call from the thermostat
- The 24V common connection to all electric heat contactors (if applicable) is broken. This stops electric heat operation or prevents it from starting in the event of a heating call
- The "L" terminal on the low voltage terminal strip is energized. This output may be used to trigger an external alarm or notify a building management system or group controller that a leak has occurred.

### Alarm Reset





The refrigerant sensor will stay in alarm mode as long as the refrigerant concentration remains above the alarm threshold limit value. For the alarm to be reset, the sensor reading must be a minimum of 2.5% below the alarm threshold for a period of 5 minutes. The relay is then re-energized, and the unit returns to normal operation.

### RDS Diagnosis

The refrigerant sensor of the RDS features a status LED. When the sensor is powered up, an LED will indicate sensor status. The sensor LED will back-light the sensor and create a visible reflection on the blower partition. Status LED blink codes shown in Figure 13.

**NOTE:** *If the sensor status LED is not lit, the sensor is either not receiving power or may be faulty or damaged. Check harness connections and test internal relay. Refer to A2L Safety Manual 2100-810 for additional diagnostic information.*

**FIGURE 13**  
**Sensor Status LED Blink Code**

-  Solid Green: Sensor Power Up and Self Test
-  Blinking Green: Normal Operation
-  Solid Red: Alarm State – Gas Detection
-  Blinking Red: Sensor Fault

## **WARNING**

***The Refrigerant Leak Detection System (RDS) is a safety device. Do not disable.***

### Sensor End-of-Life

The refrigerant sensor has a rated life expectancy of 15+ years. This is not a set time length, but it is the expected time that the sensor should last without failing its internal checks. In the event that the sensor would reach its end-of-life, it will enter Sensor Failure Mode and the sensor will need to be replaced. **The sensor must be replaced with a Bard-approved refrigerant sensor.** See unit replacement parts manual for the correct replacement sensor information.

**FIGURE 14**  
**Refrigerant Leak Detection System (RDS) Troubleshooting**

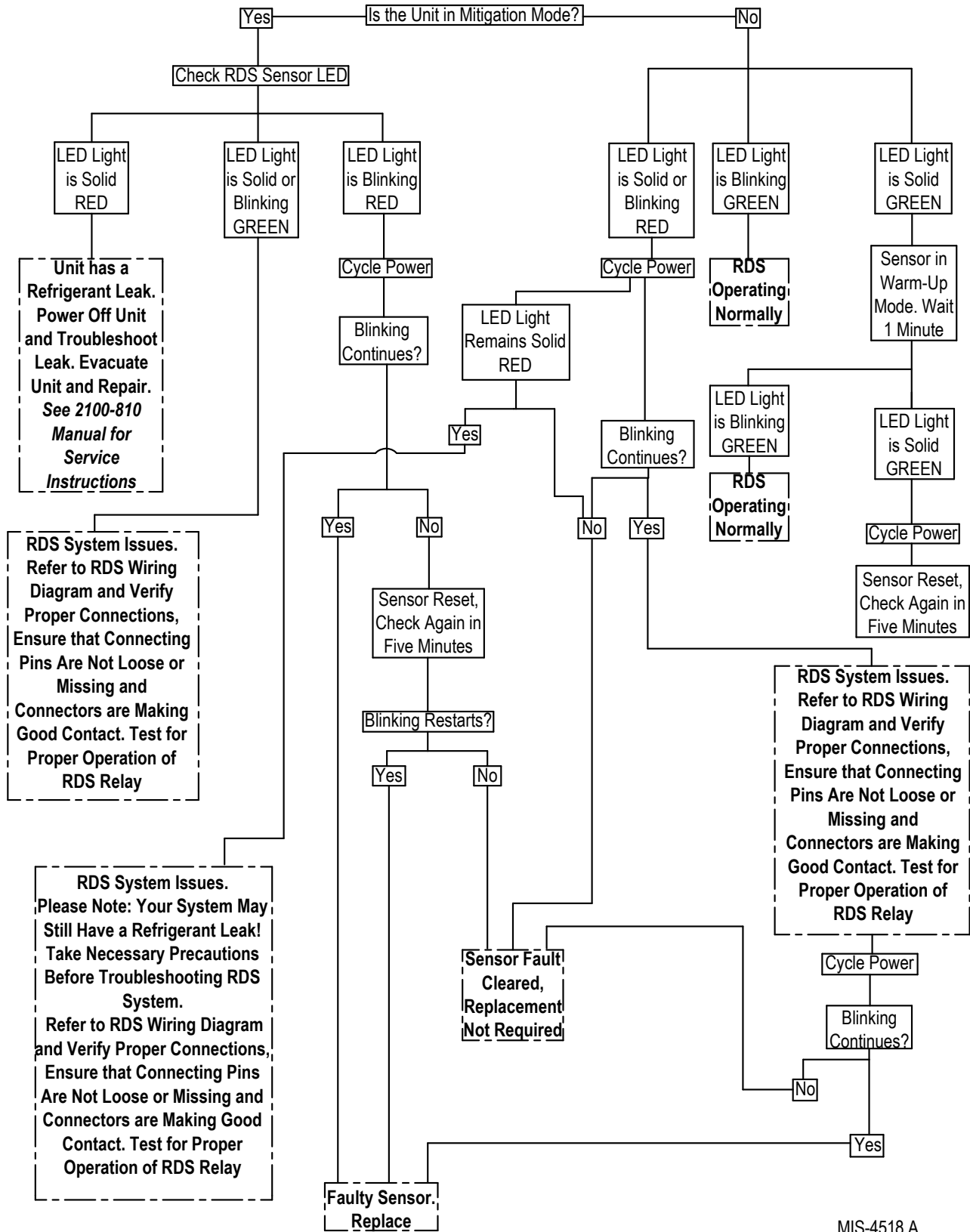

MIS-4518 A

**FIGURE 15**  
**Refrigerant Leak Detection System (RDS) Wiring Diagram**

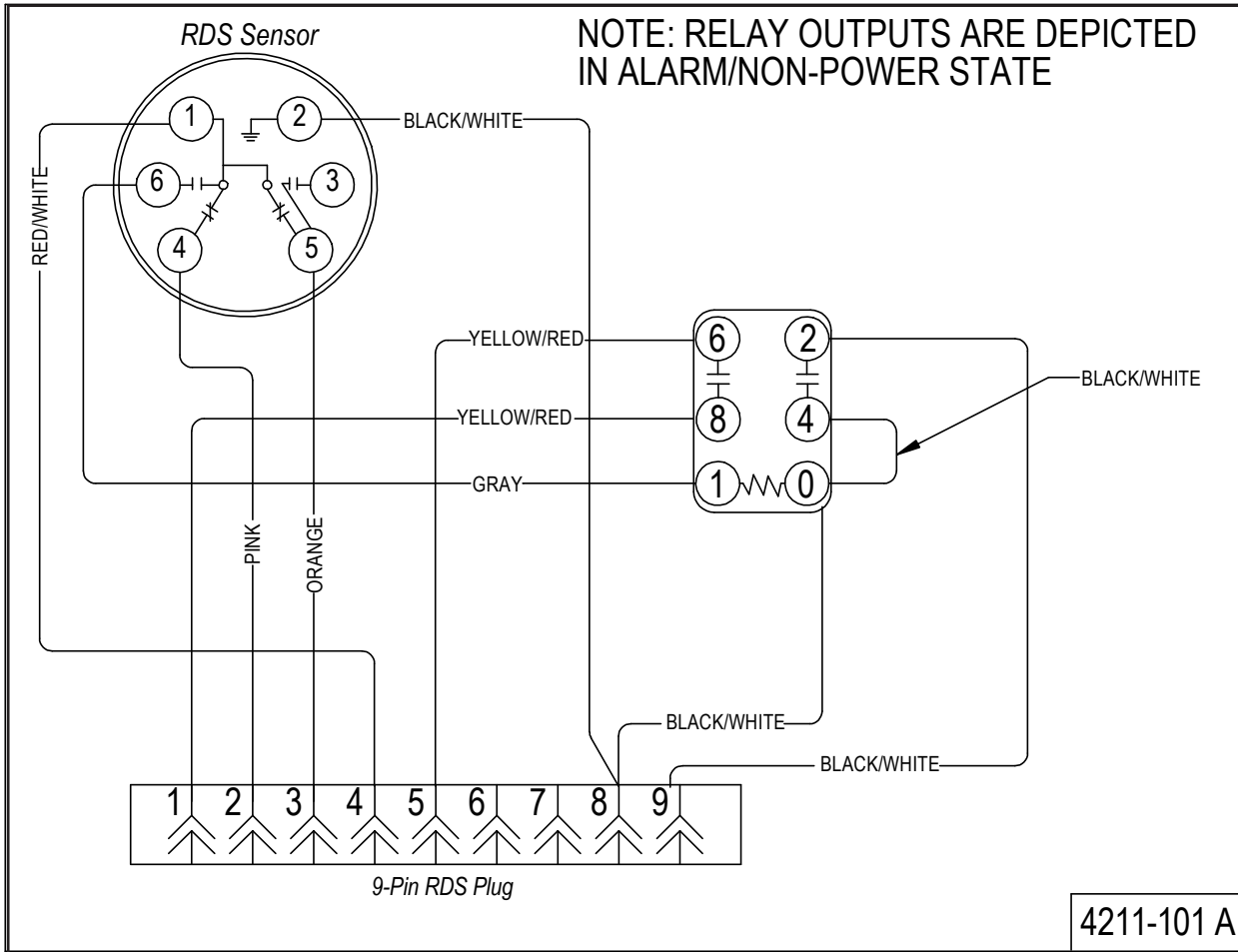

## Fan Blade Setting Dimensions

The correct fan blade setting for proper air delivery across the outdoor coil is shown in Figure 16. Refer to Table 11 for unit specific dimension.

Any service work requiring removal or adjustment in the fan and/or motor area will require that the dimensions below be checked and blade adjusted in or out on the motor shaft accordingly.

**FIGURE 16**  
Fan Blade Setting

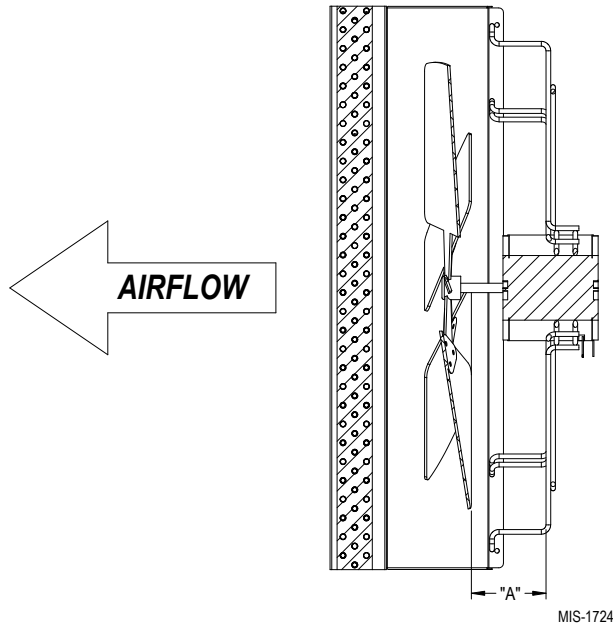

**TABLE 11**  
Fan Blade Dimension

Model	Dimension A
C24HF C30HF	1.25"

\* "A" dimension is measured at the closest part of the fan blade

## Removal of Fan Shroud

1. Disconnect all power to the unit.
2. Remove the screws holding both grilles, one on each side of unit, and remove grilles.
3. Remove nine screws holding fan shroud to condenser and bottom.
4. Unwire condenser fan motor.
5. Slide complete motor, fan blade and shroud assembly out the left side of the unit.
6. Service motor/fan as needed.
7. Reverse steps to re-install.

## R-454B Refrigerant Charge

This unit was charged at the factory with the quantity of refrigerant listed on the serial plate. AHRI capacity and efficiency ratings were determined by testing with this refrigerant charge quantity.

The pressure tables on the following pages show nominal pressures for the units. Since many installation specific situations can affect the pressure readings, this information should only be used by certified technicians as a guide for evaluating proper system performance. They shall not be used to adjust charge. If charge is in doubt, recover, evacuate and recharge the unit to the serial plate charge.

**TABLE 12A**  
**Cooling Pressures – Rated Airflow**

Air Temperature Entering Outdoor Coil °F

Model	Return Air Temp (DB/WB)	Pressure	Air Temperature Entering Outdoor Coil °F										
			75	80	85	90	95	100	105	110	115	120	125
C24HF	75/62	Suction Pressure	122	125	127	129	131	132	133	134	134	134	133
		Head Pressure	270	290	311	333	356	379	404	430	456	484	512
	80/67	Suction Pressure	130	133	136	138	140	142	143	143	144	143	143
		Head Pressure	277	297	319	341	365	389	414	441	468	496	526
	85/72	Suction Pressure	135	138	141	143	145	147	148	148	149	148	148
		Head Pressure	286	308	330	353	378	403	429	456	484	514	544
C30HF	75/62	Suction Pressure	121	122	122	123	124	125	126	128	129	131	132
		Head Pressure	286	306	327	349	373	397	423	450	479	508	539
	80/67	Suction Pressure	129	130	131	132	133	134	135	137	138	140	142
		Head Pressure	293	313	335	358	382	408	434	462	491	521	553
	85/72	Suction Pressure	134	134	135	136	137	139	140	141	143	145	147
		Head Pressure	303	324	347	371	396	422	449	478	508	539	572

Low side pressure ± 4 PSIG  
High side pressure ± 10 PSIG

Tables are based upon rated CFM (airflow) across the evaporator coil. If there is any doubt as to correct operating charge being in the system, the charge should be removed and system evacuated and recharged to serial plate charge weight.

**NOTE:** Pressure table based on high speed condenser fan operation. If condensing pressures appear elevated check condenser fan wiring. See **Condenser Fan Operation** on page 29.

**TABLE 12B**  
**Cooling Pressures – Part Load Airflow**

Air Temperature Entering Outdoor Coil °F

Model	Return Air Temp (DB/WB)	Pressure	Air Temperature Entering Outdoor Coil °F										
			75	80	85	90	95	100	105	110	115	120	125
C24HF	75/62	Suction Pressure	127	129	130	131	132	133	135	136	137	139	140
		Head Pressure	212	247	266	286	307	329	351	374	398	423	449
	80/67	Suction Pressure	136	138	139	140	141	143	144	146	147	149	150
		Head Pressure	217	254	273	294	315	337	360	384	409	434	460
	85/72	Suction Pressure	140	143	144	145	146	148	149	151	152	154	156
		Head Pressure	225	263	283	304	326	349	373	397	423	449	477
C30HF	75/62	Suction Pressure	119	123	124	126	127	129	130	130	131	131	132
		Head Pressure	226	260	279	298	319	341	364	388	414	440	467
	80/67	Suction Pressure	127	131	133	135	136	137	139	139	140	141	141
		Head Pressure	232	267	286	306	327	350	374	398	424	451	479
	85/72	Suction Pressure	132	136	138	140	141	142	143	144	145	145	146
		Head Pressure	240	276	296	317	339	362	387	412	439	467	496

Low side pressure ± 4 PSIG  
High side pressure ± 10 PSIG

Tables are based upon rated CFM (airflow) across the evaporator coil. If there is any doubt as to correct operating charge being in the system, the charge should be removed and system evacuated and recharged to serial plate charge weight.

**NOTE:** Pressure table based on high speed condenser fan operation. If condensing pressures appear elevated check condenser fan wiring. See **Condenser Fan Operation** on page 29.

**TABLE 13A**  
**Heating Pressures – Rated Airflow**

Model	Return Air Temp (DB)	Pressure	Air Temperature Entering Outdoor Coil °F													
			0	5	10	15	20	25	30	35	40	45	50	55	60	65
C24HF	70	Suction Pressure	29	36	43	50	58	65	73	82	90	99	109	118	128	138
		Head Pressure	260	268	275	283	291	300	308	317	326	335	345	355	364	375
C30HF	70	Suction Pressure	31	37	43	49	56	63	70	78	86	94	102	111	120	129
		Head Pressure	264	272	281	289	298	308	317	327	337	347	358	369	380	391

**TABLE 13B**  
**Heating Pressures – Part Load Airflow**

Model	Return Air Temp (DB)	Pressure	Air Temperature Entering Outdoor Coil °F													
			0	5	10	15	20	25	30	35	40	45	50	55	60	65
C24HF	70	Suction Pressure	29	36	43	50	58	66	75	84	94	104	114	125	136	148
		Head Pressure	256	262	269	277	284	292	301	309	318	328	337	347	358	369
C30HF	70	Suction Pressure	36	41	47	53	60	67	75	83	91	100	110	120	130	141
		Head Pressure	247	255	263	272	281	291	301	311	321	332	344	355	367	380

**TABLE 14**  
**Electrical Specifications**

Model	Rated Volts & Phase	No. Field Power Circuits	Single Circuit		Dual Circuit			
			① Minimum Circuit Ampacity	② Maximum External Fuse or Circuit Breaker	① Minimum Circuit Ampacity		② Maximum External Fuse or Circuit Breaker	
					Ckt. A	Ckt. B	Ckt. A	Ckt. B
C24HF-A00, A0Z A04 A08	230/208-1	1 1 1	18 39 60	25 40 60				
C24HF-B00, B0Z B05 B09	230/208-3	1 1	13 28 40	15 30 40				
C24HF-C00, C0Z C05	460-3	1 1	8 15	15 15				
C30HF-A00, A0Z A04 A08	230/208-1	1 1 1 or 2	24 45 65	30 45 70	24	42	30	45
C30HF-B00, B0Z B05 B09	230/208-3	1 1 1	15 30 43	20 30 45				
C30HF-C00, C0Z C05 C09	460-3	1 1 1	9 17 23	15 20 25				

① These “Minimum Circuit Ampacity” values are to be used for sizing the field power conductors. Refer to the National Electrical code (latest version), Article 310 for power conductor sizing. **CAUTION:** When more than one field power circuit is run through one conduit, the conductors must be derated. Pay special attention to note 8 of Table 310 regarding Ampacity Adjustment Factors when more than three (3) current carrying conductors are in a raceway.

② Maximum size of the time delay fuse or circuit breaker for protection of field wiring conductors.

**NOTE:** The Maximum Overcurrent Protection (MOCP) value listed is the maximum value as per UL 60335 calculations for MOCP (branch-circuit conductor sizes in this chart are based on this MOCP). The actual factory-installed overcurrent protective device (circuit breaker) in this model may be lower than the maximum UL 60335 allowable MOCP value, but still above the UL 60335 minimum calculated value or Minimum Circuit Ampacity (MCA) listed.

**IMPORTANT:** While this electrical data is presented as a guide, it is important to electrically connect properly sized fuses and conductor wires in accordance with the National Electrical Code and all local codes.

## Unit Airflow

These units are equipped with a variable speed (ECM) indoor motor that automatically adjusts itself to maintain approximately the same rate of indoor airflow in both heating and cooling, dry and wet coil conditions and at both 230/208 or 460 volts.

An additional feature of the system is the possibility to reduce the airflow by 10%. This can be accomplished by disconnection of blower motor low voltage wire coming from PIN 10 and connected to the "R" terminal of the defrost board. If this wire is disconnected, use electrical tape to cover end of connector to prevent short-circuiting. The 10% reduction will only be adjusted when unit is running in cooling mode. In heating mode the blower will remain at rated airflow.

**TABLE 15**  
**Indoor Airflow Status and Unit Performance**

Model	Rated ESP	Maximum ESP ①	Blower Only ② ③	Part Load/ Dehum CFM ④	Full Load CFM ④	Electric Heat ④
C24HF	0.15	0.50	545	545	750	750
C30HF	0.15	0.50	650	650	900	900

**NOTE:** These units are equipped with a variable speed (ECM) indoor motor that automatically adjusts itself to maintain approximately the same rate of indoor airflow in both heating and cooling, dry and wet coil conditions and at both 230/208 or 460 volts.

- ① Maximum ESP (inches WC) shown is with 2" thick disposable filter.
- ② Blower-only CFM is the total air being circulated during continuous fan mode. Airflow remains constant.
- ③ Blower-only CFM reduces during continuous fan mode. Requires wiring modification; consult installation instructions and wiring diagram.
- ④ CFM output on cooling or electric heat.

## Dirty Filter Switch

1. Disconnect all power to the unit. Remove control panel outer cover and upper front panel.
2. The dirty filter switch is located on top of the filter partition to the right of the blower wheels (see Figure 17). The dirty filter indicator light and reset switch is attached to the side of the control panel on the right side of the filter access opening. Remove the cover on the dirty filter switch and ensure the knob is set at 0.4" W.C. (see Figure 18). This is only a recommended starting point prior to making switch adjustments. Switch setting is highly dependent on filter type used, blower speed, unit ducting and other unit installation characteristics. See **Dirty Filter Switch Adjustment** for instructions on how to make proper switch adjustments.
3. Re-install upper front panel.

### Dirty Filter Switch Adjustment

1. Apply power to the unit.
2. Turn the unit indoor blower on (energize R-G on low voltage terminal board).

3. With air filters installed and switch initially set at 0.4" W.C. (see Step 2 under **Dirty Filter Switch**), begin restricting the air filter of the unit using a piece of cardboard under the filters until the switch trips and the light comes on. If the filter is restricted by 75% (or desired restriction amount), skip to Step 6.
4. If switch setting adjustment is required, disconnect power to the unit. Remove the upper front panel and the cover on the airflow switch so that adjustment can be made. If the switch tripped before 75% restriction was reached, turn the knob slightly clockwise. If the switch tripped after 75%, turn the knob counter-clockwise (see Figure 18).
5. Replace the upper front panel and repeat Steps 1-3. Continue to make adjustments described in Step 4 until the desired restriction is obtained.
6. Remove the restriction and reset the filter switch. Replace the switch cover once adjustment is complete.
7. Install the outer control panel cover. This completes the adjustment.

**FIGURE 17**  
Dirty Filter Switch Location

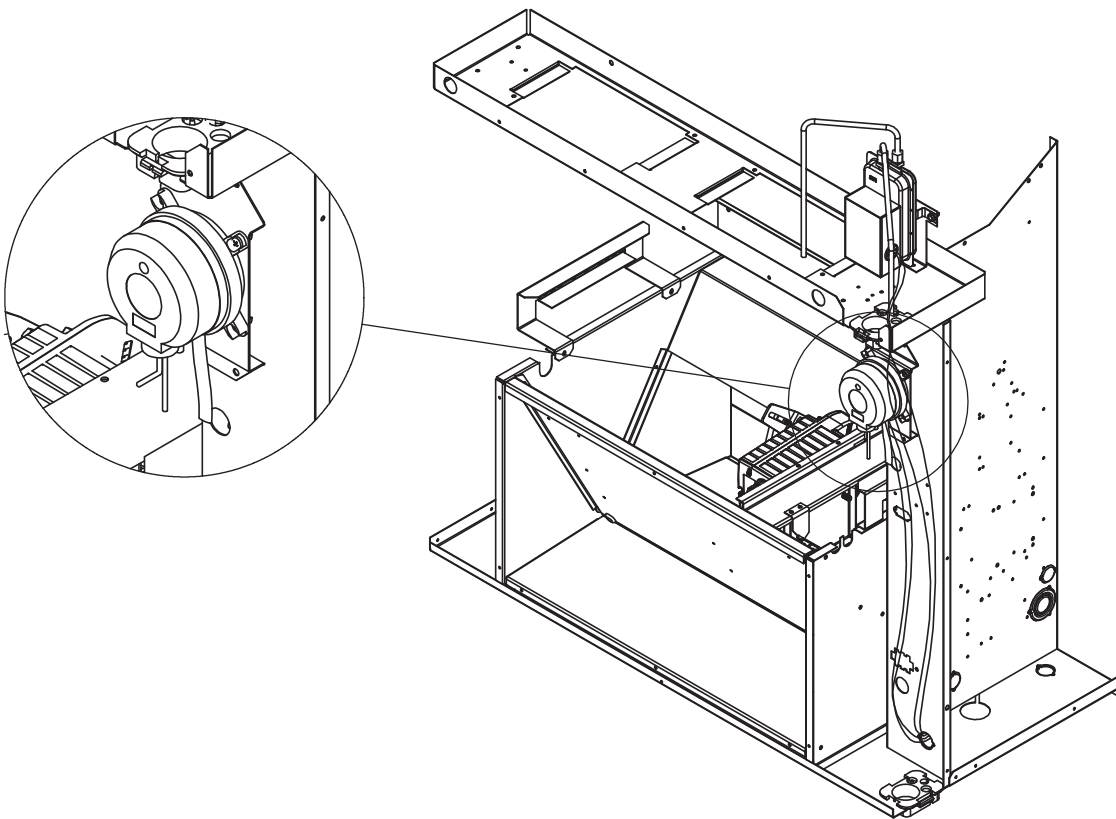

**FIGURE 18**  
**Adjusting Dirty Filter Switch**

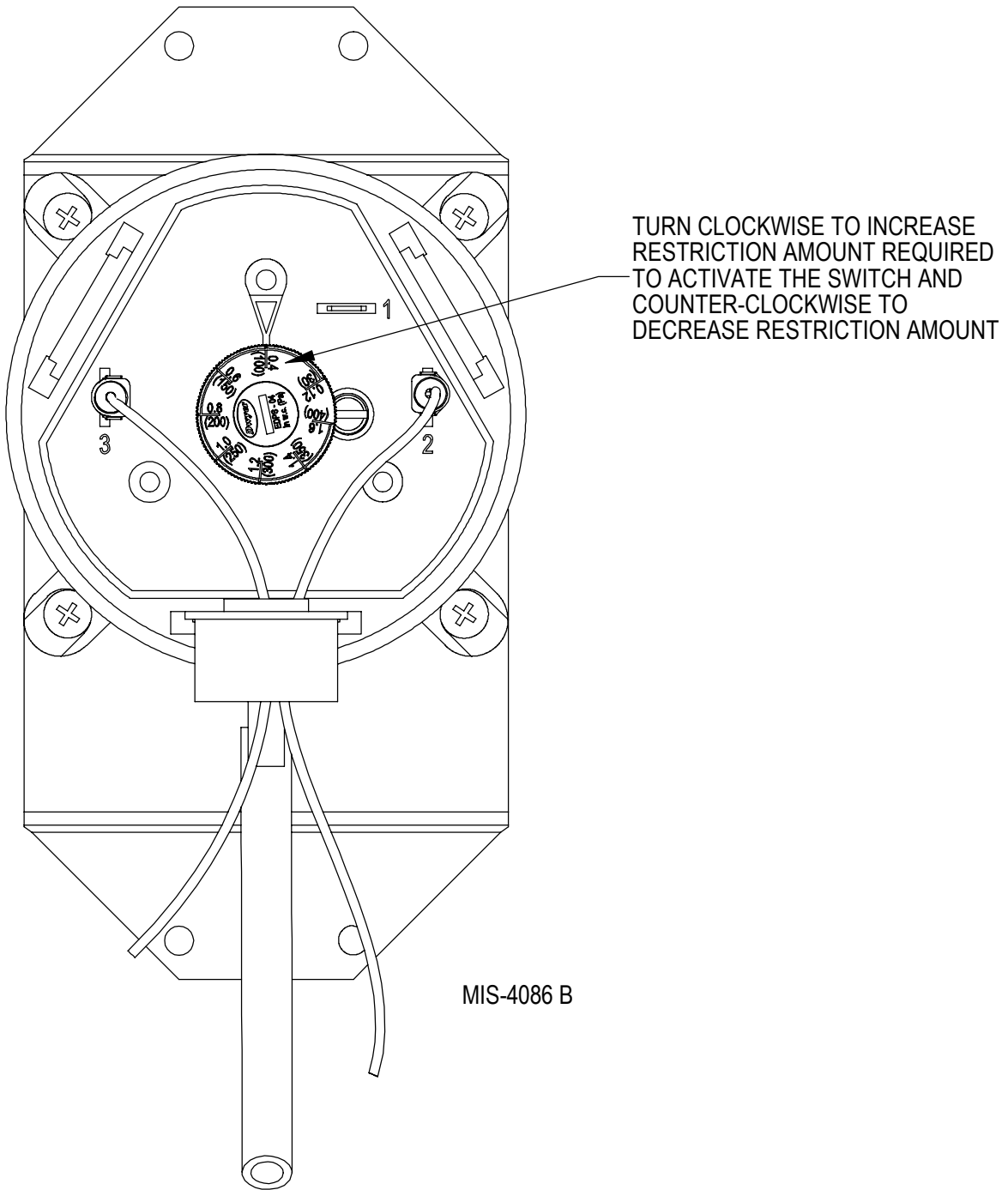

**TABLE 16**  
**Maximum ESP of Operation**  
**Electric Heat Only**

Model	C24HF	C30HF
-A04	.50	.50
-A08	.50	.50
-B05	.50	.50
-B09	.50	.50
-C05	.50	.50
-C09	.50	.50

Values shown are for units equipped with 2" pleated MERV 13 filter.

**TABLE 17**  
**Electric Heat**

Electric Heat Nomenclature	Nominal KW	Total KW and BTUH @ Field-Supplied Voltage										
		@ 230V (1)				@ 208V (1)				@ 460V		
		KW	1 PH Amps	3 PH Amps	BTUH	KW	1 PH Amps	3 PH Amps	BTUH	KW	3 PH Amps	BTUH
		4	4	3.7	16		12,600	3.0	14.4		10,200	
5	5	4.6	20	11.5	15,700	3.8	18	10.4	12,800	4.6	5.8	15,700
8	8	7.4	32		25,100	6.0	28.8		20,500			
9	9	8.3		20.8	28,300	6.8		18.7	23,000	8.3	10.4	28,300

**TABLE 18**  
**Optional Accessories**

Part Number	C24HF-A	C24HF-B	C24HF-C	C24HFDA	C24HFDB	C24HFDC	C30HF-A	C30HF-B	C30HF-C	C30HFDA	C30HFDB	C30HFDC
	<b>Heater Kits</b>											
EHCH024A-A04	X			X								
EHCH024A-A08	X			X								
EHCH024A-B05					X							
EHCH024A-B09		X			X							
EHCH030A-A04							X					
EHCH030A-A08							X			X		
EHCH030A-B05								X				
EHCH030A-B09								X			X	
EHCH030ADA04										X		
EHCH030ADB05											X	
EHCH030ADC09												X
EHWH024A-B05		X										
EHWH030A-C05			X			X			X			X
EHWH030A-C09									X			
<b>Circuit Breaker (WMCB) &amp; Pull Disconnect (WMPD)</b>												
WMCB-01B		X			X							
WMPD-01C			X			X			X			X
WMCB-02B								X			X	
WMCB-03A	X			X								
WMCB-04A							X			X		

**TABLE 19**  
**Vent and Control Options**

<b>Part Number</b>	<b>Description</b>	<b>C24HF C30HF</b>
CMC-15	Start Relay (PTCR based) ①	X
CMC-31	Dirty Filter Sensor Kit	X
CMC-34	Alarm Relay	X
CMC-36	Crankcase Heater – 230V	X
CMC-37	Crankcase Heater – 460V	X
CMH-28	Outdoor Thermostat – Heat Pump (ODT)	X
CMH-42	Low Ambient Control – Heat Pump (LAC)	X
SK-111	Start Kit (Hard Start) ②	X
BOP3	Blank-Off Plate	X
FAD-NE3	Fresh Air Damper – No Exhaust	X
FAD-BE3	Fresh Air Damper – Barometric Exhaust	X
CRV-F3-*	Commercial Ventilator – On/Off, Spring Return	X
CRV-V3-*	Commercial Ventilator – 0-10V, Spring Return	X
ECON-NC3A-*	Economizer – Bldg. Equipment, 0-10V, No Controls	X
ECON-S3-*	Economizer – School	X
ECON-WD3A-*	Economizer – Bldg. Equipment, Enthalpy	X
ECON-DB3A-*	Economizer – Bldg. Equipment, Temperature	X
ERV-FA3-*	Energy Recovery Ventilator (230V)	X
ERV-FC3-*	Energy Recovery Ventilator (460V)	X

\* Insert color to match unit (X = Beige, 1 = White, 4 = Gray, 5 = Desert Brown, 8 = Dark Bronze, S = Stainless, A = Aluminum)

- ① PTCR Start Kit can be used with all -A single phase models. Increases starting torque 2-3x. Not used for -B or -C three phase models. Do not use if SK111 is used.
- ② Start capacitor and potential relay start kit can be used with all -A single phase models. Increases starting torque 9x. Not used for -B or -C three phase models. Do not use if CMC-15 is used.

**GRAPH 1**  
**C24-30H Fresh Air Damper Ventilation Delivery**

