

---

# REPLACEMENT PARTS MANUAL

---

## WALL MOUNTED PACKAGED HEAT PUMP

Models:

W18HA-A    W24HA-A    W24HADA  
                  W24HA-B    W24HADB  
                  W24HA-C    W24HADC

---

### Contents

Description	Page	Description	Page
Cabinet Components		Control Panel – 460 Volt 3 Phase Units	
♦ Exploded View .....	2	♦ Layout View .....	12
♦ Usage List .....	3	♦ Usage List .....	13
Functional Components – Standard Units		Blower Assembly	
♦ Exploded View .....	4	♦ Exploded View .....	14
♦ Usage List .....	5	♦ Usage List .....	14
Functional Components – Dehumidification Units			
♦ Exploded View .....	6		
♦ Usage List .....	7		
Control Panel – 230 Volt 1 Phase Units			
♦ Layout View .....	8		
♦ Usage List .....	9		
Control Panel – 230 Volt 3 Phase Units			
♦ Layout View .....	10		
♦ Usage List .....	11		

### General Notes

- Revised and/or additional pages may be issued from time to time.
- A complete and current manual consists of pages shown in the following contents section.

### Important

- Contact the installing and/or local Bard distributor for all parts requirements. Make sure you have the complete model and serial number available from the unit rating plates.



Bard Manufacturing Company, Inc.  
Bryan, Ohio 43506  
www.bardhvac.com

Manual: 2110-1532A  
Supersedes: 2110-1532  
Date: 5-4-16

# CABINET COMPONENTS

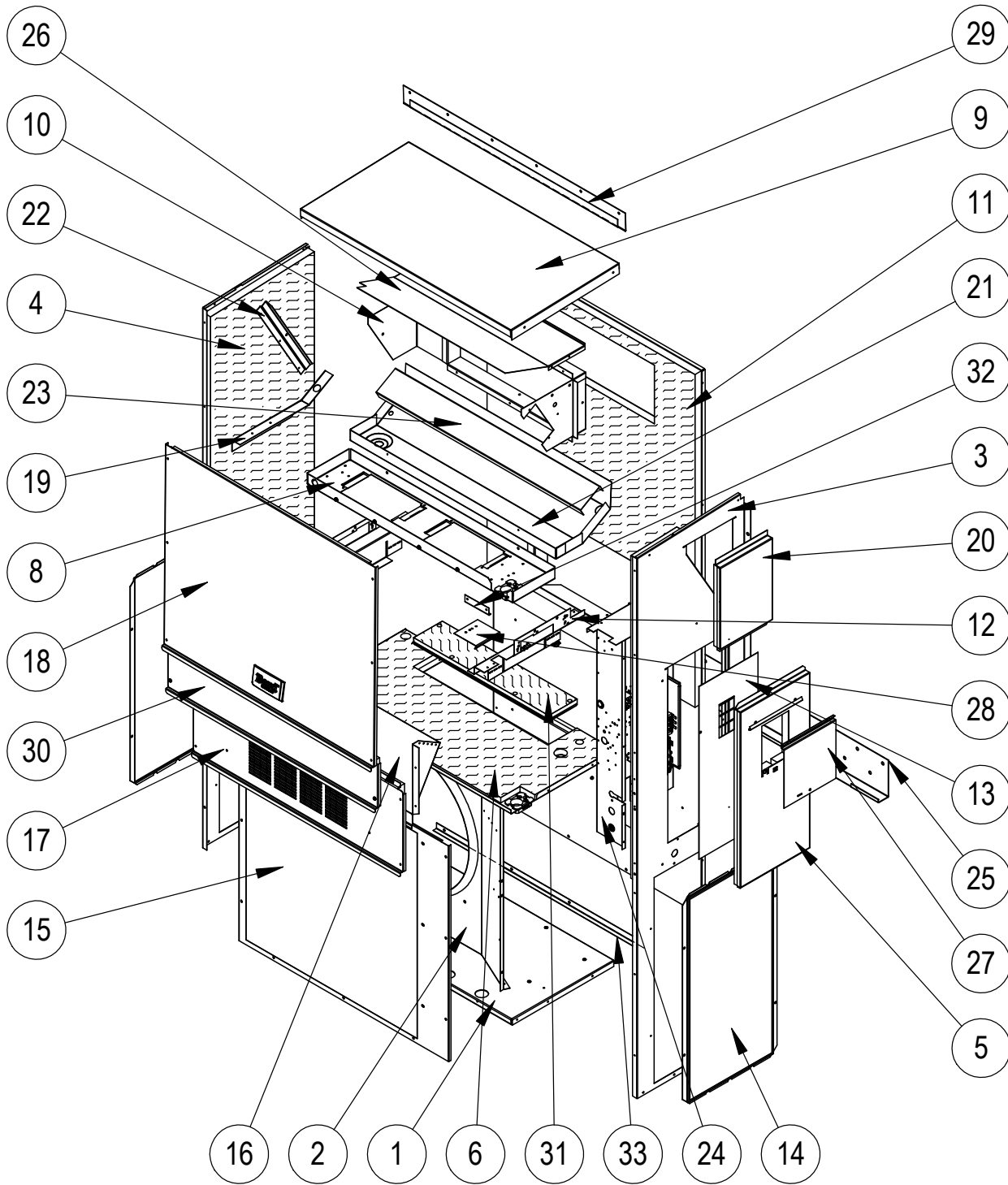

SEXP-804

# CABINET COMPONENTS

Dwg No.	Part Number	Description	W18HA-A	W24HA-A, B	W24HA-C	W24HADA, B	W24HADC
1	127-467	Lower Base	X	X	X	X	X
1	127-469 ②	Lower Base	X	X	X	X	X
2	125-080	Fan Shroud	X	X	X	X	X
2	125-082 ②	Fan Shroud	X	X	X	X	X
3	S501-933-* ①	Right Side	X	X	X	X	X
3	S501-939-* ②	Right Side	X	X	X	X	X
3	S501-937 ③	Right Side	X	X	X	X	X
4	S501-934-* ①	Left Side	X	X	X	X	X
4	S501-938-* ②	Left Side	X	X	X	X	X
4	S501-940 ③	Left Side	X	X	X	X	X
5	S533-228-* ①	Control Panel Cover (Outer)	X	X	X	X	X
5	S533-235 ②	Control Panel Cover (Outer)	X	X	X	X	X
5	S533-236 ③	Control Panel Cover (Outer)	X	X	X	X	X
6	S521X528	Condenser Partition	X	X	X	X	X
8	121X480	Blower Partition	X	X	X	X	X
9	S507-311-* ①	Top	X	X	X	X	X
9	S507-318-* ③	Top	X	X	X	X	X
9	S507-317 ②	Top	X	X	X	X	X
10	S111X032	Outlet Air Frame Assembly	X	X	X	X	X
11	S508-342	Back	X	X	X	X	X
11	S508-344 ③	Back	X	X	X	X	X
11	S508-346 ②	Back	X	X	X	X	X
12	113X480	Filter Bracket	2	2	2	2	2
13	S132-104	Control Panel Cover (Inner)	X	X		X	
13	S132-172	Control Panel Cover (Inner)			X		X
14	118-105-* ①	Side Grille	2	2	2	2	2
14	118-110 ②	Side Grille	2	2	2	2	2
14	118-115 ③	Side Grille	2	2	2	2	2
15	118-101-* ①	Condenser Grille	X	X	X	X	X
15	118-106 ②	Condenser Grille	X	X	X	X	X
15	118-111 ③	Condenser Grille	X	X	X	X	X
16	BFAD-2	Fresh Air Damper Assembly	X	X	X	X	X
17	S553-537-* ①	Vent Option Door	X	X	X	X	X
17	S553-548 ③	Vent Option Door	X	X	X	X	X
17	S553-555-* ②	Vent Option Door with ERV	X	X	X	X	X
17	S553-539 ①	Vent Option Door with ERV	X	X	X	X	X
17	S553-556 ③	Vent Option Door with ERV	X	X	X	X	X
17	S553-547 ②	Vent Option Door	X	X	X	X	X
18	S514-240-* ①	Upper Front	X	X	X	X	X
18	S514-237-* ③	Upper Front	X	X	X	X	X
18	S514-236 ②	Upper Front	X	X	X	X	X
19	105X850	Side Support	X	X	X	X	X
20	S543-175-* ①	Right Side Cover Plate (Outer)	X	X	X	X	X
20	S543-185 ②	Right Side Cover Plate (Outer)	X	X	X	X	X
20	S543-184 ③	Right Side Cover Plate (Outer)	X	X	X	X	X
21	S123-126	Drain Pan	X	X	X	X	X
21	S123-140 ②③	Drain Pan	X	X	X	X	X
22	147-044	Evaporator Support	X	X	X	X	X
23	137-694	Bottom Evaporator Fill	X	X	X		
23	137-195	Bottom Evaporator Fill				X	X
24	Control Panel Assembly	See Control Panel Assy. Drawing & Parts List Assy.	X	X	X	X	X
25	113-140	Bottom Mounting Bracket	X	X	X	X	X
26	135X127	Heat Shield	X	X	X	X	X
27	S153-218 ①	Disconnect Access Door	X	X	X	X	X
27	S153-405 ②	Disconnect Access Door	X	X	X	X	X
27	S153-387 ③	Disconnect Access Door	X	X	X	X	X
28	137-259	Fill Plate	X	X	X	X	X
29	113-141-* ①	Top Rain Flashing	X	X	X	X	X
29	113-361 ②	Top Rain Flashing	X	X	X	X	X
29	113-141-4 ③	Top Rain Flashing	X	X	X	X	X
30	S553-538-* ①	Filter Door	X	X	X	X	X
30	S553-552-* ③	Filter Door	X	X	X	X	X
30	S553-551 ②	Filter Door	X	X	X	X	X
31	S536-176	Cond. Partition Block Off Plate	X	X	X	X	X
32	105-1302	Grommet Retainer	X	X	X	X	X
33	105-1392	Close Off Angle	X	X	X	X	X

① Exterior cabinet parts are manufactured with various paint color options. To ensure the proper paint color is received, include the complete model and serial number of the unit for which cabinet parts are being ordered.

② Exterior cabinet parts are manufactured from stainless steel Code "S"

③ Exterior cabinet parts are manufactured from aluminum Code "A"

# FUNCTIONAL COMPONENTS - STANDARD UNITS

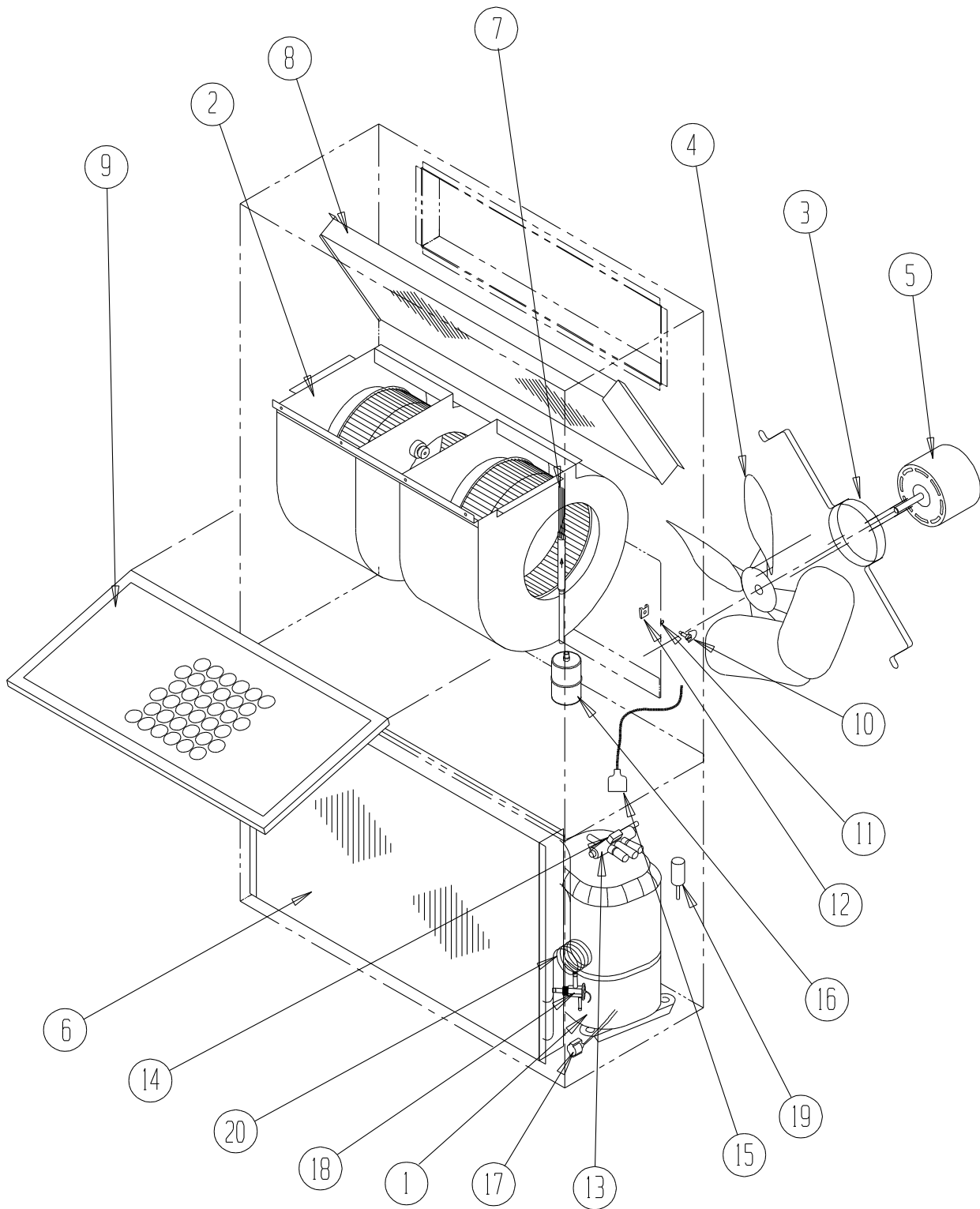

SEXP-529

## FUNCTIONAL COMPONENTS – STANDARD UNITS

Dwg No.	Part Number	Description	W18HA-A	W24HA-A	W24HA-B	W24HA-C
1	8000-313	Compressor	X			
1	8000-314	Compressor		X		
1	8000-315	Compressor			X	
1	8000-316	Compressor				X
NS	3000-1224	Molded Compressor Wire Harness (1-PH)	X	X		
NS	3000-1231	Molded Compressor Wire Harness (3-PH)			X	X
2	S900-291	Blower Assembly	X			
2	S900-326	Blower Assembly		X	X	
2	S900-327	Blower Assembly				X
3	8200-001	Fan Motor Mount	X	X	X	X
4	5151-033	Fan Blade	X	X	X	
4	5151-046	Fan Blade				X
5	8103-016	Outdoor Fan Motor	X	X	X	
5	8103-020	Outdoor Fan Motor				X
6	917-0309BX	Outdoor Coil (Includes Distributor)	X			
6	917-0310BX ①	Outdoor Coil – Coated (Includes Distributor)	O			
6	917-0313BX	Outdoor Coil (Includes Distributor)		X	X	X
6	917-0314BX ①	Outdoor Coil – Coated (Includes Distributor)		O	O	O
7	5625-145	Cooling Distributor Assembly	X			
7	5625-151	Cooling Distributor Assembly		X	X	X
8	917-0307BX	Indoor Coil (Includes Cooling Distributor)	X			
8	917-0308BX ①	Indoor Coil – Coated (Includes Cooling Distributor)	O			
8	917-0311BX	Indoor Coil (Includes Cooling Distributor)		X	X	X
8	917-0312BX ①	Indoor Coil – Coated (Includes Cooling Distributor)		O	O	O
9	7004-011	Air Filter 16" x 25" x 1" Disposable	X	X	X	X
9	7003-032 ①	Air Filter 16" x 25" x 1" Washable	O	O	O	O
9	7004-025 ①	Air Filter 16" x 25" x 2" Pleated Disposable	O	O	O	O
10	1171-022	1/4 Turn Fastener	X	X	X	X
11	1171-024	1/4 Turn Retainer	X	X	X	X
12	1171-023	1/4 Turn Receptacle	X	X	X	X
13	5650-038	Reversing Valve w/24V Solenoid Coil	X	X	X	X
14	5650-046	Reversing Valve 24V Solenoid	X	X	X	X
15	5650-044	Molded Plug 53" Lead	X	X	X	X
16	5201-019	Filter Drier, Bi-Directional, 3/8" Connections	X	X	X	X
17	8620-224	Defrost Sensor Kit	X	X	X	X
18	5651-218	Heating Expansion Valve	X	X	X	X
19	8406-142	High Pressure Switch (650#) Screw On	X	X	X	X
20	5625-016	Heating Distributor	X			
20	5625-014	Heating Distributor		X	X	X
NS	8406-135	Low Pressure Switch (14#) Screw On	X	X	X	X
NS	6031-009	Coremax Valve Core (Service Port)	2	2	2	2
NS	8406-112 ①	Low Ambient Fan Cycling Control (350#/225#)	O	O	O	O
NS	8408-028 ①	Outdoor Thermostat	O	O	O	O
NS	1171-028	Filter Door Clip	X	X	X	X
NS	1171-057	Filter Door Screw	X	X	X	X
NS	1171-027	Filter Door Screw Retainer	X	X	X	X

NS – Not Shown

① – Optional Component

X – Standard

O – Add-On Option

# FUNCTIONAL COMPONENTS - DEHUMIDIFICATION UNITS

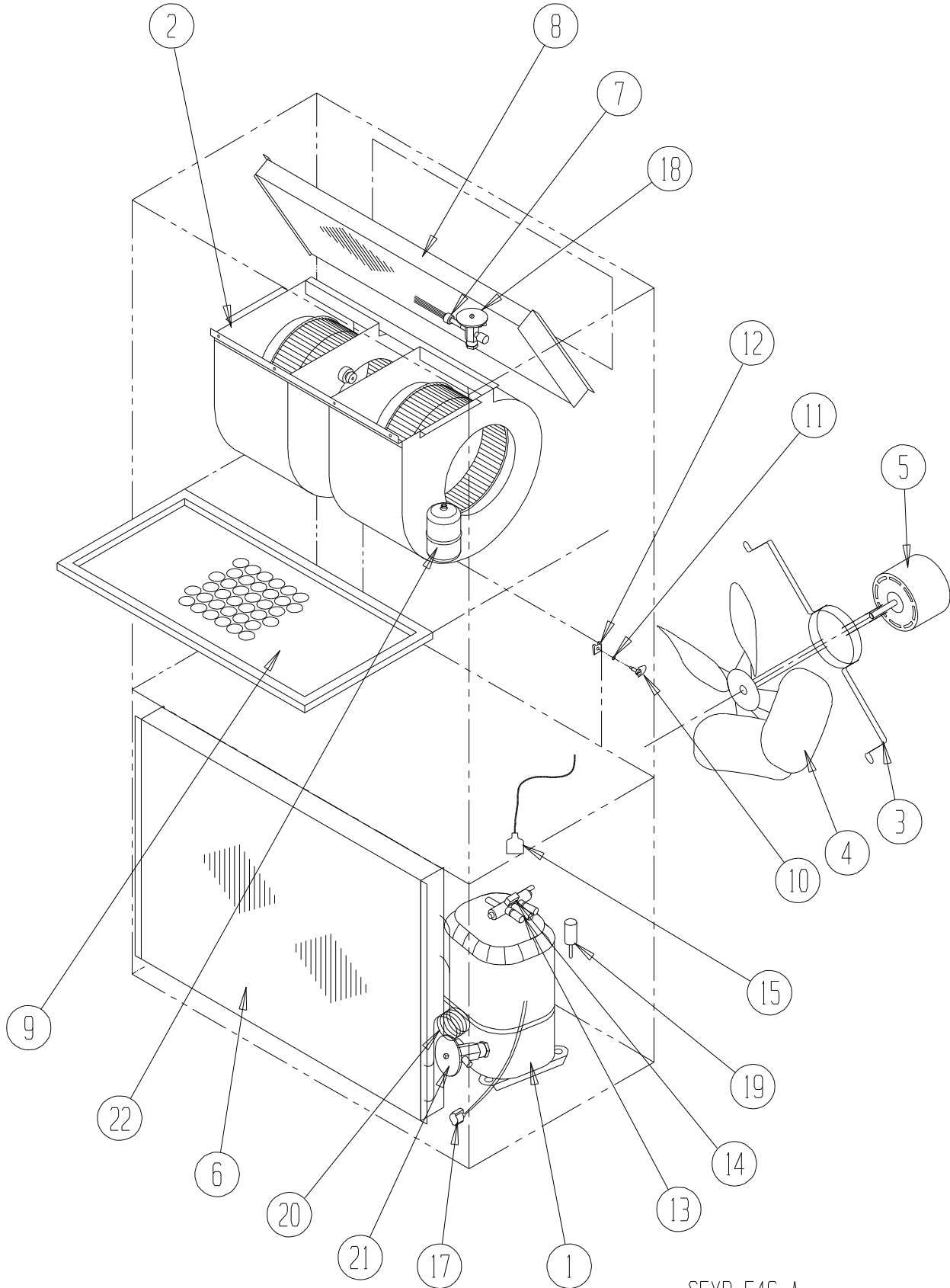

SEXP-546 A

# FUNCTIONAL COMPONENTS – DEHUMIDIFICATION UNITS

Dwg No.	Part Number	Description	W24HADA	W24HADB	W24HADC
1	8000-314	Compressor	X		
1	8000-315	Compressor		X	
1	8000-316	Compressor			X
NS	3000-1224	Molded Compressor Wire Harness (1-PH)	X		
NS	3000-1231	Molded Compressor Wire Harness (3-PH)		X	X
2	S900-231	Blower Assembly	X	X	
2	S900-232	Blower Assembly			X
3	8200-001	Fan Motor Mount	X	X	X
4	5151-033	Fan Blade	X	X	
4	5151-046	Fan Blade			X
5	8103-016	Outdoor Fan Motor	X	X	
5	8103-020	Outdoor Fan Motor			X
6	917-0313BX	Outdoor Coil (Includes Distributor)	X	X	X
6	917-0314BX ①	Outdoor Coil – Coated (Includes Distributor)	O	O	O
7	5625-128	Cooling Distributor	X	X	X
8	917-0282BX	Indoor Coil (Includes Cooling Distributor)	X	X	X
8	917-0317BX ①	Indoor Coil – Coated (Includes Cooling Distributor)	O	O	O
9	7004-011	Air Filter 16" x 25" x 1" Disposable	X	X	X
9	7003-032 ①	Air Filter 16" x 25" x 1" Washable	O	O	O
9	7004-025 ①	Air Filter 16" x 25" x 2" Pleated Disposable	O	O	O
10	1171-022	1/4 Turn Fastener	X	X	X
11	1171-024	1/4 Turn Retainer	X	X	X
12	1171-023	1/4 Turn Receptacle	X	X	X
13	5650-038	Reversing Valve w/24V Solenoid Coil	X	X	X
14	5650-046	Reversing Valve 24V Solenoid	X	X	X
15	5650-044	Molded Plug 53" Lead	X	X	X
16	5201-019	Filter Drier, Bi-Directional, 3/8" Connections	X	X	X
17	8620-224	Defrost Sensor Kit	X	X	X
18	5651-200	Cooling Expansion Valve	X	X	X
19	8406-142	High Pressure Switch (650#) Screw On	X	X	X
20	5625-014	Heating Distributor	X	X	X
21	5651-218	Heating Expansion Valve	X	X	X
NS	8406-135	Low Pressure Switch (14#) Screw On	X	X	X
NS	6031-009	Coremax Valve Core (Service Port)	2	2	2
NS	5650-051	Dehumidification Mode Valve	X	X	X
NS	5651-219	Dehumidification Check Valves	2	2	2
NS	8406-112 ①	Low Ambient Fan Cycling Control (350#/225#)	O	O	O
NS	8408-028 ①	Outdoor Thermostat	O	O	O
NS	1171-028	Filter Door Clip	X	X	X
NS	1171-057	Filter Door Screw	X	X	X
NS	1171-027	Filter Door Screw Retainer	X	X	X

NS – Not Shown  
 ① – Optional Component

X – Standard  
 O – Add-On Option





## CONTROL PANEL – 230 VOLT 1 PHASE UNITS

Dwg No.	Part Number	Description	W18HA-A	W24HA-A	W24HADADA
1	117X137	Control Panel Top - RH (Sheet Metal Only)	X	X	X
2	117X374	Control Panel - RH (Sheet Metal Only)	X	X	X
3	117X375	Low Voltage Box - RH (Sheet Metal Only)	X	X	X
4	117X385	Low Voltage Partition - RH (Sheet Metal Only)	X	X	X
NS	3000-1494	Low Voltage Wire Harness (behind LVTS)	X	X	X
NS	S910-2002	Complete Low Voltage Box Assembly (Sheet Metal, LVTS & Wire Harness)	X	X	X
5	141-188	Plug Support Bracket (Sheet Metal)	X	X	X
6	135-122	Wire Shield (Sheet Metal)	X	X	X
7	8401-033	Contactora 2-Pole	X	X	X
8	8407-035	Transformer 208/240-24, 50VA	X	X	X
9	8201-130	Relay, SPDT	X	X	X
10	8620-223	Defrost Board Replacement Kit	X	X	X
11	8607-044	Terminal Strip	X	X	X
12	8607-041	Park Terminal	X	X	X
13	8611-006	Ground Lug	X	X	X
25	8611-140-1400	14" Cable Duct	X	X	X
26	8611-140-0500	5" Cable Duct	X	X	X
27	8552-047	Capacitor 30+5/370 V, 2-1/2" Round	X		
27	8552-050	Capacitor 40+5/370 V, 2-1/2" Round		X	X
28	8550-008	Capacitor Strap, 2-1/2" Round	X	X	X
31	8201-113	Dehumidification Logic Control Board			X
NS	3003-038	Main Control Panel Wire Harness	X	X	
NS	3003-041	Main Control Panel Wire Harness			X
NS	8201-086 ①	LAC and/or ODT Relay	0	0	0
NS	8408-028 ①	Outdoor Thermostat	0	0	0

NS – Not Shown  
 ① – Optional

X – Standard  
 O – Add-On Option



## CONTROL PANEL – 230 VOLT 3 PHASE UNITS

Dwg No.	Part Number	Description	W24HA-B	W24HADB
1	117X137	Control Panel Top - RH (Sheet Metal Only)	X	X
2	117X374	Control Panel - RH (Sheet Metal Only)	X	X
3	117X375	Low Voltage Box - RH (Sheet Metal Only)	X	X
4	117X385	Low Voltage Partition - RH (Sheet Metal Only)	X	X
NS	3000-1494	Low Voltage Wire Harness (behind LVTS)	X	X
NS	S910-2002	Complete Low Voltage Box Assembly (Sheet Metal, LVTS & Wire Harness)	X	X
5	141-188	Plug Support Bracket (Sheet Metal)	X	X
6	135-122	Wire Shield (Sheet Metal)	X	X
7	8401-035	Contactors 3-Pole	X	X
8	8407-035	Transformer 208/240-24, 50VA	X	X
9	8201-130	Relay, SPDT	X	X
10	8620-223	Defrost Board Replacement Kit	X	X
11	8607-044	Terminal Strip	X	X
12	8607-041	Park Terminal	X	X
13	8611-006	Ground Lug	X	X
25	8611-140-1400	14" Cable Duct	X	X
26	8611-140-0500	5" Cable Duct	X	X
27	8552-002	Capacitor 5/370 V, 1-1/4" Oval	X	X
28	8550-003	Capacitor Strap, 1-1/4" Oval	X	X
29	8201-126	3 Phase Line Monitor	X	X
31	8201-113	Dehumidification Logic Control Board		X
NS	3003-039	Main Control Panel Wire Harness	X	
NS	3003-042	Main Control Panel Wire Harness		X
NS	8201-086 ①	LAC and/or ODT Accessory Relay	0	0
NS	8408-028 ①	Outdoor Thermostat	0	0

NS – Not Shown

① – Optional

X – Standard

0 – Add-On Option



## CONTROL PANEL – 460 VOLT 3 PHASE UNITS

Dwg No.	Part Number	Description	W24HA-C	W24HADC
1	117X137	Control Panel Top - RH (Sheet Metal Only)	X	X
2	117X374	Control Panel - RH (Sheet Metal Only)	X	X
3	117X375	Low Voltage Box - RH (Sheet Metal Only)	X	X
4	117X385	Low Voltage Partition - RH (Sheet Metal Only)	X	X
NS	3000-1494	Low Voltage Wire Harness (behind LVTS)	X	X
NS	S910-2002	Complete Low Voltage Box Assembly (Sheet Metal, LVTS & Wire Harness)	X	X
5	141-188	Plug Support Bracket (Sheet Metal)	X	X
6	135-122	Wire Shield (Sheet Metal)	X	X
7	8401-035	Contactors 3-Pole	X	X
8	8407-042	Transformer 480-24, 50VA	X	X
9	8201-132	Relay, SPDT, 3 FLA@480V	X	X
10	8620-223	Defrost Board Replacement Kit	X	X
11	8607-044	Terminal Strip	X	X
12	8607-041	Park Terminal	X	X
13	8611-006	Ground Lug	X	X
25	8611-140-1400	14" Cable Duct	X	X
26	8611-140-0500	5" Cable Duct	X	X
27	8552-002	Capacitor 5/370 V, 1-1/4" Oval	X	X
28	8550-003	Capacitor Strap, 1-1/4" Oval	X	X
29	8201-126	3 Phase Line Monitor	X	X
31	8201-113	Dehumidification Logic Control Board		X
NS	3003-040	Main Control Panel Wire Harness	X	
NS	3003-043	Main Control Panel Wire Harness		X
NS	8201-086 ①	LAC and/or ODT Accessory Relay	O	O
NS	8408-028 ①	Outdoor Thermostat	O	O

NS – Not Shown

① – Optional

X – Standard

O – Add-On Option

# BLOWER ASSEMBLY

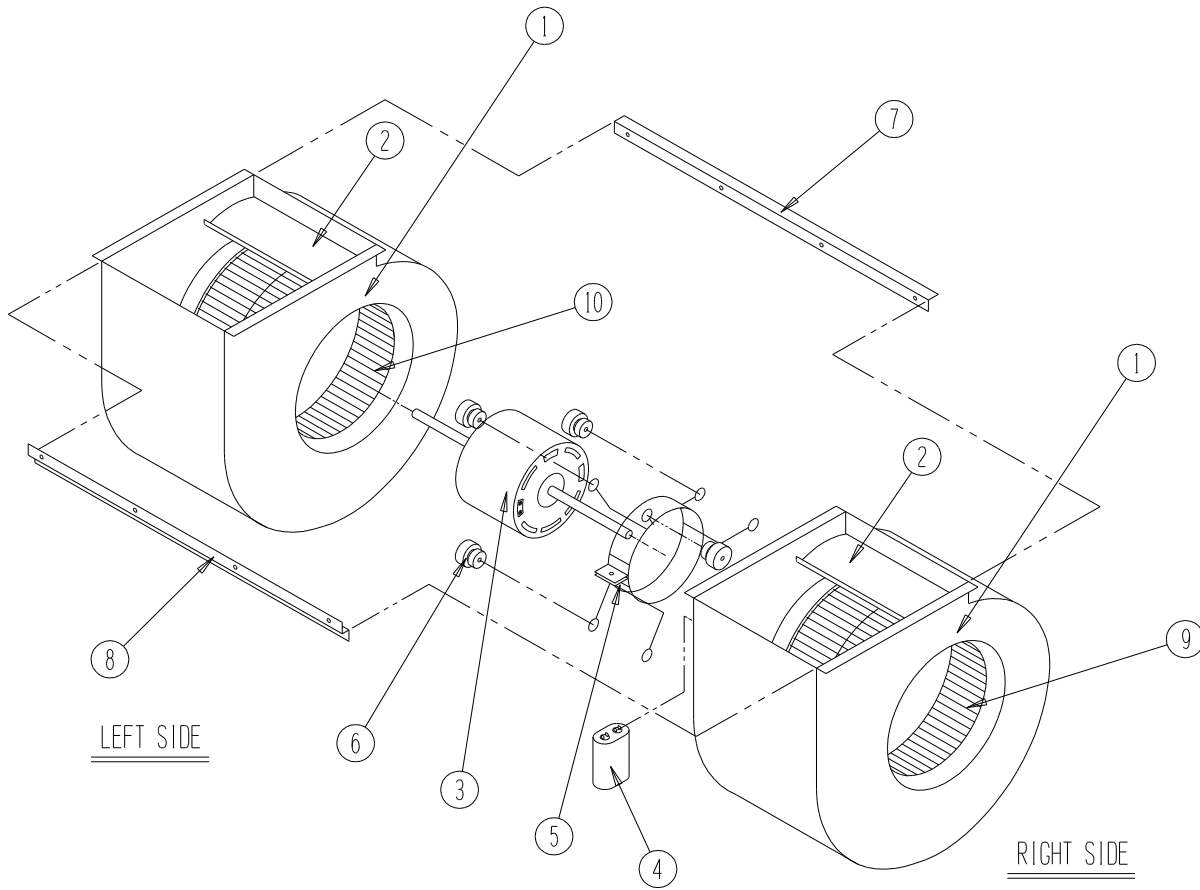

SEXP-346

Dwg No.	Part Number	Description	S900-326	S900-327	S900-291
1	151-115	Housing	2	2	2
2	144-183	Cutoff	X	X	X
3	8102-016	Blower Motor (230/208)	X		
3	8102-017	Blower Motor (460)		X	
3	8102-014	Blower Motor (230/208)			X
4	8552-002	Capacitor			X
4	8552-004	Capacitor	X	X	
5	8200-031	Motor Mount	X	X	X
6	5451-011	Grommets	6	6	6
7	105-1061	Back Brace	X	X	X
8	103-435	Front Brace	X	X	X
9	5152-092	Wheel 9-6 CW	X	X	X
10	5152-093	Wheel 9-6 CCW	X	X	X