REPLACEMENT PARTS MANUAL

Wall Mount Heat Pump

Models:

W42HF-A	W48HF-A	W60HF-A
W42HF-B	W48HF-B	W60HF-B
W42HF-C	W48HF-C	W60HF-C
W42HFDA	W48HFDA	W60HFDA
W42HFDB	W48HFDB	W60HFDB
W42HFDC	W48HFDC	W60HFDC

Contents

Description	Page	Description	Page
Heat Pump Wall Mount Model Nomenclature	2	Control Panel – Standard & Dehum.	
External Parts – Standard & Dehum.		♦ Layout View	16
♦ Exploded View	4	♦ Usage List	17
♦ Usage List	5	Blower Assembly	
♦ Usage List	6	♦ Exploded View	18
External Parts – Recessed Cabinet		♦ Usage List	18
♦ Exploded View	8		
♦ Usage List	9		
Internal Parts – Standard & Dehum.			
♦ Exploded View	10		
♦ Usage List	11		
Functional Components – Standard & Dehum.			
♦ Exploded View	12		
♦ Usage List	13		
♦ Usage List	14		
EEV Controller Assembly			
♦ Exploded View	15		
♦ Usage List	15		

General Notes

- Revised and/or additional pages may be issued from time to time.
- A complete and current manual consists of pages shown in the following contents section.

Important

- Contact the installing and/or local Bard distributor for all parts requirements. Make sure to have the complete model and serial number available from the unit rating plates.



Bard Manufacturing Company, Inc.
Bryan, Ohio 43506
www.bardhvac.com

Manual: 2110-1586B
Supersedes: 2110-1586A
Date: 9-23-25

HEAT PUMP WALL MOUNT MODEL NOMENCLATURE

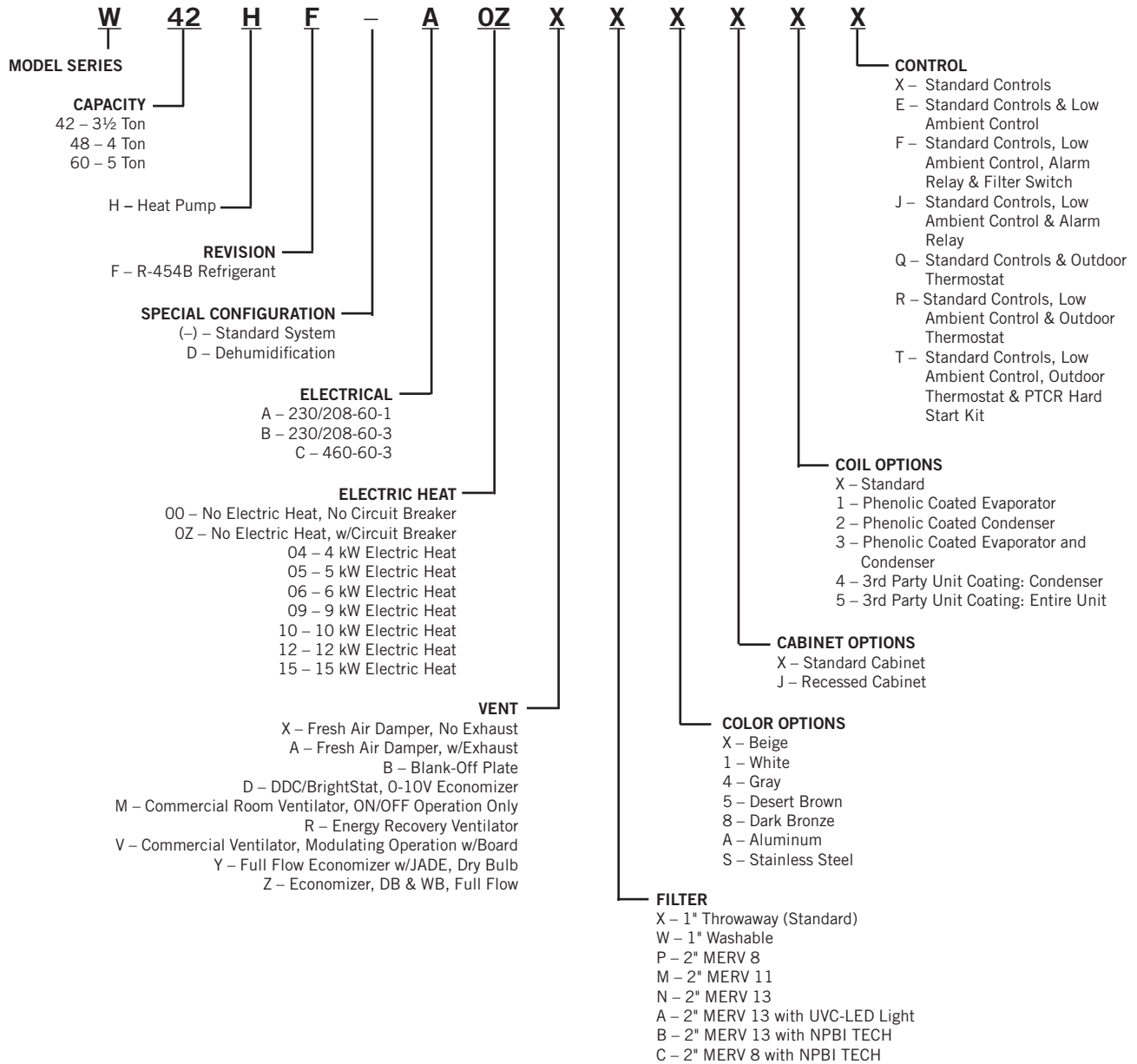

This page intentionally left blank

EXTERNAL PARTS – STANDARD & DEHUMIDIFICATION

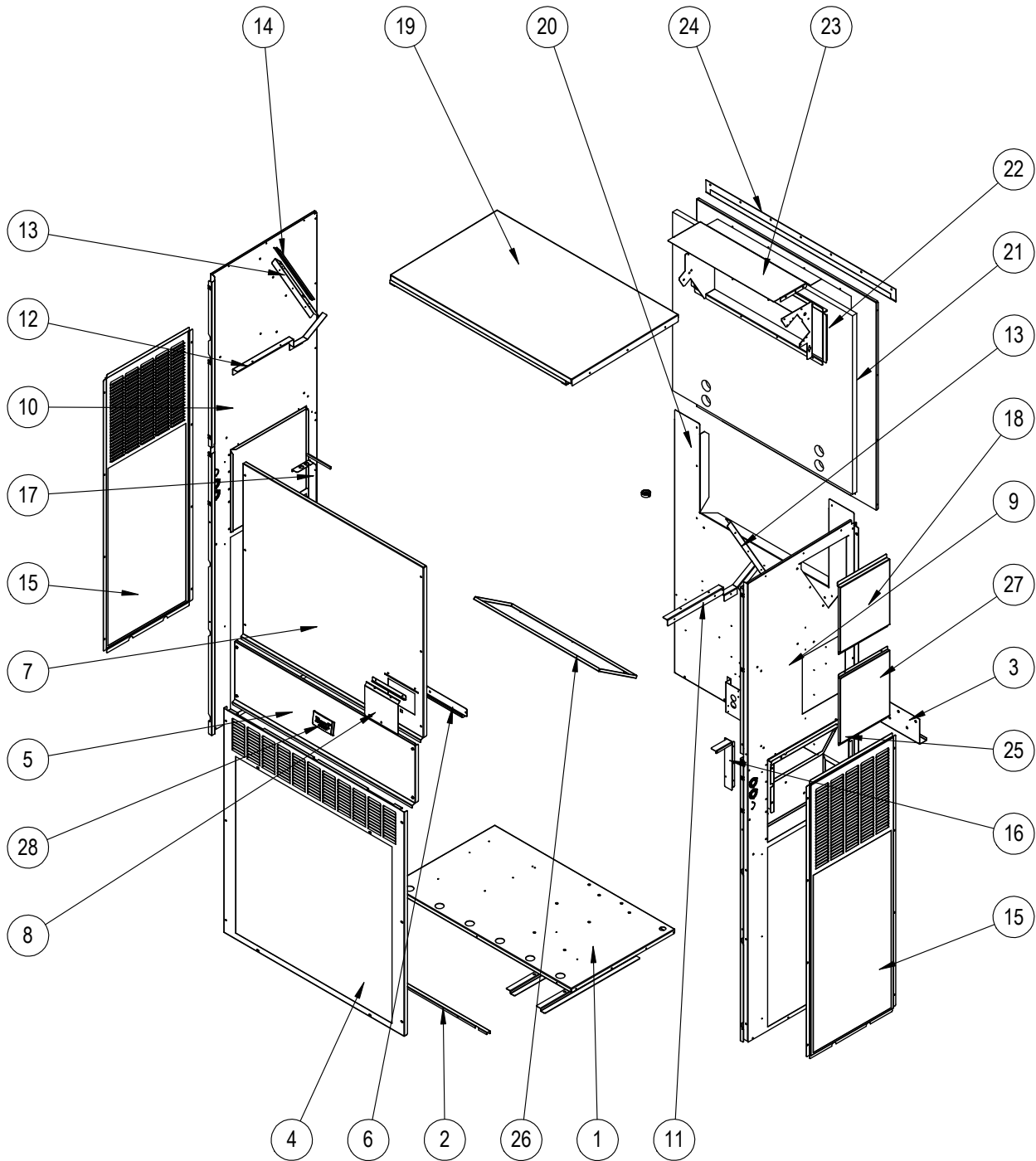

SEXP-1099

This drawing to be used for reference for pages 5 and 6

EXTERNAL PARTS – STANDARD & DEHUMIDIFICATION

Dwg No.	Part Number	Description	W42HF-A, B, C	W42HFDA, B, C	W48HF-A, B, C	W48HFDA, B, C	W60HF-A, B, C	W60HFDA, B, C
1	127-574BX	Unit Base	X	X	X	X	X	X
1	127-574BX ③	Unit Base	0	0	0	0	0	0
2	113-762BX	Front Base Bracket	X	X	X	X	X	X
2	113-797BX ③	Front Base Bracket	0	0	0	0	0	0
3	113-140BX	Bottom Mounting Bracket	X	X	X	X	X	X
4	119-125-*BX ①	Front Grille	X	X	X	X		
4	119-135BX ②	Front Grille	0	0	0	0		
4	119-148BX ③	Front Grille	0	0	0	0		
4	119-127-*BX ①	Front Grille					X	X
4	119-137BX ②	Front Grille					0	0
4	119-149BX ③	Front Grille					0	0
5	533-301-*BX ①	Control Panel Cover (Outer)	X	X	X	X	X	X
5	533-309BX ②	Control Panel Cover (Outer)	0	0	0	0	0	0
5	533-310BX ③	Control Panel Cover (Outer)	0	0	0	0	0	0
6	165-608-*BX ①	Rain Channel	X	X	X	X	X	X
6	165-609BX ②	Rain Channel	0	0	0	0	0	0
6	165-610BX ③	Rain Channel	0	0	0	0	0	0
For CABINET OPTIONS character X only (refer to page 2)								
7	515-323-*BX ①	Upper Front	X	X	X	X		
7	515-328BX ②	Upper Front	0	0	0	0		
7	515-330BX ③	Upper Front	0	0	0	0		
7	515-324-*BX ①	Upper Front					X	X
7	515-329BX ②	Upper Front					0	0
7	515-331BX ③	Upper Front					0	0
8	153-717-*BX ①	Disconnect Access Door	X	X	X	X	X	X
8	153-723BX ②	Disconnect Access Door	0	0	0	0	0	0
8	153-724BX ③	Disconnect Access Door	0	0	0	0	0	0
For CABINET OPTIONS character X only (refer to page 2)								
9	501-1197-*BX ①	Right Side	X	X	X	X		
9	501-1198BX ②	Right Side	0	0	0	0		
9	501-1199BX ③	Right Side	0	0	0	0		
9	501-1191-*BX ①	Right Side					X	X
9	501-1192BX ②	Right Side					0	0
9	501-1193BX ③	Right Side					0	0
For CABINET OPTIONS character X only (refer to page 2)								
10	501-1194-*BX ①	Left Side	X	X	X	X		
10	501-1195BX ②	Left Side	0	0	0	0		
10	501-1196BX ③	Left Side	0	0	0	0		
10	501-1188-*BX ①	Left Side					X	X
10	501-1189BX ②	Left Side					0	0
10	501-1190BX ③	Left Side					0	0
11	105X1454BX	Right Support Angle	X	X	X	X	X	X
12	105Y1454BX	Left Support Angle	X	X	X	X	X	X
13	105-1457BX	Coil Support	2	2	2	2		
13	105-1455BX	Coil Support					2	2
14	147-055BX	Coil Support Offset	X	X	X	X		
14	147-054BX	Coil Support Offset					X	X

Continued on page 6

① Exterior cabinet parts are manufactured with various paint color options. To ensure the proper paint color is received, include the complete model and serial number of the unit for which cabinet parts are being ordered.

X – Standard Component
O – Optional Component

② Exterior cabinet parts are manufactured from aluminum Code "A"
③ Exterior cabinet parts are manufactured from stainless steel Code "S"

EXTERNAL PARTS – STANDARD & DEHUMIDIFICATION

Dwg No.	Part Number	Description	W42HF-A, B, C	W42HFDA, B, C	W48HF-A, B, C	W48HFDA, B, C	W60HF-A, B, C	W60HFDA, B, C
<i>Continued from page 5</i>								
15	119-126-*BX ①	Side Grille	2	2	2	2		
15	119-142BX ②	Side Grille (Optional)	2	2	2	2		
15	119-136BX ③	Side Grille (Optional)	2	2	2	2		
15	119-128-*BX ①	Side Grille					2	2
15	119-143BX ②	Side Grille (Optional)					2	2
15	119-138BX ③	Side Grille (Optional)					2	2
16	105-1450BX	Right Control Panel Angle	X	X	X	X	X	X
17	105-1451BX	Left Control Panel Angle	X	X	X	X	X	X
18	543-221-*BX ①	Heater Access Cover	X	X	X	X	X	X
18	543-228BX ②	Heater Access Cover	0	0	0	0	0	0
18	543-229BX ③	Heater Access Cover	0	0	0	0	0	0
For CABINET OPTIONS character X only (refer to page 2)								
19	507-382-*BX ①	Top	X	X	X	X	X	X
19	507-391BX ②	Top	0	0	0	0	0	0
19	507-392BX ③	Top	0	0	0	0	0	0
20	109-412BX	Lower Back	X	X	X	X		
20	109-418BX	Lower Back	0	0	0	0		
20	109-422BX ③	Lower Back	0	0	0	0		
20	109-414BX	Lower Back					X	X
20	109-420BX	Lower Back					0	0
20	109-424BX ③	Lower Back					0	0
21	509-411BX	Upper Back	X	X	X	X		
21	509-417BX	Upper Back	0	0	0	0		
21	509-421BX ③	Upper Back	0	0	0	0		
21	509-413BX	Upper Back					X	X
21	509-419BX	Upper Back					0	0
21	509-423BX ③	Upper Back					0	0
22	111-299BX	Outlet Air Frame Assembly	X	X	X	X	X	X
23	535-129BX	Heat Shield	X	X	X	X	X	X
24	113-150-*BX ①	Top Rain Flashing	X	X	X	X	X	X
24	113-359BX ③	Top Rain Flashing	0	0	0	0	0	0
25	539-406BX	Fresh Air Damper Assembly	X	X	X	X	X	X
25	543-222BX	Intake Blank-Off Plate	0	0	0	0	0	0
26	543-220BX	Exhaust Blank-Off Plate	X	X	X	X	X	X
27	543-248-*BX ①	Access Cover	X	X	X	X	X	X
27	543-250BX ②	Access Cover	0	0	0	0	0	0
27	543-251BX ③	Access Cover	0	0	0	0	0	0
28	5252-033BX	Bard Nameplate	X	X	X	X	X	X

NS = Not Shown

X – Standard Component
O – Optional Component

- ① Exterior cabinet parts are manufactured with various paint color options. To ensure the proper paint color is received, include the complete model and serial number of the unit for which cabinet parts are being ordered.
- ② Exterior cabinet parts are manufactured from aluminum Code "A"
NOTE: #24 - Top rain flashing not available in aluminum; order 113-150-4 (Buckeye Gray).
- ③ Exterior cabinet parts are manufactured from stainless steel Code "S"

Refer to drawing on page 4

This page intentionally left blank

EXTERNAL PARTS - RECESSED CABINET

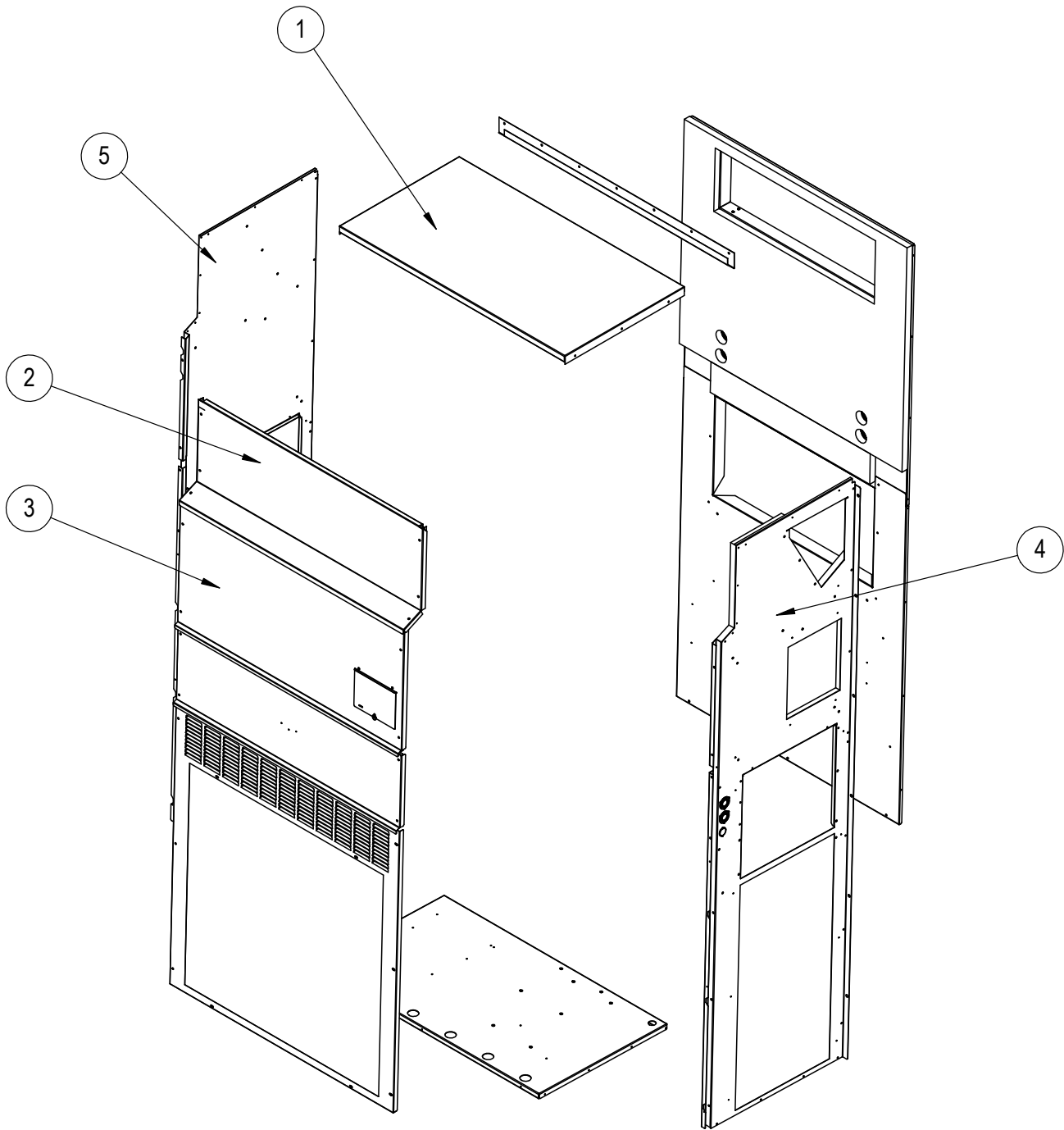

SEXP-1088

EXTERNAL PARTS – RECESSED CABINET

For CABINET OPTIONS character J only (refer to page 2)

Drawing No.	Part Number	Description	W42HF-A, B, C	W48HF-A, B, C	W60HF-A, B, C
1	507-413-*BX ①	Top	X	X	X
2	515-354-*BX ①	Upper Front	X	X	
2	515-356-*BX ①	Upper Front			X
3	515-355-*BX ①	Center Front	X	X	
3	515-357-*BX ①	Center Front			X
4	501-1203-*BX ①	Right Side Assembly	X	X	
4	501-1201-*BX ①	Right Side Assembly			X
5	501-1202-*BX ①	Left Side Assembly	X	X	
5	501-1200-*BX ①	Left Side Assembly			X

① Exterior cabinet parts are manufactured with various paint color options. To ensure the proper paint color is received, include the complete model and serial number of the unit for which cabinet parts are being ordered.

NOTE: The replacement cabinet parts listed above are specific to the recessed unit W42/48/60HF wall mount air conditioner models. All other replacement cabinet external parts for these models are referenced on pages 4, 5 and 6.

INTERNAL PARTS – STANDARD & DEHUMIDIFICATION

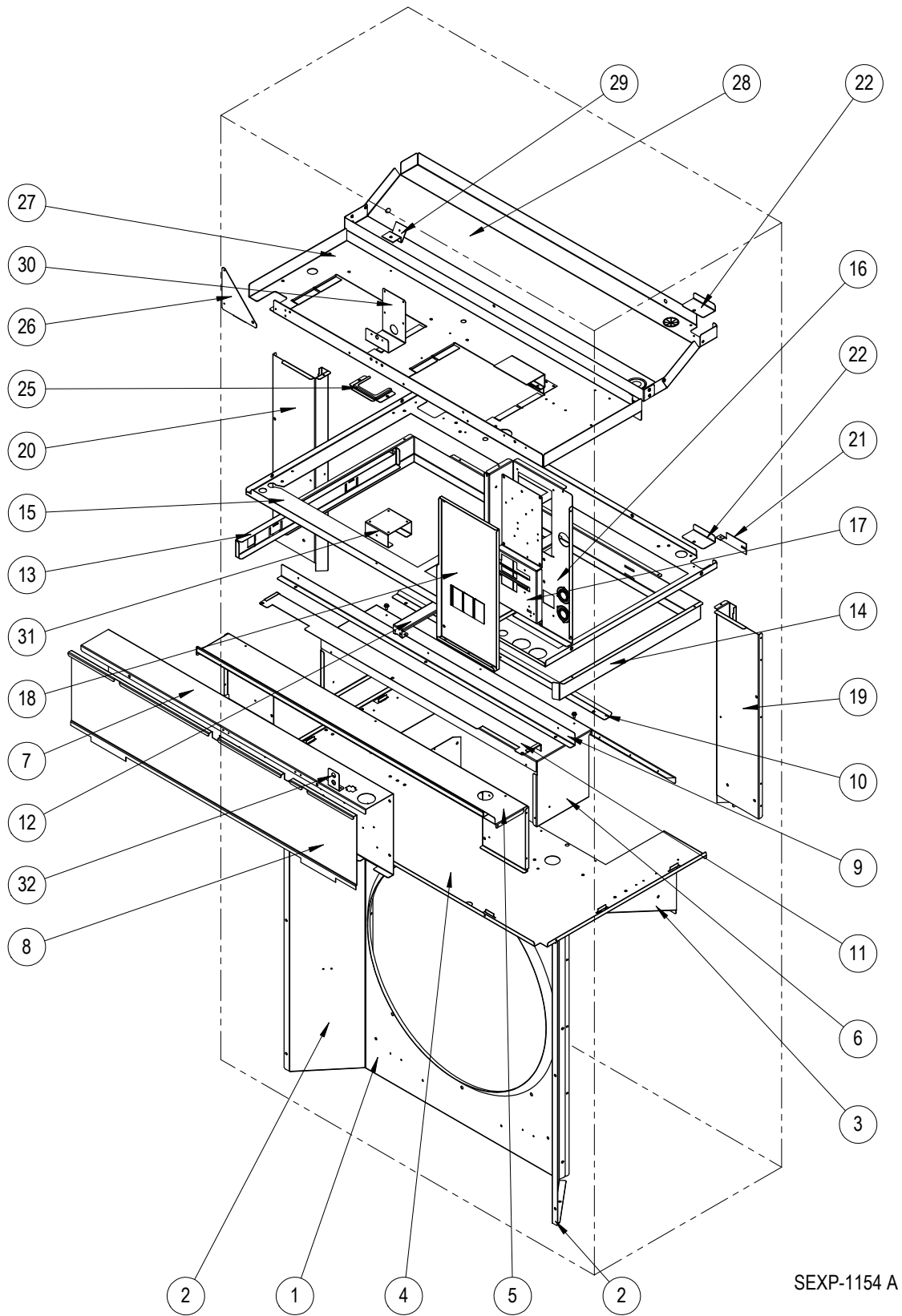

SEXP-1154 A

INTERNAL PARTS – STANDARD & DEHUMIDIFICATION

Dwg No.	Part Number	Description	W42HF-A, B	W42HF-C	W42HFDA, B	W42HFDC	W48HF-A, B	W48HF-C	W48HFDA, B	W48HFDC	W60HF-A, B	W60HF-C	W60HFDA, B	W60HFDC
1	125-089BX	Fan Shroud	X	X	X	X	X	X	X	X				
1	125-091BX	Fan Shroud									X	X	X	X
1	125-093BX ①	Fan Shroud	0	0	0	0	0	0	0	0	0	0	0	0
1	125-095BX ①	Fan Shroud									0	0	0	0
2	125-090BX	Fan Shroud Side Access Cover	2	2	2	2	2	2	2	2				
2	125-094BX ①	Fan Shroud Side Access Cover	2	2	2	2	2	2	2	2				
2	125-092BX	Fan Shroud Side Access Cover									2	2	2	2
2	125-096BX ①	Fan Shroud Side Access Cover									2	2	2	2
3	121-586BX	Condenser Partition Insert	X	X	X	X	X	X	X	X	X	X	X	X
4	121-585BX	Condenser Partition	X	X	X	X	X	X	X	X	X	X	X	X
4	121-599BX ①	Condenser Partition	0	0	0	0	0	0	0	0	0	0	0	0
5	521-630BX	Front Exhaust Partition	X	X	X	X	X	X	X	X	X	X	X	X
6	521-587BX	Exhaust Partition	X	X	X	X	X	X	X	X	X	X	X	X
7	Control Panel Assy.	See Control Panel on pages 16 & 17	X	X	X	X	X	X	X	X	X	X	X	X
8	133-370BX	Control Panel Cover (Inner)	X	X	X	X	X	X	X	X	X	X	X	X
9	105-1453BX	Front Vent Guide Rail	X	X	X	X	X	X	X	X	X	X	X	X
10	105-1452BX	Vent Guide Rail	X	X	X	X	X	X	X	X	X	X	X	X
11	135-409BX	Field Wire Shield	X	X	X	X	X	X	X	X	X	X	X	X
12	131-168BX	Filter Support Bracket	2	2	2	2	2	2	2	2	2	2	2	2
13	131-170BX	Filter Slide	X	X	X	X	X	X	X	X	X	X	X	X
14	131-169BX	Filter Rack Frame	X	X	X	X	X	X	X	X	X	X	X	X
15	121-583BX	Filter Partition	X	X	X	X	X	X	X	X	X	X	X	X
16	117-412BX	Upper Control Panel	X	X	X	X	X	X	X	X	X	X	X	X
17	127-575BX	Circuit Breaker Base	X		X		X		X		X		X	
17	127-585BX	Circuit Breaker Base - 460V		X		X		X		X		X		X
18	133-303BX	Upper Control Panel Cover	X		X		X		X		X		X	
18	133-304BX	Upper Control Panel Cover - 460V		X		X		X		X		X		X
19	135X393BX	Right Copper Chase	X	X	X	X	X	X	X	X	X	X	X	X
20	135Y393BX	Left Copper Chase	X	X	X	X	X	X	X	X	X	X	X	X
21	113-796BX	Copper Retainer			2	2			2	2			2	2
22	137-920BX	Copper Fill Plate	2	2			2	2			2	2		
25	113-765BX	Grommet Retainer Bracket	X	X	X	X	X	X	X	X	X	X	X	X
26	141-492BX	Blower Partition Support	X	X	X	X	X	X	X	X	X	X	X	X
27	121-582BX	Blower Partition	X	X	X	X	X	X	X	X	X	X	X	X
28	523-161BX	Drain Pan	X	X	X	X	X	X	X	X	X	X	X	X
28	523-162BX ①②	Drain Pan	0	0	0	0	0	0	0	0	0	0	0	0
29	113-768BX	EEV mounting Bracket			X	X			X	X			X	X
30	113-787BX	Airflow Switch Bracket	0	0	0	0	0	0	0	0	0	0	0	0
31	113-788BX	Filter Switch Bracket	0	0	0	0	0	0	0	0	0	0	0	0
32	113-789BX	Filter Switch Light Bracket	0	0	0	0	0	0	0	0	0	0	0	0
NS	113-809BX	Heating Expansion Valve Bracket	X	X			X	X			X	X		
NS	113-381BX	TXV Bulb Bracket	X	X			X	X			X	X		

① Exterior cabinet parts are manufactured from stainless steel Code "S"

② For aluminum units, order 523-162 stainless steel drain pan.

X – Standard Component

0 – Optional Component

FUNCTIONAL COMPONENTS – STANDARD & DEHUMIDIFICATION

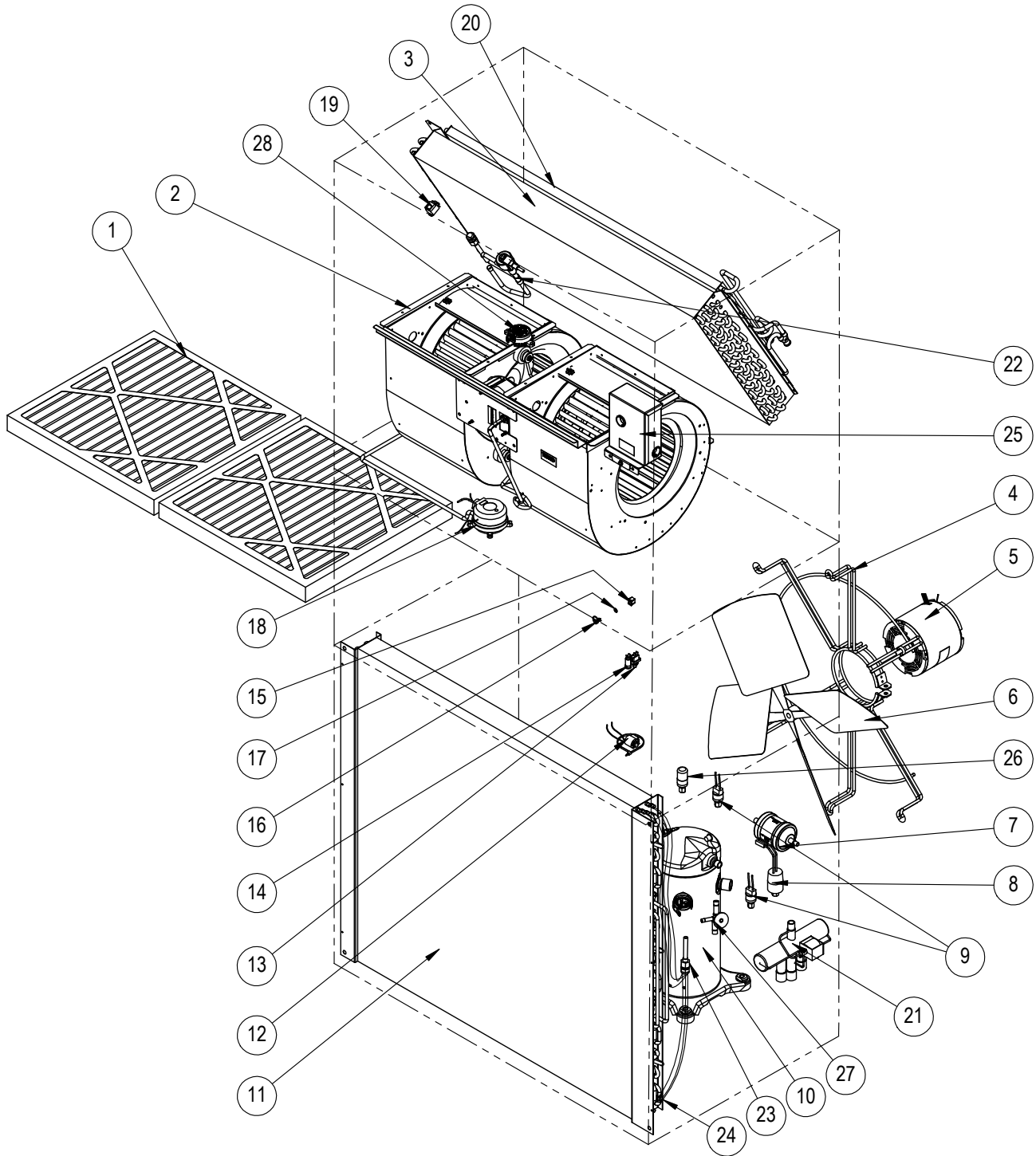

SEXP-1156

This drawing to be used for reference for pages 13 and 14

FUNCTIONAL COMPONENTS – STANDARD & DEHUMIDIFICATION

Dwg No.	Part Number	Description	W42HF-A	W42HF-B	W42HF-C	W42HFDA	W42HFDB	W42HFDC	W48HF-A	W48HF-B	W48HF-C	W48HFDA	W48HFDB	W48HFDC
1	7004-012	Air Filter 1" Throw-Away (20 x 20 x 1)	2	2	2	2	2	2	2	2	2	2	2	2
1	7003-085 ②	Air Filter 1" Washable (20 x 20 x 1)	2	2	2	2	2	2	2	2	2	2	2	2
1	7004-052 ②	Air Filter 2" Merv 8 (20 x 20 x 2)	2	2	2	2	2	2	2	2	2	2	2	2
1	7004-060 ②	Air Filter 2" Merv 11 (20 x 20 x 2)	2	2	2	2	2	2	2	2	2	2	2	2
1	7004-063 ②	Air Filter 2" Merv 13 (20 x 20 x 2)	2	2	2	2	2	2	2	2	2	2	2	2
2	900-366-0185BX	Blower Assembly	X	X		X	X							
2	900-367-0176BX	Blower Assembly - 460V			X			X						
2	900-368-0177BX	Blower Assembly							X	X		X	X	
2	900-369-0178BX	Blower Assembly - 460V									X			X
3	917-0559BX	Indoor Coil w/Distributor Assy.	X	X	X									
3	917-0561BX	Indoor Coil - Coated w/Distributor Assy.	O	O	O									
3	917-0562BX	Indoor Coil w/Distributor Assy.							X	X	X			
3	917-0564BX	Indoor Coil - Coated w/Distributor Assy.							O	O	O			
3	917-0405BX	Indoor Coil w/Distributor Assy.				X	X	X						
3	917-0406BX	Indoor Coil - Coated w/Distributor Assy.				O	O	O						
3	917-0409BX	Indoor Coil w/Distributor Assy.										X	X	X
3	917-0410BX	Indoor Coil - Coated w/Distributor Assy.										O	O	O
4	8200-004BX	Fan Motor Mount	X	X	X	X	X	X	X	X	X	X	X	X
4	8200-051BX ①	Fan Motor Mount - Stainless Steel	O	O	O	O	O	O	O	O	O	O	O	O
5	8105-078BX	Condenser Motor	X	X		X	X		X	X		X	X	
5	8105-071BX	Condenser Motor - 460V			X			X			X			X
6	5151-060BX	Fan Blade	X	X	X	X	X	X	X	X	X	X	X	X
6	5151C060BX ①	Fan Blade - Coated	O	O	O	O	O	O	O	O	O	O	O	O
7	5201-020BX	Filter Drier	X	X	X	X	X	X	X	X	X	X	X	X
8	CMH-35	Low Ambient Control (LAC) Kit = #8, 12, 19	O	O	O	O	O	O	O	O	O	O	O	O
9	8406-167BX	High Pressure Switch	X	X	X	X	X	X	X	X	X	X	X	X
9	8406-168BX	Low Pressure Switch	X	X	X	X	X	X	X	X	X	X	X	X
10	8000-503BX	Compressor	X			X								
10	8000-504BX	Compressor		X			X							
10	8000-505BX	Compressor			X			X						
10	8000-506BX	Compressor							X			X		
10	8000-507BX	Compressor								X			X	
10	8000-508BX	Compressor									X			X
11	917-0413BX	Condenser Coil (Includes Distributor)	X	X	X	X	X	X						
11	917-0414BX	Condenser Coil - Coated (Includes Distributor)	O	O	O	O	O	O						
11	917-0415BX	Condenser Coil Assembly (Includes Distributor)							X	X	X	X	X	X
11	917-0416BX	Outdoor Coil - Coated (Includes Distributor)							O	O	O	O	O	O
12	8408-055BX	Outdoor Temperature Sensor	O	O	O	O	O	O	O	O	O	O	O	O
13	3000-1638BX	Dirty Filter Reset Switch	O	O	O	O	O	O	O	O	O	O	O	O
14	8611-094BX	Red Indicator Light - 24VAC	O	O	O	O	O	O	O	O	O	O	O	O
15	1171-023	1/4 Turn Receptacle	X	X	X	X	X	X	X	X	X	X	X	X
16	1171-022	1/4 Turn Fastener	X	X	X	X	X	X	X	X	X	X	X	X
17	1171-024	1/4 Turn Retainer	X	X	X	X	X	X	X	X	X	X	X	X
18	8301-057BX	Filter Pressure Switch	O	O	O	O	O	O	O	O	O	O	O	O
19	CMC-29	Freeze Protection Thermostat	O	O	O	O	O	O	O	O	O	O	O	O
20	5051-221BX	Reheat Coil				X	X	X				X	X	X
20	5054-221BX	Reheat Coil - Coated				O	O	O				O	O	O
21	5650-040BX	Reversing Valve	X	X	X	X	X	X	X	X	X	X	X	X
22	800-0512BX	Distributor Assembly - Indoor Coil	X	X	X									
22	800-0513BX	Distributor Assembly - Indoor Coil							X	X	X			
22	800-0461BX	Distributor Assembly - Indoor Coil				X	X	X						
22	800-0424BX	Distributor Assembly - Indoor Coil										X	X	X
22	5651-245BX ③	Electronic Expansion Valve				X	X	X				X	X	X
22	905-0737BX ③	Electronic Expansion Valve (EEV) Assembly				X	X	X				X	X	X
23	800-0424BX	Distributor Assembly - Outdoor Coil	X	X	X	X	X	X				X	X	X
23	800-0467BX	Distributor Assembly - Outdoor Coil							X	X	X	X	X	X
24	8620-225BX	Defrost Thermistor Sensor	X	X	X	X	X	X	X	X	X	X	X	X
25	910-2050-005BX	EEV Controller (see EEV Controller Assembly)				X	X	X				X	X	X
26	8406-158BX	Low Pressure Transducer - Blue				X	X	X				X	X	X
27	5651-262BX	Heating Expansion Valve	X	X	X									
27	5651-263BX	Heating Expansion Valve							X	X	X			
28	8301-110BX	RDS Sensor	X	X	X	X	X	X	X	X	X	X	X	X
NS	8401-036BX	RDS Relay	X	X	X	X	X	X	X	X	X	X	X	X
NS	CMC-33	Dirty Filter Switch Kit = Item #'s 13,14,18	O	O	O	O	O	O	O	O	O	O	O	O
NS	5650-051BX	Dehumidification Valve				X	X	X				X	X	X
NS	5650-042BX	Dehum/Rev. Valve Solenoid, Red Casing (Ranco)	X	X	X	X	X	X	X	X	X	X	X	X
NS	5650-046BX	Dehum/Rev. Valve Solenoid, Black Casing (San Hua)	X	X	X	X	X	X	X	X	X	X	X	X
NS	5651-219BX	Check Valve				2	2	2				2	2	2
NS	5451-024	Tubing Isolation Grommet	2	2	2	4	4	4	2	2	2	4	4	4
NS	6031-009	Coremax Valve Core	2	2	2	2	2	2	2	2	2	2	2	2
NS	1171-028	Control Panel Door Clip	4	4	4	4	4	4	4	4	4	4	4	4
NS	1171-057	Control Panel Door Screw	4	4	4	4	4	4	4	4	4	4	4	4
NS	1171-027	Control Panel Door Screw Retainer	4	4	4	4	4	4	4	4	4	4	4	4
NS	3000-1813BX	Reversing Valve Wiring Harness	X	X	X	X	X	X	X	X	X	X	X	X
NS	3000-1814BX	Dehum Valve Wiring Harness				X	X	X				X	X	X
NS	8620-343	UV-C Field Install Kit	O	O	O	O	O	O	O	O	O	O	O	O
NS	8620-370	AIR4 NBPI Field Install Kit	O	O	O	O	O	O	O	O	O	O	O	O

① – Used with stainless steel cabinet option
 ② – Optional on these models
 ③ – Not shipped with stator and harness. Refer to **EEV CONTROLLER ASSEMBLY** on page 18 for part numbers.

X – Standard Component
 O – Optional Component
 NS – Not Shown

FUNCTIONAL COMPONENTS – STANDARD & DEHUMIDIFICATION

Dwg No.	Part Number	Description	W60HF-A	W60HF-B	W60HF-C	W60HFDA	W60HFDB	W60HFDC
1	7004-012	Air Filter 1" Throw-Away (20 x 20 x 1)	2	2	2	2	2	2
1	7003-085 ②	Air Filter 1" Washable (20 x 20 x 1)	2	2	2	2	2	2
1	7004-052 ②	Air Filter 2" Merv 8 (20 x 20 x 2)	2	2	2	2	2	2
1	7004-060 ②	Air Filter 2" Merv 11 (20 x 20 x 2)	2	2	2	2	2	2
1	7004-063 ②	Air Filter 2" Merv 13 (20 x 20 x 2)	2	2	2	2	2	2
2	900-368-0179BX	Blower Assembly	X	X		X	X	
2	900-369-0180BX	Blower Assembly - 460V			X			X
3	917-0565BX	Indoor Coil w/Distributor Assy.	X	X	X			
3	917-0567BX	Indoor Coil - Coated w/Distributor Assy.	0	0	0			
3	917-0376BX	Indoor Coil w/Distributor Assy.				X	X	X
3	917-0377BX	Indoor Coil - Coated w/Distributor Assy.				0	0	0
4	8200-004BX	Fan Motor Mount	X	X	X	X	X	X
4	8200-051BX ①	Fan Motor Mount - Stainless Steel	0	0	0	0	0	0
5	8105-078BX	Condenser Motor	X	X		X	X	
5	8105-071BX	Condenser Motor - 460V			X			X
6	5151-060BX	Fan Blade	X	X	X	X	X	X
6	5151C060BX ①	Fan Blade - Coated	0	0	0	0	0	0
7	5201-020BX	Filter Drier	X	X	X	X	X	X
8	CMH-35	Low Ambient Control (LAC) Kit = #8, 12, 19	0	0	0	0	0	0
9	8406-167BX	High Pressure Switch	X	X	X	X	X	X
9	8406-168BX	Low Pressure Switch	X	X	X	X	X	X
10	8000-510BX	Compressor	X			X		
10	8000-511BX	Compressor		X			X	
10	8000-512BX	Compressor			X			X
11	917-0417BX	Condenser Coil Assembly (Includes Distributor)	X	X	X	X	X	X
11	917-0418BX	Outdoor Coil - Coated (Includes Distributor)	0	0	0	0	0	0
12	8408-055BX	Outdoor Temperature Sensor	0	0	0	0	0	0
13	3000-1638BX	Dirty Filter Reset Switch	0	0	0	0	0	0
14	8611-094BX	Red Indicator Light - 24VAC	0	0	0	0	0	0
15	1171-023	1/4 Turn Receptacle	X	X	X	X	X	X
16	1171-022	1/4 Turn Fastener	X	X	X	X	X	X
17	1171-024	1/4 Turn Retainer	X	X	X	X	X	X
18	8301-057BX	Filter Pressure Switch	0	0	0	0	0	0
19	CMC-29	Freeze Protection Thermostat	0	0	0	0	0	0
20	5051-221BX	Reheat Coil				X	X	X
20	5054-221BX	Reheat Coil - Coated				0	0	0
21	5650-040BX	Reversing Valve	X	X	X	X	X	X
22	800-0514BX	Distributor Assembly - Indoor Coil	X	X	X			
22	800-0455BX	Distributor Assembly - Indoor Coil				X	X	X
22	5651-248BX	Electronic Expansion Valve				X	X	X
22	905-0745BX	Electronic Expansion Valve (EEV) Assembly				X	X	X
23	800-0445BX	Distributor Assembly - Outdoor Coil	X	X	X	X	X	X
24	8620-225BX	Defrost Thermistor Sensor	X	X	X	X	X	X
25	910-2050-005BX	EEV Controller (see EEV Controller Assembly)				X	X	X
26	8406-158BX	Low Pressure Transducer - Blue				X	X	X
27	5651-263BX	Heating Expansion Valve	X	X	X			
28	8301-110BX	RDS Sensor	X	X	X	X	X	X
NS	8401-036BX	RDS Relay						
NS	CMC-33	Dirty Filter Switch Kit = Item #'s 13,14,18	0	0	0	0	0	0
NS	5650-051BX	Dehumidification Valve				X	X	X
NS	5650-042BX	Dehum/Rev. Valve Solenoid, Red Casing (Ranco)	X	X	X	X	X	X
NS	5650-046BX	Dehum/Rev. Valve Solenoid, Black Casing (San Hua)	X	X	X	X	X	X
NS	5651-219BX	Check Valve				2	2	2
NS	5451-024	Tubing Isolation Grommet	2	2	2	4	4	4
NS	6031-009	Coremax Valve Core	2	2	2	2	2	2
NS	1171-028	Control Panel Door Clip	4	4	4	4	4	4
NS	1171-057	Control Panel Door Screw	4	4	4	4	4	4
NS	1171-027	Control Panel Door Screw Retainer	4	4	4	4	4	4
NS	3000-1813BX	Reversing Valve Wiring Harness	X	X	X	X	X	X
NS	3000-1814BX	Dehum Valve Wiring Harness				X	X	X
NS	8620-343	UV-C Field Install Kit	0	0	0	0	0	0
NS	8620-370	AIR4 NBPI Field Install Kit	0	0	0	0	0	0

NS – Not Shown

X – Standard Component
O – Optional Component

EEV CONTROLLER ASSEMBLY

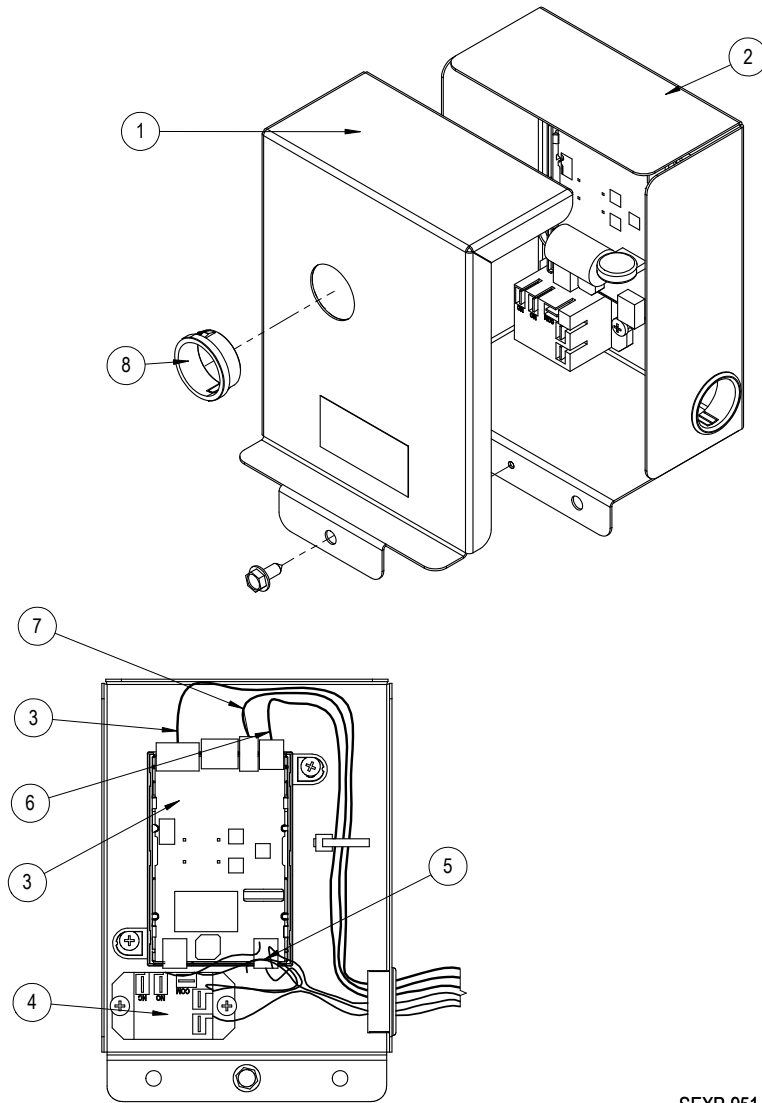

SEXP-951

910-2050-005BX

Dwg No.	Part Number	Description	
1	143-219BX	EEV Control Box Cover	X
2	127-572BX	EEV Control Box	X
3	8301-079-0005BX	EEV Control Module & Stator Cable	X
3	5651-246BX	EEV Stator Cable Only	X
4	8201-130BX	Control Relay	X
5	3000-1602BX	Main Wire Assembly	X
6	3000-1611BX	Transducer Wire Assembly – Connects to EEV Board	X
6	3000-1603BX	Transducer Wire Assembly – Connects to Transducer	X
7	8408-056BX	EEV Thermistor	X
8	8611-075	Clear Snap Plug	X

CONTROL PANEL – STANDARD & DEHUMIDIFICATION

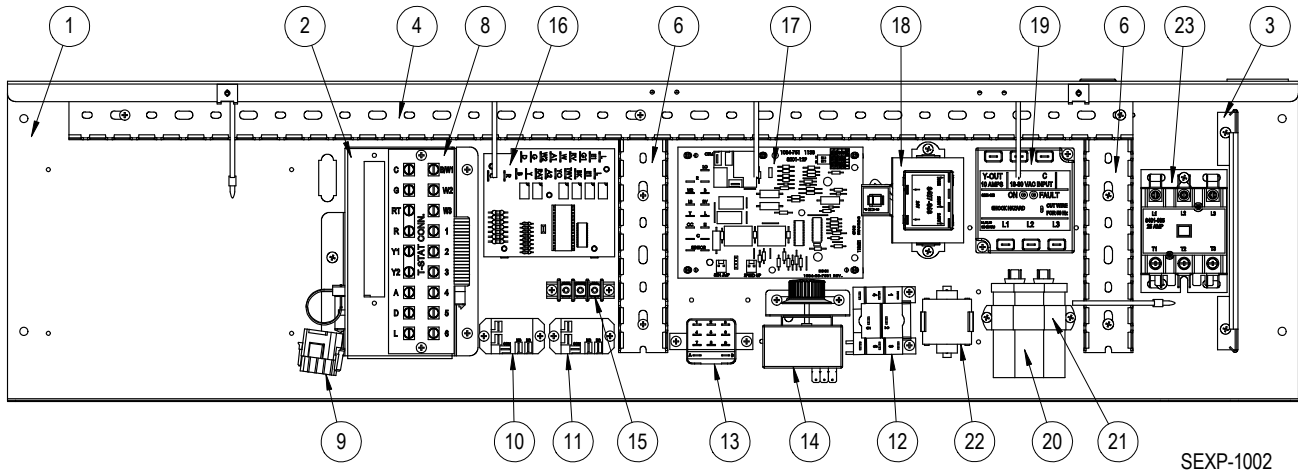

CONTROL PANEL – STANDARD & DEHUMIDIFICATION

Dwg No.	Part Number	Description	W42HF-A	W42HF-B	W42HF-C	W42HFDA	W42HFDB	W42HFDC	W48HF-A	W48HF-B	W48HF-C	W48HFDA	W48HFDB	W48HFDC	W60HF-A	W60HF-B	W60HF-C	W60HFDA	W60HFDB	W60HFDC
1	117-456BX	Control Panel	X	X	X	X	X	X	X	X	X	X	X	X	X	X	X	X	X	X
2	910-2061BX	Complete Low Voltage Box Assembly (Sheet metal, Terminal Strip, & Wire Harness)	X	X	X	X	X	X	X	X	X	X	X	X	X	X	X	X	X	X
3	135-394BX	Wire Shield	X	X	X	X	X	X	X	X	X	X	X	X	X	X	X	X	X	X
4	8611-244-3208BX	Cable Duct - 32.5"	X	X	X	X	X	X	X	X	X	X	X	X	X	X	X	X	X	X
6	8611-244-0608BX	Cable Duct - 6.5"	2	2	2	2	2	2	2	2	2	2	2	2	2	2	2	2	2	2
8	8607-063BX	Low Voltage Terminal Strip - 18 term.	X	X	X	X	X	X	X	X	X	X	X	X	X	X	X	X	X	X
9	3000-1524BX	Vent Jumper Plug (used when no vent option)	X	X	X	X	X	X	X	X	X	X	X	X	X	X	X	X	X	X
10	8201-130BX	Alarm Relay (Kit = CMC-35)	0	0	0	0	0	0	0	0	0	0	0	0	0	0	0	0	0	0
11	8201-130BX	Blower Speed Relay	X	X	X	X	X	X	X	X	X	X	X	X	X	X	X	X	X	X
12	8201-086BX	OD T-Stat/LAC Relay (LAC Kit = CMH-35)	0	0	0	0	0	0	0	0	0	0	0	0	0	0	0	0	0	0
13	8201-159BX	Dirty Filter Relay (Kit = CMC-33)	0	0	0	0	0	0	0	0	0	0	0	0	0	0	0	0	0	0
14	8408-028BX	Outdoor Thermostat (ODT Kit = CMH-36)	0	0	0	0	0	0	0	0	0	0	0	0	0	0	0	0	0	0
15	8607-042BX	Blower Speed Terminal Block	X	X	X	X	X	X	X	X	X	X	X	X	X	X	X	X	X	X
16	8201-113BX	Dehumidification Logic Board				X	X	X				X	X	X				X	X	X
17	8620-223	Defrost Logic Control Board w/Sensor	X	X	X	X	X	X	X	X	X	X	X	X	X	X	X	X	X	X
18	8407-068BX	Transformer	X	X		X	X		X	X		X	X		X	X		X	X	
18	8407-069BX	Transformer			X			X			X			X			X			X
19	8201-174BX	Phase Monitor		X	X		X	X		X	X		X	X		X	X		X	X
20	8552-004BX	Outdoor Motor Capacitor			X			X			X			X			X			X
20	8552-005BX	Outdoor Motor Capacitor		X				X			X			X			X			X
20	8552-058BX	Compressor Capacitor						X						X					X	
20	8552-079BX	Compressor Capacitor						X						X					X	
20	8552-080BX	Compressor Capacitor	X			X														
21	8550-003BX	Capacitor Strap 1-1/4" Oval		X	X		X	X		X	X		X	X		X	X		X	X
21	8550-008BX	Capacitor Strap 2-1/2" Round	X			X			X			X			X			X		X
21	8550-011BX	2-1/2 Single Hole Strap	X	X	X	X	X	X	X	X	X	X	X	X	X	X	X	X	X	X
21	8550-014BX	2-1/2 Single Hole Strap SS	0	0	0	0	0	0	0	0	0	0	0	0	0	0	0	0	0	0
22	8551-004BX	Start Device (PTCR) (Kit = CMC-32)	0			0			0			0			0			0		0
23	8401-033BX	Contact 2-Pole 20 Amp	X			X			X			X			X			X		X
23	8401-034BX	Contact 2-Pole 40 Amp	X			X			X			X			X			X		X
23	8401-035BX	Contact 3-Pole 25 Amp		X	X		X	X		X	X		X	X		X	X		X	X
NS	8615-038BX	Circuit Breaker 35A 2 Pole ①	0			0			0			0			0			0		0
NS	8615-039BX	Circuit Breaker 45A 2 Pole ①							0			0			0			0		0
NS	8615-042BX	Circuit Breaker 35A 3 Pole ①							0			0			0			0		0
NS	8615-052BX	Circuit Breaker 30A 3 Pole ①		0					0			0			0			0		0
NS	8615-095BX	Toggle Disconnect			0				0			0			0			0		0
NS	8615-047BX	Jumper Bar Base 4 Pole			X			X			X			X			X			X
NS	8615-049BX	Jumper Bar Cover 4 Pole			X			X			X			X			X			X
NS	4096-198	Wiring Diagram	X					X						X						
NS	4096-199	Wiring Diagram		X		X				X				X						
NS	4096-298	Wiring Diagram							X					X						
NS	4096-299	Wiring Diagram					X					X								
NS	4096-398	Wiring Diagram			X					X				X						
NS	4096-399	Wiring Diagram						X						X						
NS	4217-105	Wiring Diagram												X				X		
NS	4217-205	Wiring Diagram																	X	
NS	4217-305	Wiring Diagram																		X
NS	3000-1613BX	Blower Power Plug	X	X	X	X	X	X	X	X	X	X	X	X	X	X	X	X	X	X
NS	3000-1614BX	Blower Speed Plug	X	X	X	X	X	X	X	X	X	X	X	X	X	X	X	X	X	X
NS	3000-1222BX	Compressor Plug/Harness	X			X			X			X			X			X		X
NS	3000-1230BX	Compressor Plug/Harness		X	X		X	X		X	X		X	X		X	X		X	X
NS	3003-170BX	Control Panel Wire Harness	X						X					X						
NS	3003-171BX	Control Panel Wire Harness		X					X					X						
NS	3003-172BX	Control Panel Wire Harness			X					X				X						
NS	3003-173BX	Control Panel Wire Harness				X					X			X						
NS	3003-174BX	Control Panel Wire Harness					X					X		X						
NS	3003-175BX	Control Panel Wire Harness						X					X	X						
NS	3003-220BX	Control Panel Wire Harness												X						
NS	3003-221BX	Control Panel Wire Harness															X			X
NS	3003-222BX	Control Panel Wire Harness																	X	X
NS	3000-1524BX	Low Voltage Terminal Block Wire Harness	X	X	X	X	X	X	X	X	X	X	X	X	X	X	X	X	X	X
NS	8201-032BX	Outdoor Fan Relay (located where start device shown)			X			X			X			X			X			X

NS = Not Shown

① Circuit breakers listed are for units without electric heat, "OZ" models.
See heater replacement parts manual for units with electric heat.

X – Standard Component
O – Optional Component

BLOWER ASSEMBLY

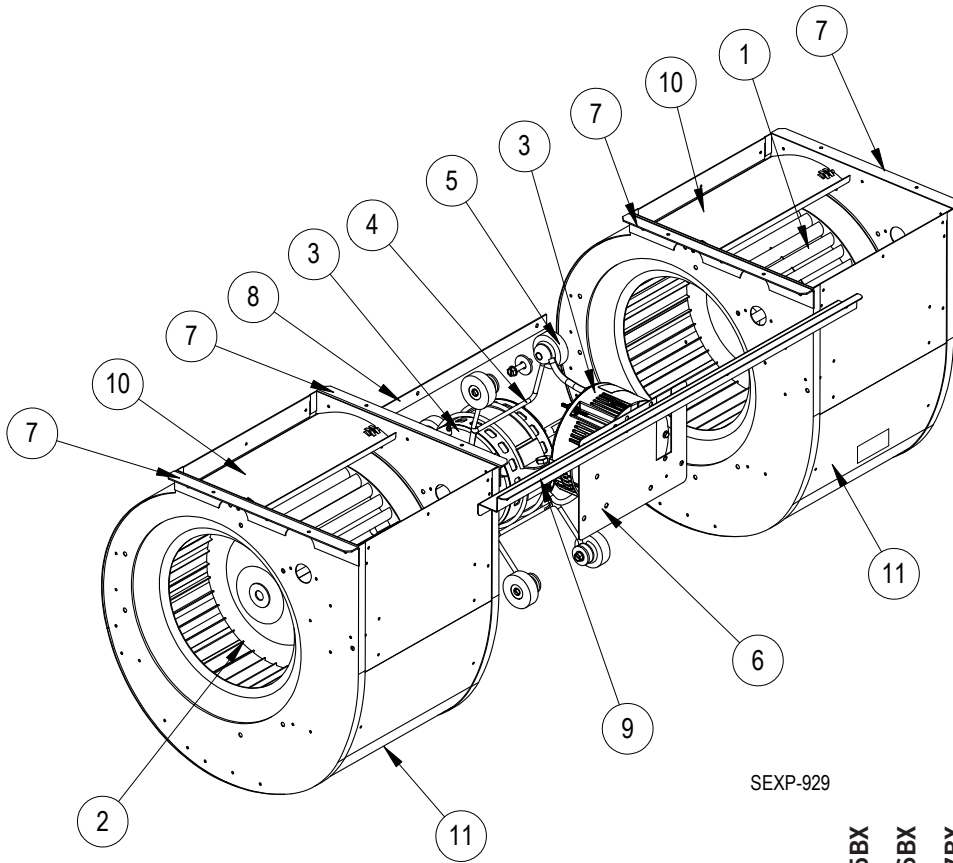

SEXP-929

Dwg No.	Part Number	Description	900-366-0185BX	900-367-0176BX	900-368-0177BX	900-368-0179BX	900-369-0178BX	900-369-0180BX
1	5152-011BX	10 Inch Wheel (CW)	X	X	X	X	X	X
2	5152-012BX	10 Inch Wheel (CCW)	X	X	X	X	X	X
3	8106-068-0158BX	Programmed Blower Motor & Control (230/208V)	X					
3	8106-069-0176BX	Programmed Blower Motor & Control (460V)		X				
3	8107-028-0177BX	Programmed Blower Motor & Control (230/208V)			X			
3	8107-028-0179BX	Programmed Blower Motor & Control (230/208V)				X		
3	8107-029-0178BX	Programmed Blower Motor & Control (460V)					X	
3	8107-029-0180BX	Programmed Blower Motor & Control (460V)						X
4	8200-040BX	Motor Mount	X	X	X	X	X	X
5	5451-011	Grommet	6	6	6	6	6	6
6	112-775BX	Motor Control Bracket	X	X	X	X	X	X
7	105-880BX	Side Angle	4	4	4	4	4	4
8	105-881BX	Back Brace	X	X	X	X	X	X
9	103-541BX	Front Mounting Offset	X	X	X	X	X	X
10	144-166BX	Diffuser	2	2	2	2	2	2
11	151-101BX	Blower Housing	2	2	2	2	2	2