REPLACEMENT PARTS MANUAL

Wall-Mounted Packaged Heat Pump

Models:

W30HF-A W36HF-A W30HFDA W36HFDA
W30HF-B W36HF-B W30HFDB W36HFDB
W30HF-C W36HF-C W30HFDC W36HFDC

Contents

Description	Page
Cabinet Components	
♦ Exploded View	2
♦ Usage List	3
♦ Usage List	4
Functional Components – Standard Units	
♦ Exploded View	6
♦ Usage List	7
Functional Components – Dehumidification Units	
♦ Exploded View	8
♦ Usage List	9
Control Panel – 230 Volt 1 Phase Units	
♦ Layout View	10
♦ Usage List	11
Control Panel – 230 Volt 3 Phase Units	
♦ Layout View	12
♦ Usage List	13
Control Panel – 460 Volt 3 Phase Units	
♦ Layout View	14
♦ Usage List	15

Description	Page
Blower Assembly	
♦ Exploded View	16
♦ Usage List	16
EEV Controller Assembly	
♦ Exploded View	17
♦ Usage List	17

General Notes

- Revised and/or additional pages may be issued from time to time.
- A complete and current manual consists of pages shown in the contents section.

Important

- Contact the installing and/or local Bard distributor for all parts requirements. Make sure to have the complete model and serial number available from the unit rating plates.



Bard Manufacturing Company, Inc.
Bryan, Ohio 43506
www.bardhvac.com

Manual: 2110-1591A
Supersedes: 2110-1591
Date: 9-23-25

CABINET COMPONENTS

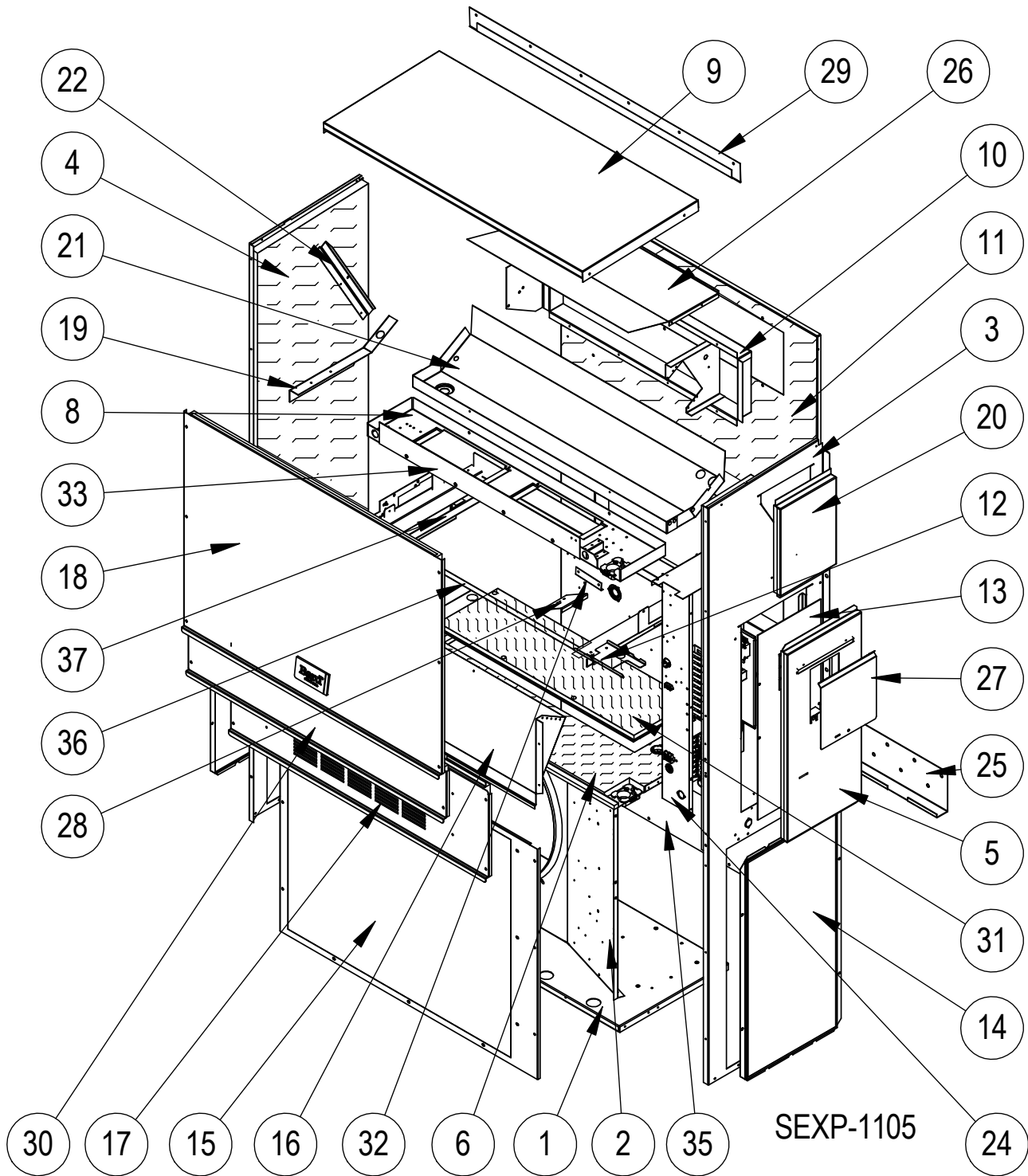

This drawing to be used for reference for pages 3 and 4

CABINET COMPONENTS

Dwg No.	Part Number	Description	W30HF-A, B	W30HF-C	W30HFDA, B	W30HFDC	W36HF-A, B	W36HF-C	W36HFDA, B	W36HFDC
1	127-471BX	Lower Base	X	X	X	X	X	X	X	X
1	127-528BX ②	Lower Base	X	X	X	X	X	X	X	X
2	125-081BX	Fan Shroud	X	X	X	X	X	X	X	X
2	125-083BX ②	Fan Shroud	X	X	X	X	X	X	X	X
3	501-1204-*BX ①	Right Side	X	X	X	X	X	X	X	X
3	501-1205BX ②	Right Side	X	X	X	X	X	X	X	X
3	501-1206BX ③	Right Side	X	X	X	X	X	X	X	X
4	501-1219-*BX ①	Left Side	X	X	X	X	X	X	X	X
4	501-1210BX ②	Left Side	X	X	X	X	X	X	X	X
4	501-1211BX ③	Left Side	X	X	X	X	X	X	X	X
5	533-228-*BX ①	Control Panel Cover (Outer)	X	X	X	X	X	X	X	X
5	533-235BX ②	Control Panel Cover (Outer)	X	X	X	X	X	X	X	X
5	533-236BX ③	Control Panel Cover (Outer)	X	X	X	X	X	X	X	X
6	521X527BX	Condenser Partition	X	X	X	X	X	X	X	X
6	521-552BX ②	Condenser Partition	X	X	X	X	X	X	X	X
8	121X467BX	Blower Partition	X	X	X	X	X	X	X	X
9	507-308-*BX ①	Top	X	X	X	X	X	X	X	X
9	507-319BX ②	Top	X	X	X	X	X	X	X	X
9	507-320BX ③	Top	X	X	X	X	X	X	X	X
10	111X030BX	Outlet Air Frame Assembly	X	X	X	X	X	X	X	X
11	509-451BX	Upper Back	X	X	X	X	X	X	X	X
11	509-455BX ②	Upper Back	X	X	X	X	X	X	X	X
11	509-453BX ③	Upper Back	X	X	X	X	X	X	X	X
12	137X1011BX	Filter Fill Plate	X	X	X	X	X	X	X	X
13	132-375BX	Control Panel Cover (Inner)	X		X		X		X	
13	132-385BX	Control Panel Cover (Inner)		X		X		X		X
14	118-124-*BX ①	Side Grille	2	2	2	2	2	2	2	2
14	118-140BX ②	Side Grille	2	2	2	2	2	2	2	2
14	118-141BX ③	Side Grille	2	2	2	2	2	2	2	2
15	118-103-*BX ①	Condenser Grille	X	X	X	X	X	X	X	X
15	118-108BX ②	Condenser Grille	X	X	X	X	X	X	X	X
15	118-145BX ③	Condenser Grille	X	X	X	X	X	X	X	X
16	BFAD-3	Fresh Air Damper Assembly	X	X	X	X	X	X	X	X
17	553-523-*BX ①	Vent Option Door	X	X	X	X	X	X	X	X
17	553-540-*BX ①	Vent Option Door with ERV	X	X	X	X	X	X	X	X
17	553-665-*BX ①	Vent Option Door with CRV or ECON-S	X	X	X	X	X	X	X	X
17	553-549BX ②	Vent Option Door	X	X	X	X	X	X	X	X
17	553-557BX ②	Vent Option Door with ERV	X	X	X	X	X	X	X	X
17	553-694BX ②	Vent Option Door with CRV or ECON-S	X	X	X	X	X	X	X	X
17	553-550BX ③	Vent Option Door	X	X	X	X	X	X	X	X
17	553-558BX ③	Vent Option Door with ERV	X	X	X	X	X	X	X	X
17	553-695BX ③	Vent Option Door with CRV or ECON-S	X	X	X	X	X	X	X	X
18	514-241-*BX ①	Upper Front	X	X	X	X	X	X	X	X
18	514-238BX ②	Upper Front	X	X	X	X	X	X	X	X
18	514-239BX ③	Upper Front	X	X	X	X	X	X	X	X
19	105X850BX	Side Support	X	X	X	X	X	X	X	X

Continued on page 4

- ① Exterior cabinet parts are manufactured with various paint color options. To ensure the proper paint color is received, include the complete model and serial number of the unit for which cabinet parts are being ordered.
- ② Exterior cabinet parts are manufactured from stainless steel Code "S"
- ③ Exterior cabinet parts are manufactured from aluminum Code "A"

CABINET COMPONENTS

Dwg. No.	Part Number	Description	W30HF-A, B	W30HF-C	W30HFDA, B	W30HFDC	W36HF-A, B	W36HF-C	W36HFDA, B	W36HFDC
<i>Continued from page 3</i>										
20	543-175-*BX ①	Right Side Cover Plate (Outer)	X	X	X	X	X	X	X	X
20	543-185BX ②	Right Side Cover Plate (Outer)	X	X	X	X	X	X	X	X
20	543-184BX ③	Right Side Cover Plate (Outer)	X	X	X	X	X	X	X	X
21	123-127BX	Drain Pan	X	X	X	X	X	X	X	X
21	123-141BX ②③	Drain Pan	X	X	X	X	X	X	X	X
22	147-044BX	Evaporator Support	X	X	X	X	X	X	X	X
24	Control Panel Assembly	See Control Panel on pages 10 – 15	X	X	X	X	X	X	X	X
25	113-140BX	Bottom Mounting Bracket	X	X	X	X	X	X	X	X
26	135X123BX	Heat Shield	X	X	X	X	X	X	X	X
27	153-218-*BX ①	Disconnect Access Door	X	X	X	X	X	X	X	X
27	153-405BX ②	Disconnect Access Door	X	X	X	X	X	X	X	X
27	153-387BX ③	Disconnect Access Door	X	X	X	X	X	X	X	X
28	131-194BX	Fill Partition Bracket	X	X	X	X	X	X	X	X
29	113-149-*BX ①	Top Rain Flashing	X	X	X	X	X	X	X	X
29	113-360BX ②	Top Rain Flashing	X	X	X	X	X	X	X	X
29	113-149-4BX ③	Top Rain Flashing	X	X	X	X	X	X	X	X
30	553-524-*BX ①	Filter Door	X	X	X	X	X	X	X	X
30	553-553BX ②	Filter Door	X	X	X	X	X	X	X	X
30	553-554BX ③	Filter Door	X	X	X	X	X	X	X	X
31	536-498BX	Cond. Partition Block Off Plate	X	X	X	X	X	X	X	X
31	536-877BX ②	Cond. Partition Block Off Plate	X	X	X	X	X	X	X	X
32	105-1302	Grommet Retainer	X	X	X	X	X	X	X	X
33	135-329BX	Air Baffle	X	X	X	X	X	X	X	X
35	109-450BX	Lower Back	X	X	X	X	X	X	X	X
35	109-454BX ②	Lower Back	X	X	X	X	X	X	X	X
35	109-452BX ③	Lower Back	X	X	X	X	X	X	X	X
36	131-190BX	Filter Tray Angle	X	X	X	X	X	X	X	X
37	131X189BX	Filter Partition	X	X	X	X	X	X	X	X
NS	5252-033	Bard Nameplate	X	X	X	X	X	X	X	X

① Exterior cabinet parts are manufactured with various paint color options. To ensure the proper paint color is received, include the complete model and serial number of the unit for which cabinet parts are being ordered.

② Exterior cabinet parts are manufactured from stainless steel Code "S"

③ Exterior cabinet parts are manufactured from aluminum Code "A"

Refer to drawing on page 2

This page intentionally left blank

FUNCTIONAL COMPONENTS – STANDARD UNITS

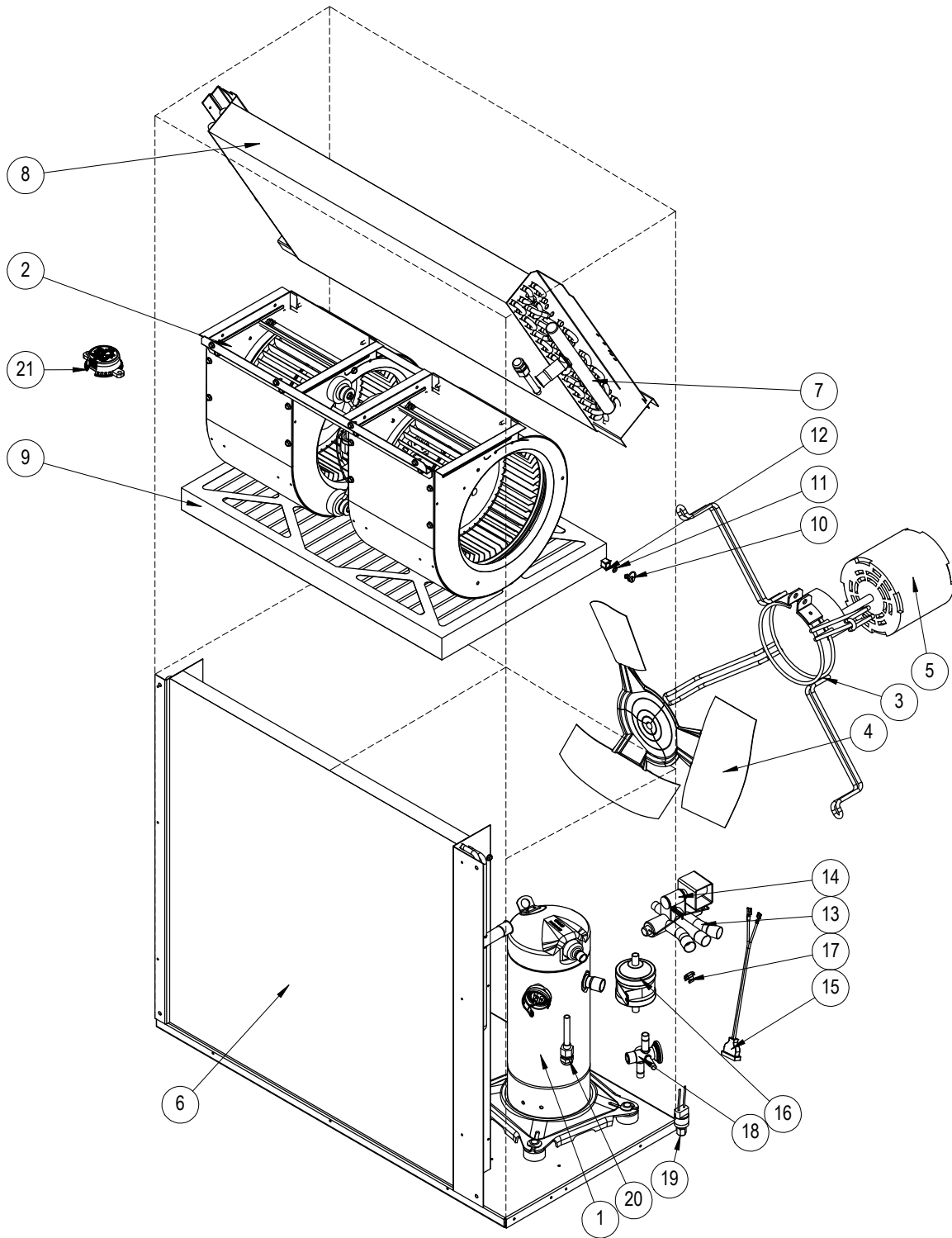

SEXP-985 A

FUNCTIONAL COMPONENTS – STANDARD UNITS

Dwg No.	Part Number	Description	W30HF-A	W30HF-B	W30HF-C	W36HF-A	W36HF-B	W36HF-C
1	8000-490BX	Compressor	X					
1	8000-491BX	Compressor		X				
1	8000-492BX	Compressor			X			
1	8000-494BX	Compressor				X		
1	8000-495BX	Compressor					X	
1	8000-496BX	Compressor						X
NS	3000-1224BX	Molded Compressor Wire Harness (1-PH)	X			X		
NS	3000-1231BX	Molded Compressor Wire Harness (3-PH)		X	X		X	X
2	900-360-0171BX	Blower Assembly	X	X				
2	900-361-0172BX	Blower Assembly			X			
2	900-360-0173BX	Blower Assembly				X	X	
2	900-361-0174BX	Blower Assembly						X
3	8200-001BX	Fan Motor Mount	X	X	X	X	X	X
3	8200-050BX ①	Stainless Steel Fan Motor Mount	X	X	X	X	X	X
4	5151-045BX	Fan Blade	X	X	X	X	X	X
4	5151C045BX ①	Coated Fan Blade	X	X	X	X	X	X
5	8103-029BX	Outdoor Fan Motor	X	X		X	X	
5	8103-030BX	Outdoor Fan Motor			X			X
6	917-0320BX	Outdoor Coil (Includes Distributor)	X	X	X			
6	917-0321BX ②	Outdoor Coil – Coated (Includes Distributor)	O	O	O			
6	917-0387BX	Outdoor Coil (Includes Distributor)				X	X	X
6	917-0392BX ②	Outdoor Coil – Coated (Includes Distributor)				O	O	O
7	800-0506BX	Cooling Distributor Assembly	X	X	X			
7	800-0507BX	Cooling Distributor Assembly				X	X	X
8	917-0527BX	Indoor Coil (Includes Cooling Distributor)	X	X	X			
8	917-0528BX ②	Indoor Coil – Coated (Includes Cooling Distributor)	O	O	O			
8	917-0544BX	Indoor Coil (Includes Cooling Distributor)				X	X	X
8	917-0545BX ②	Indoor Coil – Coated (Includes Cooling Distributor)				O	O	O
9	7004-019	Air Filter 1" Disposable	X	X	X	X	X	X
9	7003-031 ②	Air Filter 1" Washable	O	O	O	O	O	O
9	7004-026 ②	Air Filter 2" Pleated Disposable	O	O	O	O	O	O
10	1171-022	1/4 Turn Fastener	X	X	X	X	X	X
11	1171-024	1/4 Turn Retainer	X	X	X	X	X	X
12	1171-023	1/4 Turn Receptacle	X	X	X	X	X	X
13	5650-039BX	Reversing Valve w/24V Solenoid Coil	X	X	X	X	X	X
14	5650-046BX	Reversing Valve 24V Solenoid	X	X	X	X	X	X
15	5650-044BX	Molded Plug 53" Lead	X	X	X	X	X	X
16	5201-019BX	Filter Drier, Bi-Directional, 3/8" Connections	X	X	X	X	X	X
17	8620-224	Defrost Sensor Kit	X	X	X	X	X	X
18	5651-254BX	Heating Expansion Valve	X	X	X	X	X	X
19	8406-167BX	High Pressure Switch (615#) Screw On	X	X	X	X	X	X
20	800-0474BX	Heating Distributor Assembly	X	X	X			
20	800-0426BX	Heating Distributor Assembly				X	X	X
21	8301-110BX	RDS Sensor	X	X	X	X	X	X
NS	8401-036BX	RDS Relay	X	X	X	X	X	X
NS	8406-168BX	Low Pressure Switch (20#) Screw On	X	X	X	X	X	X
NS	6031-009	Coremax Valve Core (Service Port)	2	2	2	2	2	2
NS	8406-105BX ②	Low Ambient Fan Cycling Control (350#/225#)	O	O	O	O	O	O
NS	8408-028BX ②	Outdoor Thermostat	O	O	O	O	O	O
NS	1171-028	Filter Door Clip	X	X	X	X	X	X
NS	1171-057	Filter Door Screw	X	X	X	X	X	X
NS	1171-027	Filter Door Screw Retainer	X	X	X	X	X	X

NS – Not Shown

① – Used with stainless steel cabinet option

② – Optional on these models

X – Standard

O – Add-On Option

Manual 2110-1591A

Page

7 of 17

FUNCTIONAL COMPONENTS – DEHUMIDIFICATION UNITS

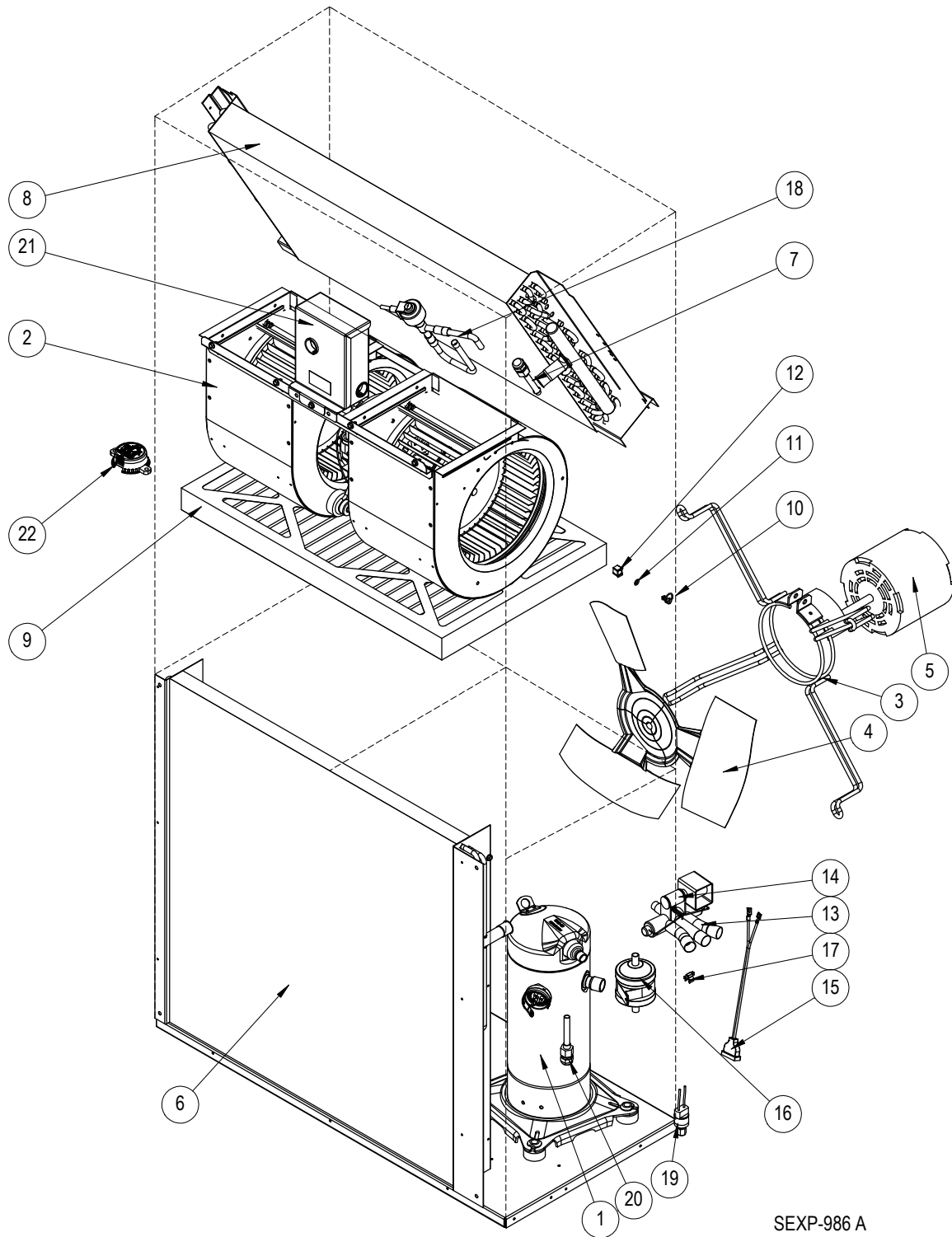

SEXP-986 A

FUNCTIONAL COMPONENTS – DEHUMIDIFICATION UNITS

Dwg No.	Part Number	Description	W30HFDA	W30HFDB	W30HFDC	W36HFDA	W36HFDB	W36HFDC
1	8000-490BX	Compressor	X					
1	8000-491BX	Compressor		X				
1	8000-492BX	Compressor			X			
1	8000-494BX	Compressor				X		
1	8000-495BX	Compressor					X	
1	8000-496BX	Compressor						X
NS	3000-1224BX	Molded Compressor Wire Harness (1-PH)	X			X		
NS	3000-1231BX	Molded Compressor Wire Harness (3-PH)		X	X		X	X
2	900-360-0171BX	Blower Assembly	X	X				
2	900-361-0172BX	Blower Assembly			X			
2	900-360-0173BX	Blower Assembly				X	X	
2	900-361-0174BX	Blower Assembly						X
3	8200-001BX	Fan Motor Mount	X	X	X	X	X	X
3	8200-050BX ①	Stainless Steel Fan Motor Mount	X	X	X	X	X	X
4	5151-045BX	Fan Blade	X	X	X	X	X	X
4	5151C045BX ①	Coated Fan Blade	X	X	X	X	X	X
5	8103-029BX	Outdoor Fan Motor	X	X		X	X	
5	8103-030BX	Outdoor Fan Motor			X			X
6	917-0320BX	Outdoor Coil (Includes Distributor)	X	X	X			
6	917-0321BX ②	Outdoor Coil – Coated (Includes Distributor)	O	O	O			
6	917-0387BX	Outdoor Coil (Includes Distributor)				X	X	X
6	917-0392BX ②	Outdoor Coil – Coated (Includes Distributor)				O	O	O
7	800-0460BX	Cooling Distributor Assembly	X	X	X	X	X	X
8	917-0384BX	Indoor Coil (Includes Cooling Distributor)	X	X	X	X	X	X
8	917-0396BX ②	Indoor Coil – Coated (Includes Cooling Distributor)	O	O	O	O	O	O
9	7004-019	Air Filter 1" Disposable	X	X	X	X	X	X
9	7003-031 ②	Air Filter 1" Washable	O	O	O	O	O	O
9	7004-026 ②	Air Filter 2" Pleated Disposable	O	O	O	O	O	O
10	1171-022	1/4 Turn Fastener	X	X	X	X	X	X
11	1171-024	1/4 Turn Retainer	X	X	X	X	X	X
12	1171-023	1/4 Turn Receptacle	X	X	X	X	X	X
13	5650-039BX	Reversing Valve w/24V Solenoid Coil	X	X	X	X	X	X
14	5650-046BX	Reversing Valve 24V Solenoid	X	X	X	X	X	X
15	5650-044BX	Molded Plug 53" Lead	X	X	X	X	X	X
16	5201-019BX	Filter Drier, Bi-Directional, 3/8" Connections	X	X	X	X	X	X
17	8620-224	Defrost Sensor Kit	X	X	X	X	X	X
18	5651S245BX	Electronic Expansion Valve	X	X	X	X	X	X
18	905-0732BX	Electronic Expansion Valve Assembly	X	X	X	X	X	X
19	8406-167BX	High Pressure Switch (615#) Screw On	X	X	X	X	X	X
20	800-0474BX	Heating Distributor Assembly	X	X	X			
20	800-0426BX	Heating Distributor Assembly				X	X	X
21	EEV Controller Assy.	See EEV CONTROLLER ASSEMBLY on page 17	X	X	X	X	X	X
22	8301-110BX	RDS Sensor	X	X	X	X	X	X
NS	8401-036BX	RDS Relay	X	X	X	X	X	X
NS	8406-168BX	Low Pressure Switch (20#) Screw On	X	X	X	X	X	X
NS	8406-158BX	Low Pressure Transducer	X	X	X	X	X	X
NS	3000-1603BX	Transducer Wire Assembly – Connects to Transducer	X	X	X	X	X	X
NS	6031-009	Coremax Valve Core (Service Port)	2	2	2	2	2	2
NS	5650-051BX	Dehumidification Mode Valve	X	X	X	X	X	X
NS	5651-219BX	Dehumidification Check Valves	2	2	2	2	2	2
NS	8406-105BX ②	Low Ambient Fan Cycling Control (350#/225#)	O	O	O	O	O	O
NS	8408-028BX ②	Outdoor Thermostat	O	O	O	O	O	O
NS	1171-028	Filter Door Clip	X	X	X	X	X	X
NS	1171-057	Filter Door Screw	X	X	X	X	X	X
NS	1171-027	Filter Door Screw Retainer	X	X	X	X	X	X

NS – Not Shown

① – Used with stainless steel cabinet option

② – Optional on these models

X – Standard

O – Add-On Option

Manual 2110-1591A

Page

9 of 17

CONTROL PANEL - 230 VOLT 1 PHASE UNITS

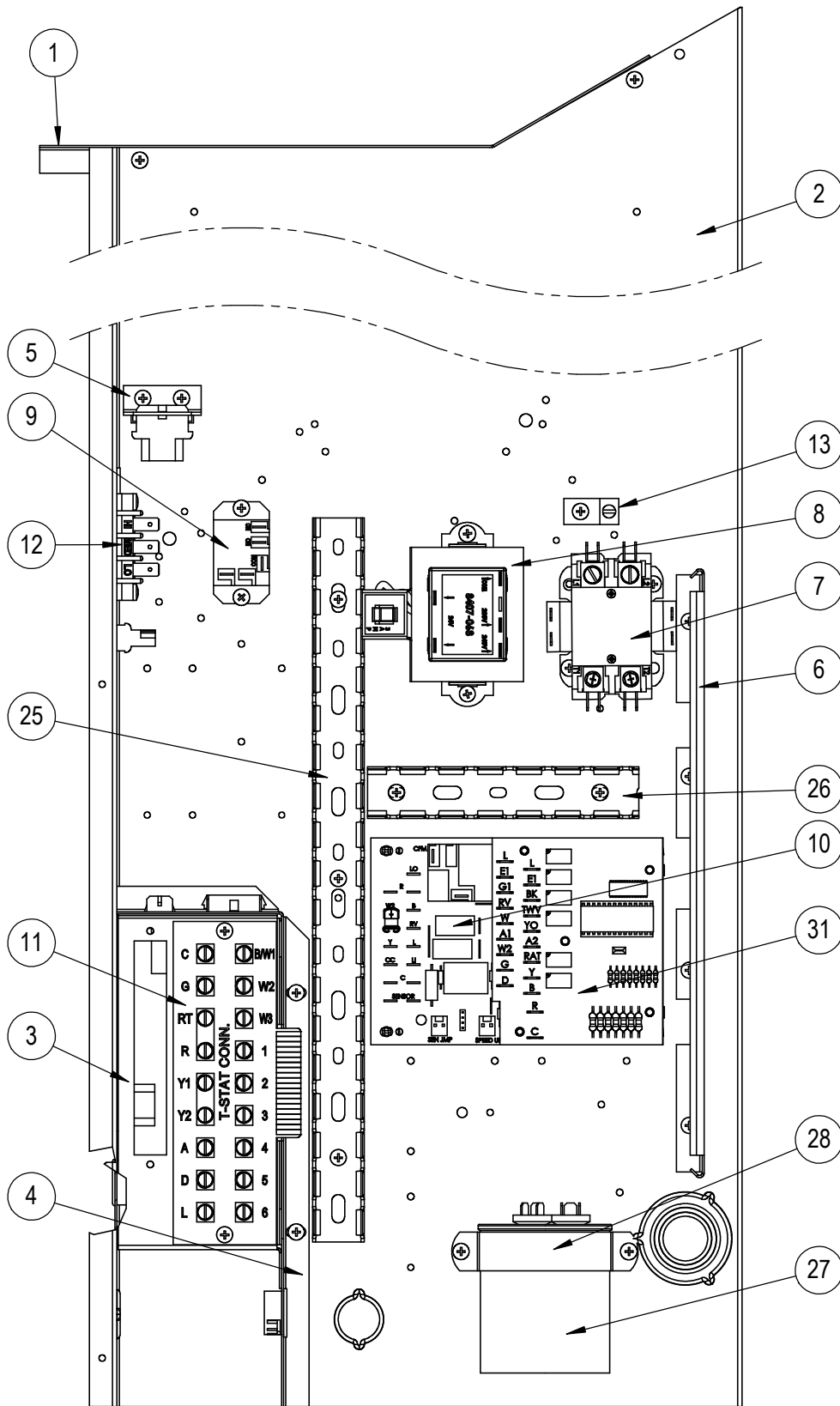

SEXP-987

CONTROL PANEL – 230 VOLT 1 PHASE UNITS

Dwg No.	Part Number	Description	W30HF-A	W30HFDA	W36HF-A	W36HFDA
1	117X137BX	Control Panel Top - RH (Sheet Metal Only)	X	X	X	X
2	117X447BX	Control Panel - RH (Sheet Metal Only)	X	X	X	X
3	117X375BX	Low Voltage Box - RH (Sheet Metal Only)	X	X	X	X
4	117X385BX	Low Voltage Partition - RH (Sheet Metal Only)	X	X	X	X
NS	3000-1494BX	Low Voltage Wire Harness (behind LVTS)	X	X	X	X
NS	910-2047BX	Complete Low Voltage Box Assembly (Sheet Metal, LVTS & Wire Harness)	X	X	X	X
5	141-596BX	Plug Support Bracket (Sheet Metal)	X	X	X	X
6	135-122BX	Wire Shield (Sheet Metal)	X	X	X	X
7	8401-033BX	Contactora 2-Pole	X	X	X	X
8	8407-068BX	Transformer 208/240-24, 50VA	X	X	X	X
9	8201-130BX	Relay, SPDT	X	X	X	X
10	8620-223	Defrost Board Replacement Kit w/Sensor	X	X	X	X
11	8607-044BX	Blower Speed Strip	X	X	X	X
12	8607-042BX	Blower Speed Terminal	X	X	X	X
13	8611-006	Ground Lug	X	X	X	X
25	8611-140-1400	14" Cable Duct	X	X	X	X
26	8611-140-0500	5" Cable Duct	X	X	X	X
27	8552-052BX	Capacitor 45+5/370 V, 2-1/2" Round	X	X	X	X
28	8550-008	Capacitor Strap, 2-1/2" Round	X	X	X	X
31	8201-113BX	Dehumidification Logic Control Board		X		X
NS	3003-156BX	Main Control Panel Wire Harness	X		X	
NS	3003-159BX	Main Control Panel Wire Harness		X		X
NS	8201-086BX	LAC and/or ODT Relay (Opt.)	0	0	0	0
NS	8408-028BX	Outdoor Thermostat (Opt.)	0	0	0	0
NS	3000-1598BX	Blower Power Plug	X	X	X	X
NS	3000-1599BX	Blower Speed Plug	X	X	X	X
NS	4096-195	Wiring Diagram	X			
NS	4096-196	Wiring Diagram		X		
NS	4096-198	Wiring Diagram			X	
NS	4096-194	Wiring Diagram				X
NS	3000-1252 ①	Electric Heat Jumper Plug	X	X	X	X
NS	8615-036BX ②	Circuit Breaker 25A 2 Pole (Opt.)	X	X		
NS	8615-038BX ②	Circuit Breaker 35A 2 Pole (Opt.)			X	X

NS – Not Shown

① Only on units without electric heat

② Circuit breakers listed are for units without electric heat, "OZ" models. See heater replacement parts manual for units with electric heat.

X – Standard

0 – Add-On Option

CONTROL PANEL - 230 VOLT 3 PHASE UNITS

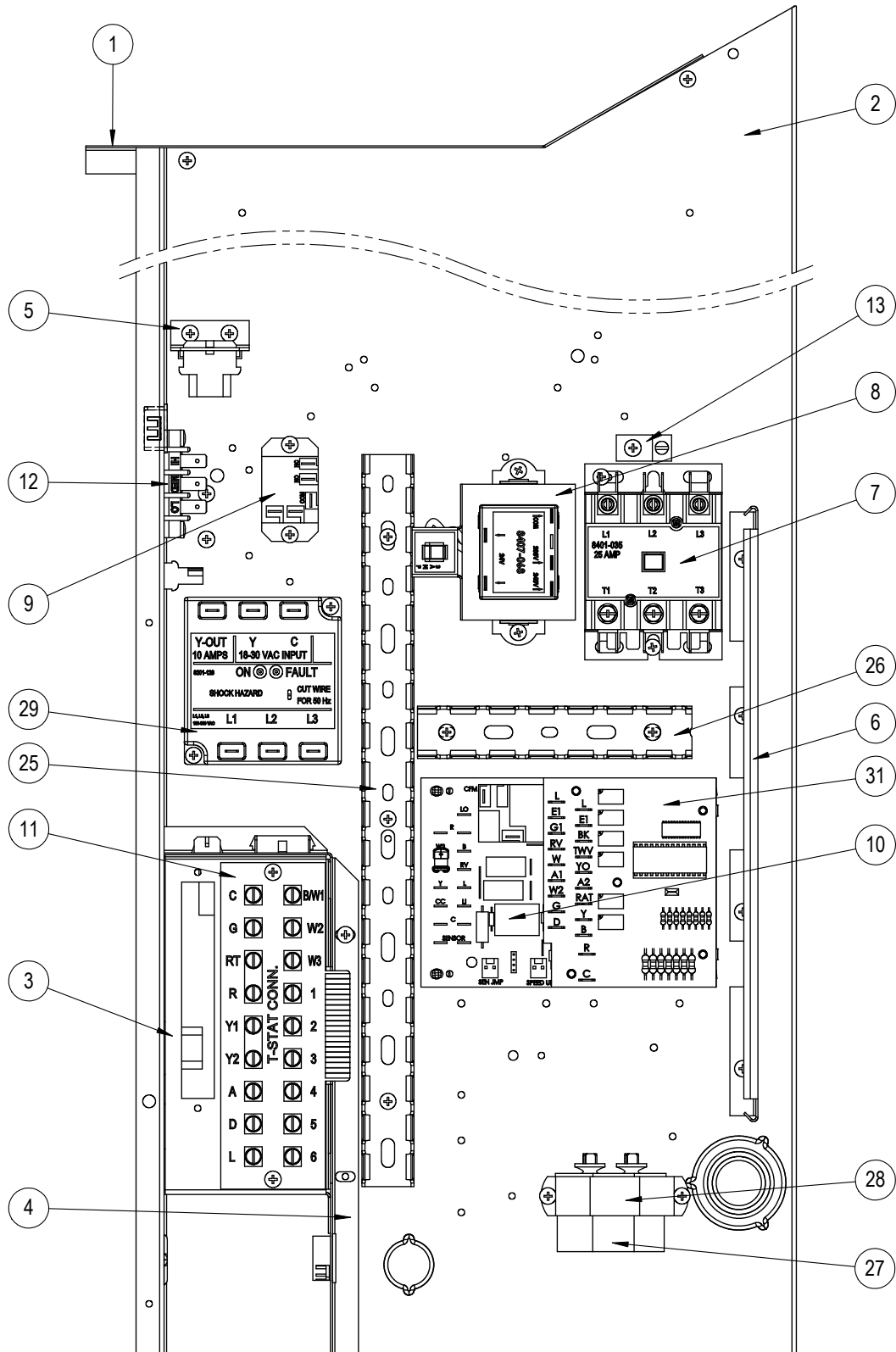

SEXP-988

CONTROL PANEL – 230 VOLT 3 PHASE UNITS

Dwg No.	Part Number	Description	W30HF-B	W30HFDB	W36HF-B	W36HFDB
1	117X137BX	Control Panel Top - RH (Sheet Metal Only)	X	X	X	X
2	117X447BX	Control Panel - RH (Sheet Metal Only)	X	X	X	X
3	117X375BX	Low Voltage Box - RH (Sheet Metal Only)	X	X	X	X
4	117X385BX	Low Voltage Partition - RH (Sheet Metal Only)	X	X	X	X
NS	3000-1494BX	Low Voltage Wire Harness (behind LVTS)	X	X	X	X
NS	910-2047BX	Complete Low Voltage Box Assembly (Sheet Metal, LVTS & Wire Harness)	X	X	X	X
5	141-596BX	Plug Support Bracket (Sheet Metal)	X	X	X	X
6	135-122BX	Wire Shield (Sheet Metal)	X	X	X	X
7	8401-035BX	Contactora 3-Pole	X	X	X	X
8	8407-068BX	Transformer 208/240-24, 50VA	X	X	X	X
9	8201-130BX	Relay, SPDT	X	X	X	X
10	8620-223	Defrost Board Replacement Kit w/Sensor	X	X	X	X
11	8607-044BX	Terminal Strip	X	X	X	X
12	8607-042BX	Blower Speed Terminal	X	X	X	X
13	8611-006	Ground Lug	X	X	X	X
25	8611-140-1400	14" Cable Duct	X	X	X	X
26	8611-140-0500	5" Cable Duct	X	X	X	X
27	8552-002BX	Capacitor 5/370 V, 1-1/4" Oval	X	X	X	X
28	8550-003	Capacitor Strap, 1-1/4" Oval	X	X	X	X
29	8201-174BX	3 Phase Line Monitor	X	X	X	X
31	8201-113BX	Dehumidification Logic Control Board		X		X
NS	3003-157BX	Main Control Panel Wire Harness	X		X	
NS	3003-160BX	Main Control Panel Wire Harness		X		X
NS	8201-086BX	LAC and/or ODT Accessory Relay (Opt.)	0	0	0	0
NS	8408-028BX	Outdoor Thermostat (Opt.)	0	0	0	0
NS	3000-1598BX	Blower Power Plug	X	X	X	X
NS	3000-1599BX	Blower Speed Plug	X	X	X	X
NS	4096-295	Wiring Diagram	X			
NS	4096-296	Wiring Diagram		X		
NS	4096-293	Wiring Diagram			X	
NS	4096-294	Wiring Diagram				X
NS	3000-1252 ①	Electric Heat Jumper Plug	X	X	X	X
NS	8615-054BX ②	Circuit Breaker 20A 3 Pole (Opt.)	X			
NS	8615-051BX ②	Circuit Breaker 25A 3 Pole (Opt.)		X	X	X

NS – Not Shown

① Only on units without electric heat

② Circuit breakers listed are for units without electric heat, "OZ" models. See heater replacement parts manual for units with electric heat.

X – Standard

0 – Add-On Option

CONTROL PANEL - 460 VOLT 3 PHASE UNITS

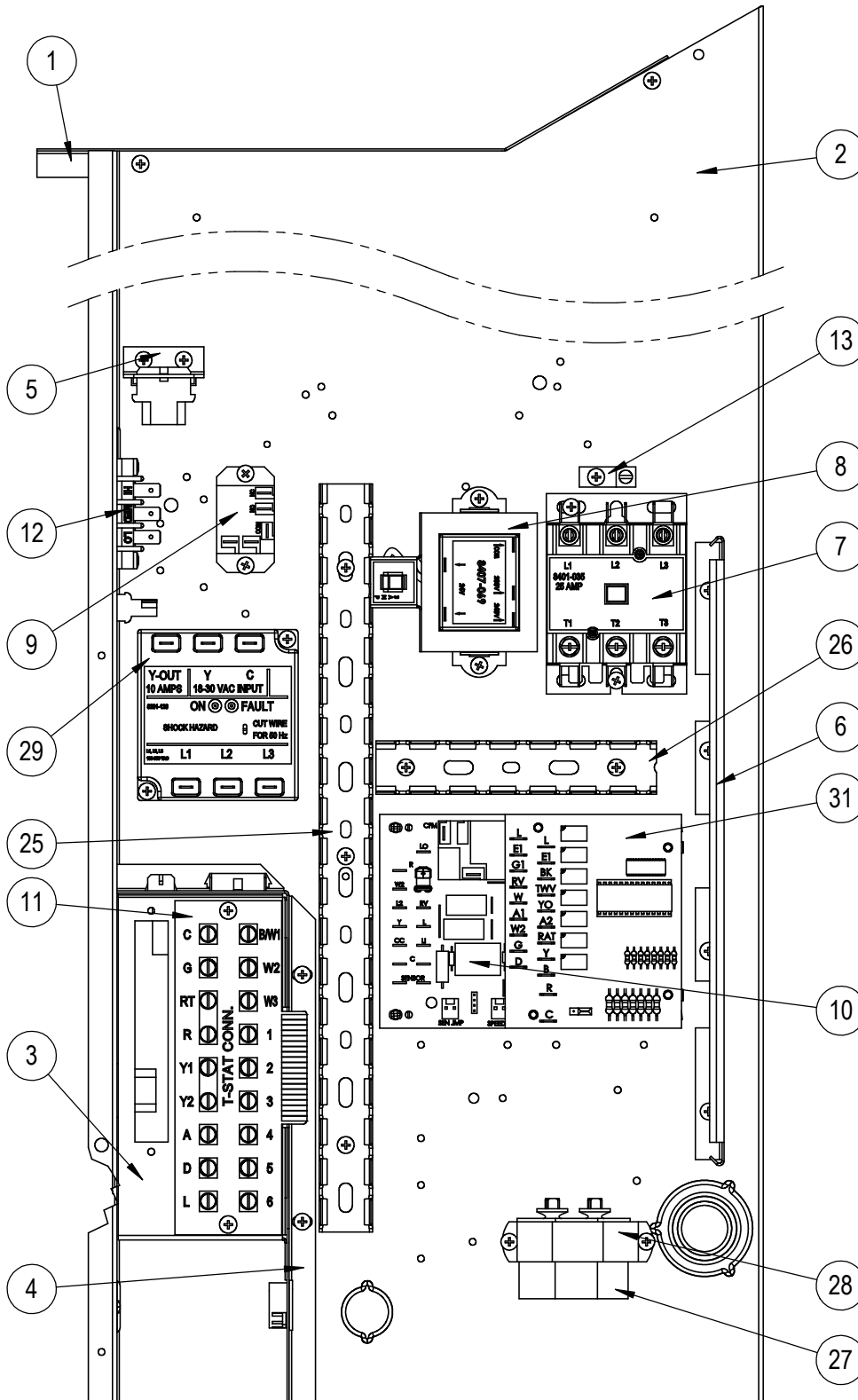

SEXP-989

CONTROL PANEL – 460 VOLT 3 PHASE UNITS

Dwg No.	Part Number	Description	W30HF-C	W30HFDC	W36HF-C	W36HFDC
1	117X137BX	Control Panel Top - RH (Sheet Metal Only)	X	X	X	X
2	117X447BX	Control Panel - RH (Sheet Metal Only)	X	X	X	X
3	117X375BX	Low Voltage Box - RH (Sheet Metal Only)	X	X	X	X
4	117X385BX	Low Voltage Partition - RH (Sheet Metal Only)	X	X	X	X
NS	3000-1494BX	Low Voltage Wire Harness (behind LVTS)	X	X	X	X
NS	910-2047BX	Complete Low Voltage Box Assembly (Sheet Metal, LVTS & Wire Harness)	X	X	X	X
5	141-596BX	Plug Support Bracket (Sheet Metal)	X	X	X	X
6	135-122BX	Wire Shield (Sheet Metal)	X	X	X	X
7	8401-035BX	Contactors 3-Pole	X	X	X	X
8	8407-069BX	Transformer 460-24, 50VA	X	X	X	X
9	8201-032BX	Relay, SPDT, 3 FLA@480V	X	X	X	X
10	8620-223	Defrost Board Replacement Kit w/Sensor	X	X	X	X
11	8607-044BX	Terminal Strip	X	X	X	X
12	8607-042BX	Blower Speed Terminal	X	X	X	X
13	8611-006	Ground Lug	X	X	X	X
25	8611-140-1400	14" Cable Duct	X	X	X	X
26	8611-140-0500	5" Cable Duct	X	X	X	X
27	8552-002BX	Capacitor 5/370 V, 1-1/4" Oval	X	X	X	X
28	8550-003	Capacitor Strap, 1-1/4" Oval	X	X	X	X
29	8201-174BX	3 Phase Line Monitor	X	X	X	X
31	8201-113BX	Dehumidification Logic Control Board		X		X
NS	3003-158BX	Main Control Panel Wire Harness	X		X	
NS	3003-161BX	Main Control Panel Wire Harness		X		X
NS	8201-086BX	LAC and/or ODT Accessory Relay (Opt.)	O	O	O	O
NS	8408-028BX	Outdoor Thermostat (Opt.)	O	O	O	O
NS	3000-1598BX	Blower Power Plug	X	X	X	X
NS	3000-1599BX	Blower Speed Plug	X	X	X	X
NS	4096-395	Wiring Diagram	X			
NS	4096-396	Wiring Diagram		X		
NS	4096-393	Wiring Diagram			X	
NS	4096-394	Wiring Diagram				X
NS	3000-1252 ①	Electric Heat Jumper Plug	X	X	X	X
NS	8615-095BX ②	Toggle Disconnect (Opt.)	X	X	X	X

NS – Not Shown

① Only on units without electric heat

② Circuit breakers listed are for units without electric heat, "OZ" models. See heater replacement parts manual for units with electric heat.

X – Standard

O – Add-On Option

BLOWER ASSEMBLY

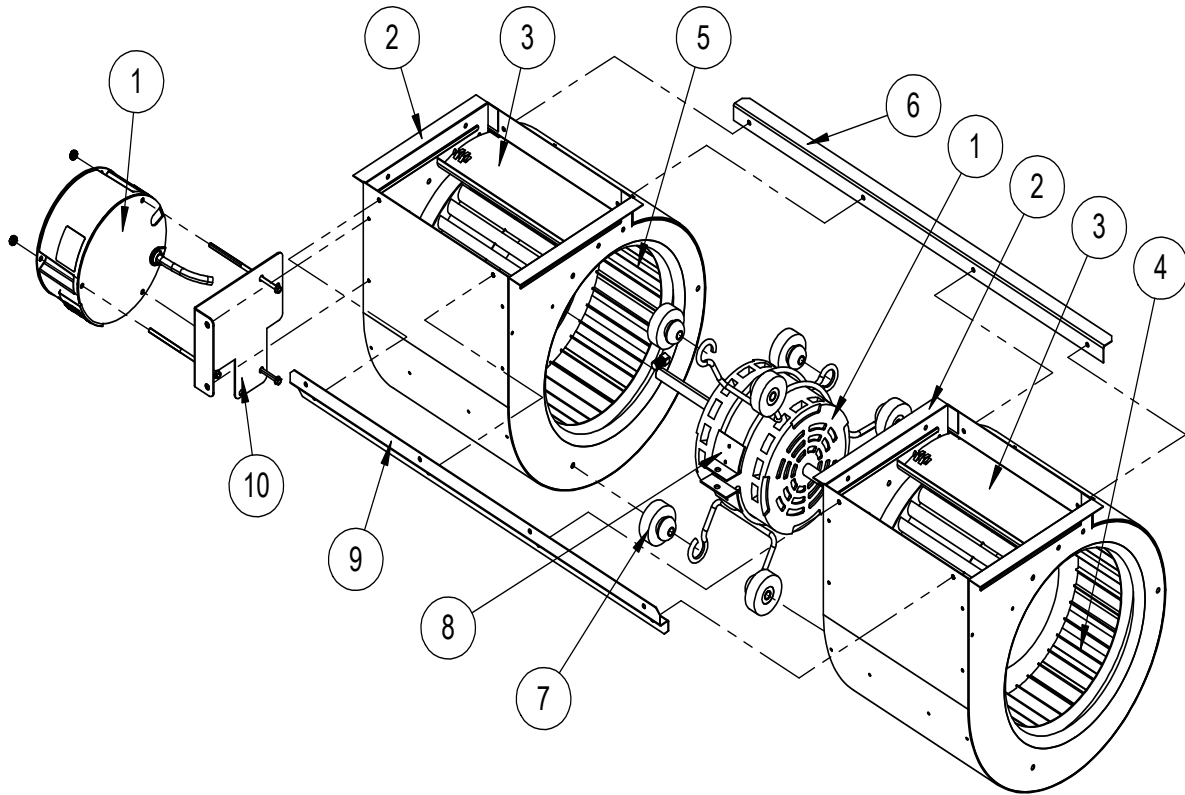

SEXP-909

Dwg No.	Part Number	Description	900-360-0171BX	900-361-0172BX	900-360-0173BX	900-361-0174BX
1	8106-068-0171BX	Blower Motor & Control (230/208V)	X			
1	8106-069-0172BX	Blower Motor & Control (460V)		X		
1	8106-068-0173BX	Blower Motor & Control (230/208V)			X	
1	8106-069-0174BX	Blower Motor & Control (460V)				X
2	151-111BX	Housing	2	2	2	2
3	144-174BX	Diffuser	X	X	X	X
4	5152-090BX	Wheel CW	X	X	X	X
5	5152-091BX	Wheel CCW	X	X	X	X
6	105-870BX	Back Brace	X	X	X	X
7	5451-011	Grommets	6	6	6	6
8	8200-031BX	Motor Mount	X	X	X	X
9	103-401BX	Front Brace	X	X	X	X
10	113-721BX	Motor Control Bracket	X	X	X	X

EEV CONTROLLER ASSEMBLY

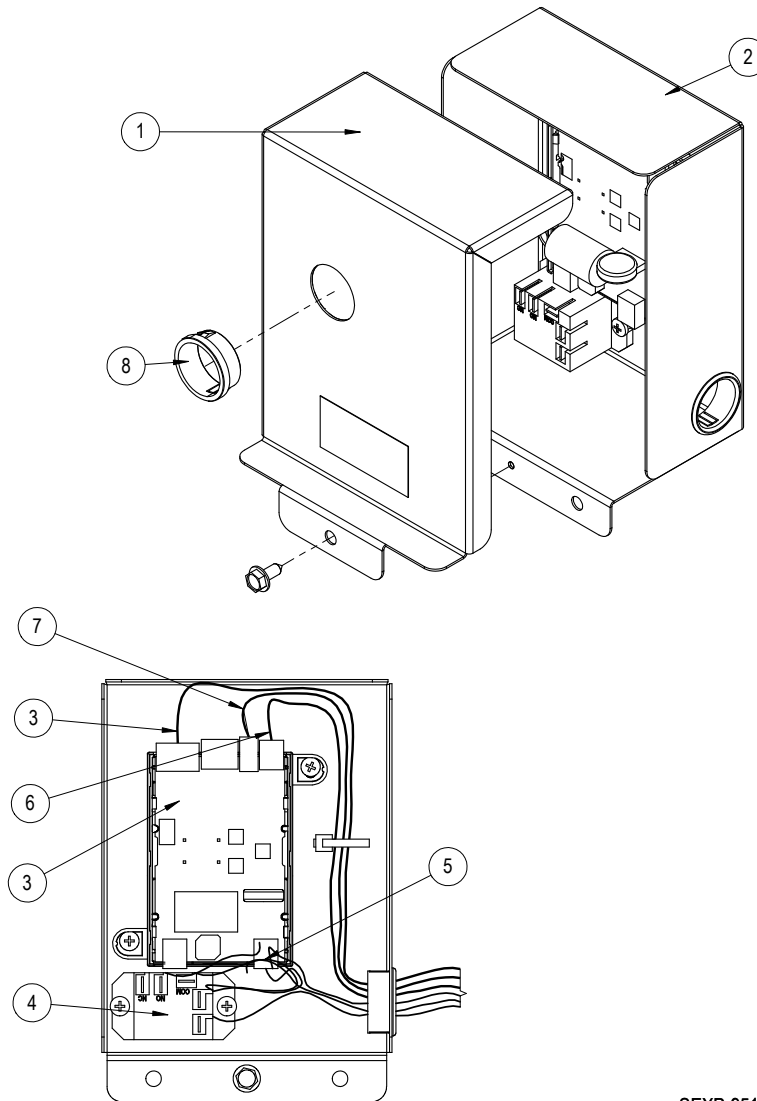

SEXP-951

910-2050-005BX

Dwg No.	Part Number	Description	
1	143-219BX	EEV Control Box Cover	X
2	127-572BX	EEV Control Box	X
3	8301-079-0005BX	EEV Control Module & Stator Cable	X
3	5651-246BX	EEV Stator Cable Only	X
4	8201-130BX	Control Relay	X
5	3000-1602BX	Main Wire Assembly	X
6	3000-1611BX	Transducer Wire Assembly – Connects to EEV Board	X
NS	3000-1603BX	Transducer Wire Assembly – Connects to Transducer	
7	8408-056BX	EEV Thermistor	X
8	8611-075	Clear Snap Plug	X