REPLACEMENT PARTS MANUAL

WALL MOUNTED PACKAGE HEAT PUMPS

**Models: WH303
WH363**

General Notes

- Revised and/or additional pages may be issued from time to time.
- A complete and current manual consists of pages shown in the following contents section.

Important

- Contact the installing and/or local Bard distributor for all parts requirements. Make sure you have the complete model and serial number available from the unit rating plate.

Contents

Description	Page
Cabinet Components	
♦ Exploded View	2
♦ Usage List	3
Functional Components	
♦ Exploded View	4
♦ Usage List	5
Control Panel	
♦ Layout View	6
♦ Usage List	7
Blower Housing	
♦ Exploded View	8
♦ Usage List	8



Bard Manufacturing Company, Inc.
Bryan, Ohio 43506
Since 1914...Moving ahead, just as planned.

Manual: 2110-565A
Supersedes: 2110-565
File: Tab 17
Date: 09-05-08

CABINET COMPONENTS

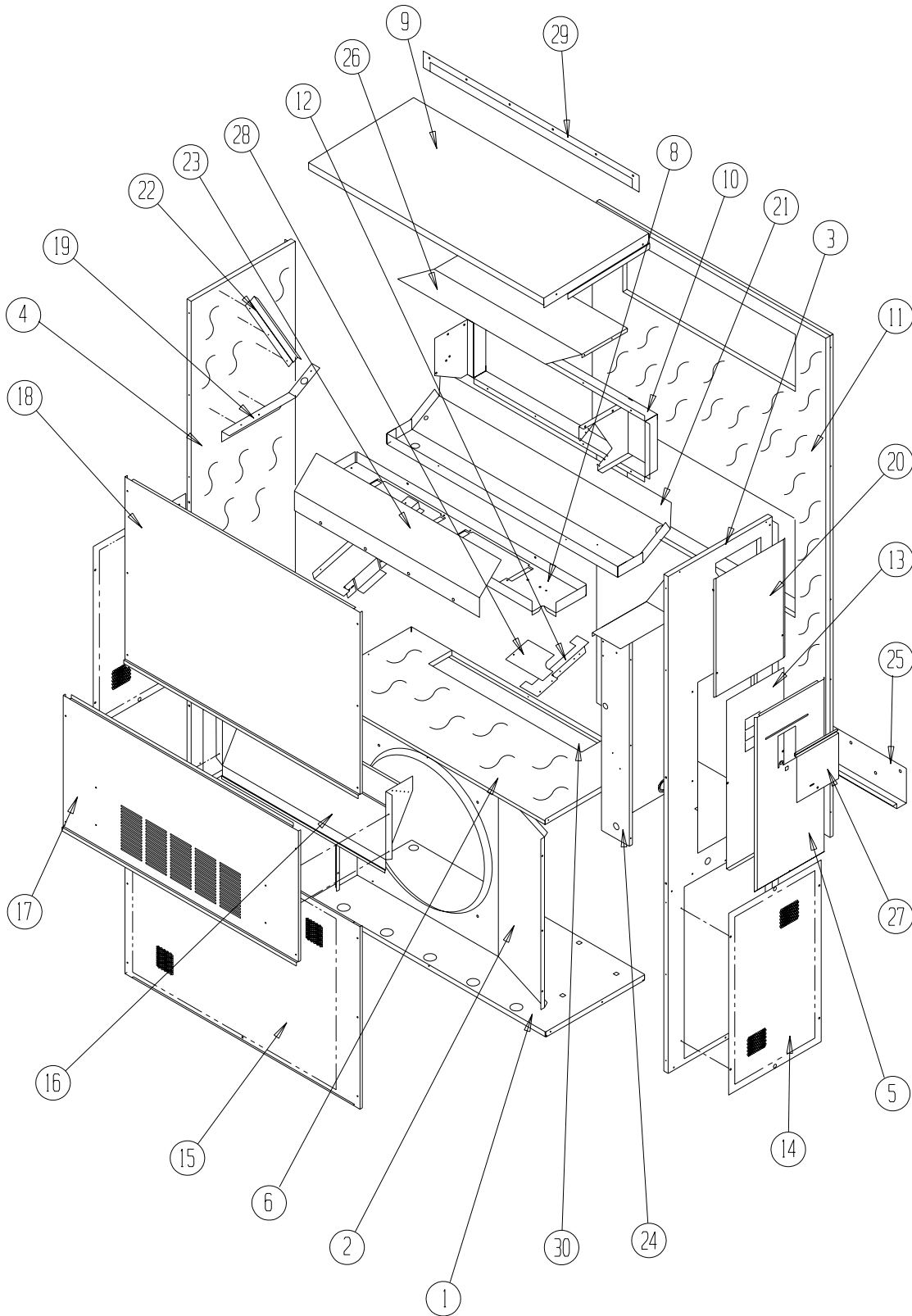

SEXP-160

CABINET COMPONENTS

Drawing No.	Part No.	Description	WH303-A,-B	WH303-C	WH363-A,-B	WH363-C
1	S127-199	Lower Base	X	X	X	X
2	125-022	Fan Shroud	X	X	X	X
3	S500-228-* ①	Right Side	X	X	X	X
4	S500-229-* ①	Left Side	X	X	X	X
5	S533-109-* ①	Control Panel Cover (Outer)	X	X	X	X
6	S521X384	Condenser Partition	X	X	X	X
8	121X182	Blower Partition	X	X	X	X
9	S506-130-* ①	Top	X	X	X	X
10	S111X030	Outlet Air Frame Assembly	X	X	X	X
11	S508-088	Back	X	X	X	X
12	113X195	Filter Bracket	2	2	2	2
13	S132-104	Control Panel Cover (Inner)	X		X	
13	S132-172	Control Panel Cover (Inner)		X		X
14	118-056-* ①	Side Grille	2	2	2	2
15	118-059-* ①	Condenser Grille	X	X	X	X
16	BFAD-3	Fresh Air Damper Assembly	X	X	X	X
17	S552-206-* ①	Service Door	X	X	X	X
18	S514-072-* ①	Upper Front	X	X	X	X
19	105X850	Left Side Support	X	X	X	X
20	S143-034-* ①	Right Side Cover Plate (Outer)	X	X	X	X
21	S123-078	Drain Pan	X	X	X	X
22	147-044	Left Evaporator Support	X	X	X	X
23	135-214	Air Baffle	X	X	X	X
24	Control Panel Assembly	See Control Panel Assembly Drawing and Parts List Assembly	X	X	X	X
25	113-140	Bottom Mounting Bracket	1	1	1	1
26	135X123	Heat Shield	X	X	X	X
27	S153-218-* ①	Disconnect Access Door	X	X	X	X
28	137-259	Fill Plate	X	X	X	X
29	113-149-* ①	Top Rain Flashing	X	X	X	X
30	S536-498	Cond. Part. Block Off Plate	X	X	X	X

① Exterior cabinet parts are manufactured with various paint color options. To insure that you receive the proper paint color, you must include the complete model and serial number of the unit for which cabinet parts are being ordered.

FUNCTIONAL COMPONENTS

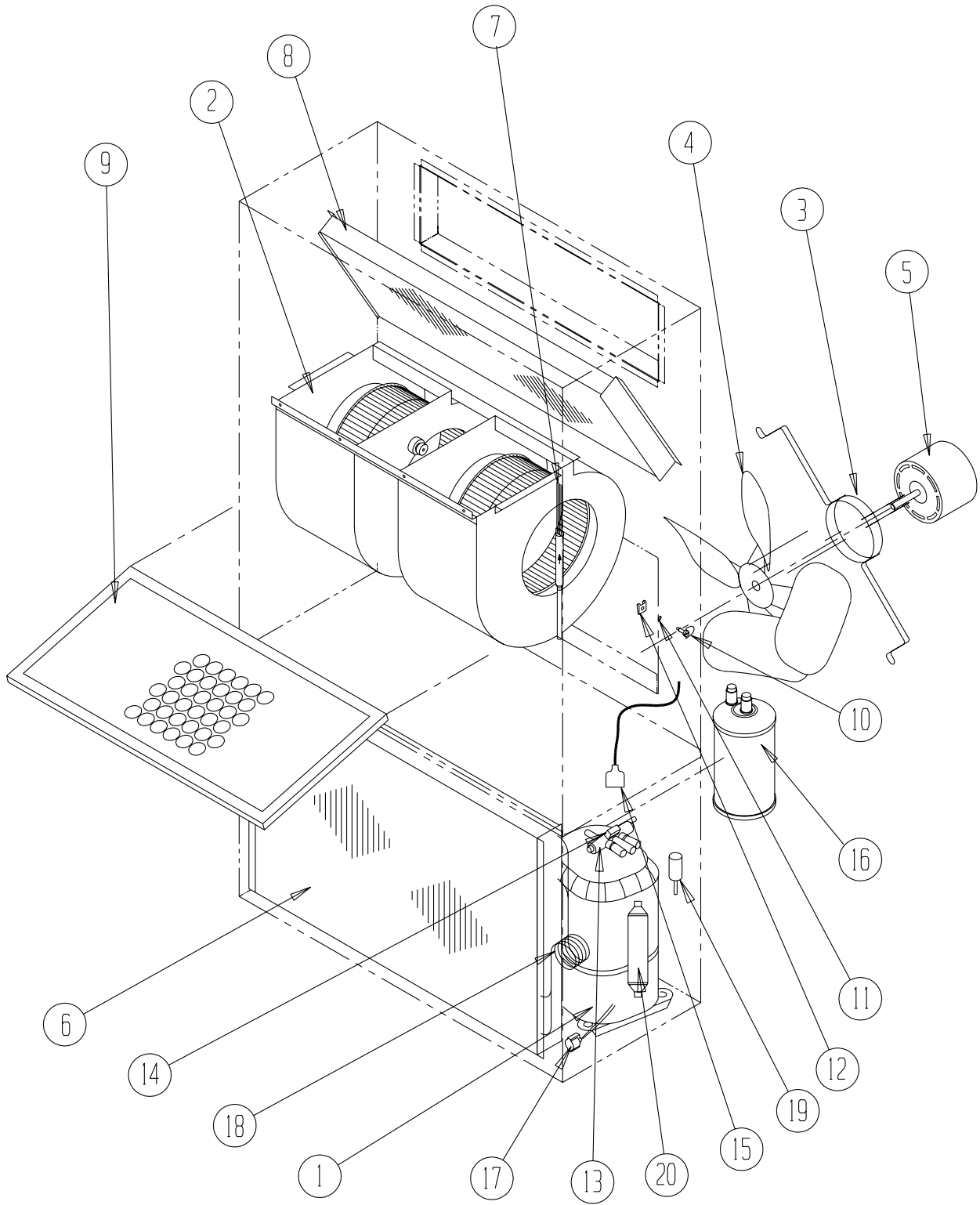

SEXP-503

FUNCTIONAL COMPONENTS

Drawing No.	Part No.	Description	WH303-A	WH303-B	WH303-C	WH363-A	WH363-B	WH363-C
1	8000-291 	Compressor				X		
1	8000-295	Compressor	X					
1	8000-296	Compressor					X	
1	8000-297	Compressor						X
1	8000-302	Compressor		X				
1	8000-303	Compressor			X			
2	S900-231	Blower Assembly	X	X		X	X	
2	S900-232	Blower Assembly			X			X
3	8200-001	Fan Motor Mount	X	X	X	X	X	X
4	5151-045	Fan Blade	X	X	X	X	X	X
5	8103-013	Condenser Motor	X	X		X	X	
5	8103-020	Condenser Motor			X			X
6	5051-112BX	Condenser Coil				X	X	X
6	5051-067BX	Condenser Coil	X	X	X			
7	800-0189	Cooling Capillary Assembly	X	X	X	X	X	X
7	800-0357	Cooling Distributor Assembly	X	X	X			
8	5060-064BX	Evaporator Coil	X	X	X	X	X	X
9	7004-019	Air Filter 1" Throw Away	X	X	X	X	X	X
9	7003-031	Air Filter 1" Washable (Optional)	X	X	X	X	X	X
9	7004-026	Air Filter 2" Pleated (Optional)	X	X	X	X	X	X
10	1171-022	1/4" Turn Fastener	X	X	X	X	X	X
11	1171-024	1/4" Turn Retainer	X	X	X	X	X	X
12	1171-023	1/4" Receptacle	X	X	X	X	X	X
13	5650-039	Reversing Valve with 24V Solenoid Coil	X	X	X	X	X	X
14	5650-042	Rev. Valve Solenoid, Red Casing (Ranco)	X	X	X	X	X	X
14	5650-043	Rev. Valve Solenoid, Black Casing (Wilspec)	X	X	X	X	X	X
14	5650-046	Rev. Valve Solenoid, Black Casing (San Hua)	X	X	X	X	X	X
15	5650-037	Molded Plug 36" Lead	X	X	X	X	X	X
16	5202-022	Accumulator	X	X	X	X	X	X
17	8620-095	Defrost Sensor	X	X	X	X	X	X
18	800-0356	Heating Distributor Assembly				X	X	X
18	800-0186	Heating Capillary Assembly	X	X	X			
19	1804-0106	High Pressure Switch (Flare) (Optional)	X	X	X	X	X	X
20	5220-012	Muffler/Check Valve	X	X	X	X	X	X
NS	1804-0107	Low Pressure Switch (Flare) (Optional)	X	X	X	X	X	X
NS	CMA-6	Low Ambient Control (Flare) (Optional)	X	X	X	X	X	X
NS	5651S036	Check Valve	X	X	X			

NS = Not Shown

CONTROL PANEL COMPONENTS

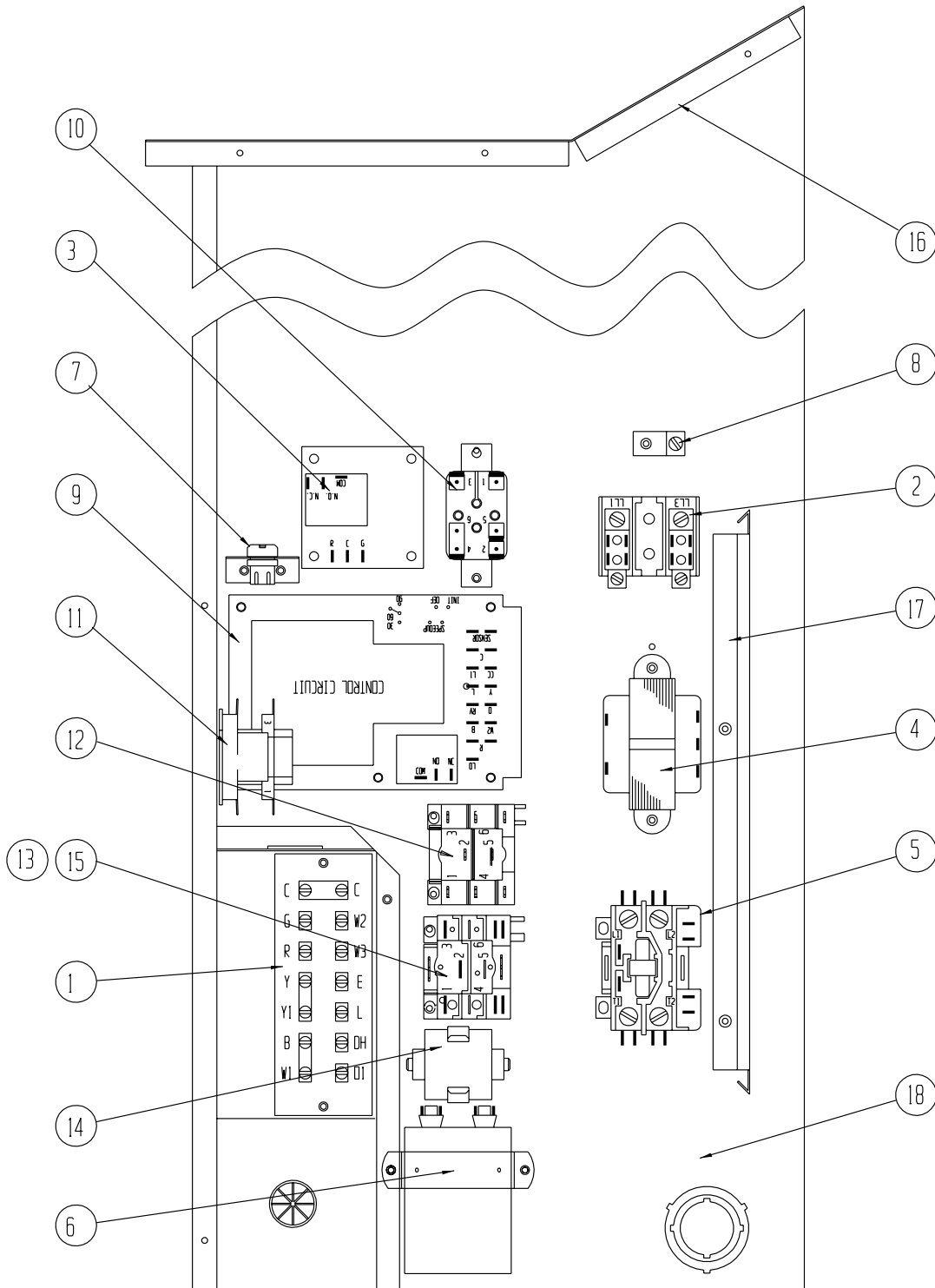

SEXP-168 A

CONTROL PANEL COMPONENTS

Drawing No.	Part No.	Description	WH303-A	WH303-B	WH303-C	WH363-A	WH363-B	WH363-C
1	8607-019	Low Voltage Terminal Strip	X	X	X	X	X	X
2	8607-013	Terminal Block 2 Pole	X			X		
2	8607-014	Terminal Block 3 Pole		X	X		X	X
2	8607-015	Phenolic Insulator			X			X
3	8201-056	Blower Control	X	X		X	X	
3	8201-032	Blower Relay			X			X
4	8407-035	Transformer	X	X		X	X	
4	8407-042	Transformer			X			X
5	8401-007	Compressor Contactor	X			X		
5	8401-002	Compressor Contactor		X	X		X	X
6	8552-050	Compressor Capacitor	X					
6	8552-048	Compressor Capacitor				X		
6	8552-002	Outdoor Motor Capacitor		X	X		X	X
7	3000-971	6 Pin Connector	X	X	X	X	X	X
8	8611-006	Ground Terminal	X	X	X	X	X	X
9	8201-102	Heat Pump Control Board	X	X	X	X	X	X
11	8201-065	Low Pressure Bypass TDR ①	X	X	X	X	X	X
12	8201-086	LAC Bypass Relay ①	X	X	X	X	X	X
13	8607-017	LAC Terminal Block ①	X	X	X	X	X	X
14	8551-004	Start Device ①	X			X		
15	8201-032	Outdoor Fan Relay			X			X
16	117X137	Control Panel Top	X	X	X	X	X	X
17	135-122	Wire Shield	X	X	X	X	X	X
18	117X232	Control Panel	X	X	X	X	X	X
NS	4096-110	Wiring Diagram	X			X		
NS	4096-210	Wiring Diagram		X			X	
NS	4096-310	Wiring Diagram			X			X

NS = Not Shown

① = Optional

BLOWER ASSEMBLY

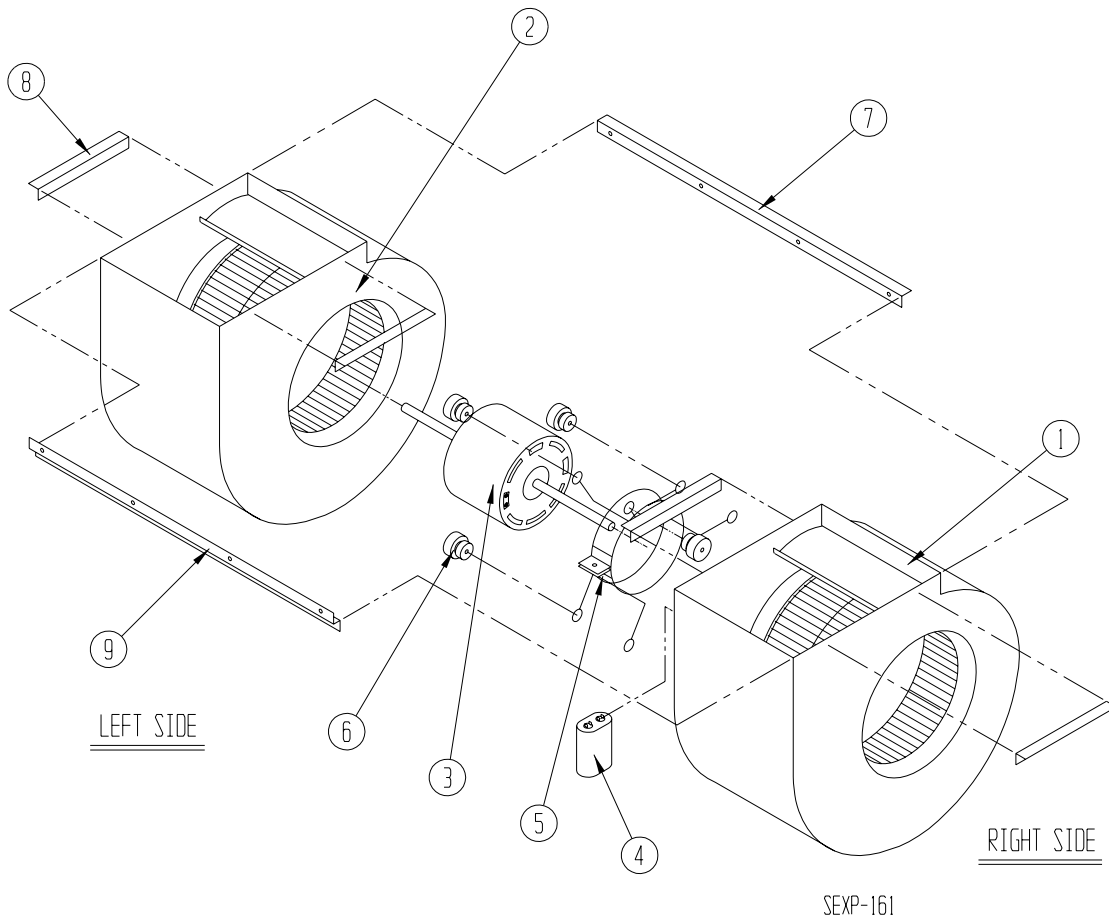

Drawing No.	Part No.	Description	S900-179	S900-180
1	151-111	Blower Housing	2	2
2	144-174	Diffuser	2	2
3	8105-029	Blower Motor (230/208)	X	
3	8105-033	Blower Motor (460)		X
4	8552-002	Capacitor	X	X
5	8200-031	Motor Mount	X	X
6	5451-011	Grommets	6	6
7	105-870	Back Brace	X	X
8	103-401	Front Brace	X	X
9	5152-090	Wheel CW	X	X
10	5152-091	Wheel CCW	X	X