

REPLACEMENT PARTS MANUAL

WALL MOUNT  
GAS ELECTRICS  
MODELS WAG30A, WAG36A, WAG40A

Manual 2110-801

Revision E

Date 5-04-92

Supersedes 8-30-91

\*\*\*\*\*  
\* GENERAL NOTES \*  
\*\*\*\*\*

\*Revised and/or additional pages may be issued from time to time.  
\*A complete and current manual consists of pages dated as shown in the following index.

\*\*\*\*\*  
\*\* INDEX \*\*  
\*\*\*\*\*

<u>Page Description</u>	<u>Page</u>	<u>Date</u>	<u>Supersedes</u>
Cabinet Components--Exploded View	1	Z-19-90	7-11-89
--Usage List	2	z-19-90	7-11-89
Functional Components--Exploded View	3	Z-19-90	1-25-90
"          "--Usage List	4	5-04-92	8-30-91
Control Panel--Layout View	5	7-11-89	
"          "--Usage List	6	7-11-89	

\*\*\*\*\*  
\*\*\* IMPORTANT \*\*\*  
\*\*\*\*\*

Contact the installing and/or local Bard distributor for all parts requirements. Make sure you have the complete model and serial number available from the unit rating plate.

CABINET COMPONENTS

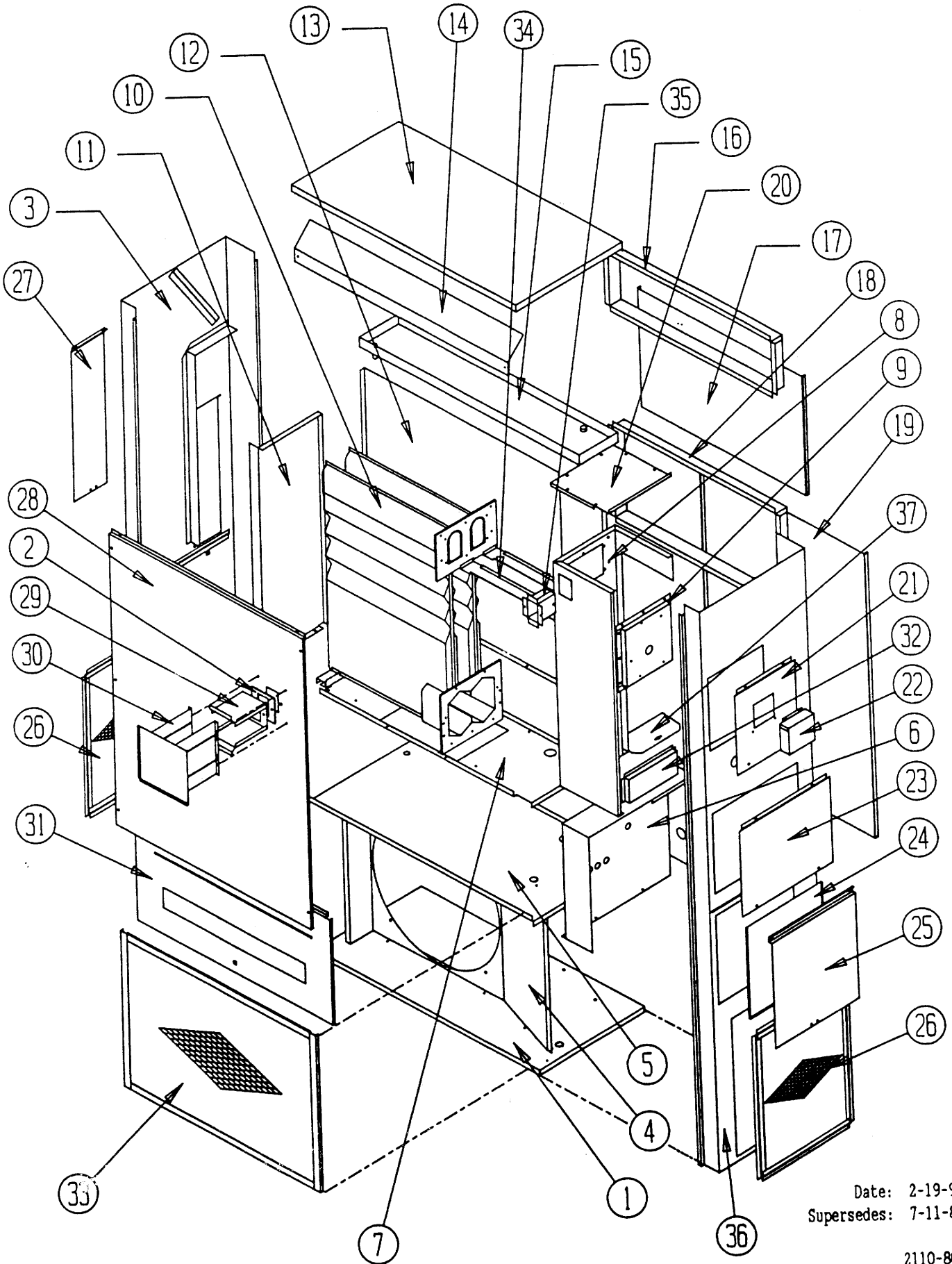

Date: 2-19-90  
Supersedes: 7-11-89

CABINET COMPONENTS

Dwg. No.	Part No.	Description	W	W	W	W	W	W	W
			A	A	A	A	A	A	A
			G	G	G	G	G	G	G
			3	3	3	3	4	4	4
			A	A	A	A	A	A	A
			A	A	B	C	A	B	C
			5	5	5	5	5	5	5
			4	4	4	4	4	4	4
			C	C	C	C	C	C	C
1	127-142	Lower Base	X	X	X	X	X	X	X
2	1921-017	Vent Term. Gasket	X	X	X	X	X	X	X
3	501-179	Left Side Assembly	X	X	X	X	X	X	X
4	124-016	Fan Shroud	X	X	X	X	X	X	X
5	520-108	Condenser Partition	X	X	X	X	X	X	X
6	Control Panel	(See Control Panel Assembly Drawing and Parts List)							
7	127-143	Blower Base	X	X	X	X	X	X	X
8	520-110	Heat Exchanger Partition	X	X	X	X	X	X	X
9	913-0018	Flue Collector Box Assembly	X	X	X	X	X	X	X
10	171-152	Heat Exchanger Assembly	X	X	X	X	X	X	X
11	520-111	Side Partition Assembly	X	X	X	X	X	X	X
12	520-109	Vertical Partition	X	X	X	X	X	X	X
13	506-107	Top	X	X	X	X	X	X	X
14	134-096	Air Baffle	X	X	X	X	X	X	X
15	123-067	Water Pan Assembly	X	X	X	X	X	X	X
16	111-025	Outlet Air Frame	X	X	X	X	X	X	X
17	508-056	Upper Back	X	X	X	X	X	X	X
18	111-018	Inlet Air Frame	X	X	X	X	X	X	X
19	508-069	Lower Back Assembly	X	X	X	X	X	X	X
20	506-108	Heat Exchanger Part. Top	X	X	X	X	X	X	X
21	552-138	Induced Blower Door	X	X	X	X	X	X	X
22	134-097	Induced Blower Hood	X	X	X	X	X	X	X
23	152-139	Burner Door	X	X	X	X	X	X	X
24	132-096	Inner Control Cover	X	X	X		X	X	
24	132-078	Inner Control Cover				X			X
25	152-136	Outer Control Cover	X	X	X	X	X	X	X
26	119-020	Side Condenser Grille	2	2	2	2	2	2	2
27	552-137	Filter Access	X	X	X	X	X	X	X
28	514-062	Upper Front	X	X	X	X	X	X	X
29	168-029	Inner Vent Term	X	X	X	X	X	X	X
30	169-030	Outer Vent Term	X	X	X	X	X	X	X
31	514-063	Lower Front	X	X	X	X	X	X	X
32	168-003	Secondary Air Baffle	X	X	X	X	X	X	X
33	119-003	Front Condenser Grille	X	X	X	X	X	X	X
34	168-002	Flue Baffle	2	2	2	2	2	2	2
35	169-026	Flue Transition	X	X	X	X	X	X	X
36	501-178	Right Side Assembly	X	X	X	X	X	X	X
37	140-164	Switch Support	X	X	X	X	X	X	X

Date: 2-19-90  
Supersedes: 7-11-89

2110-801

FUNCTIONAL COMPONENTS

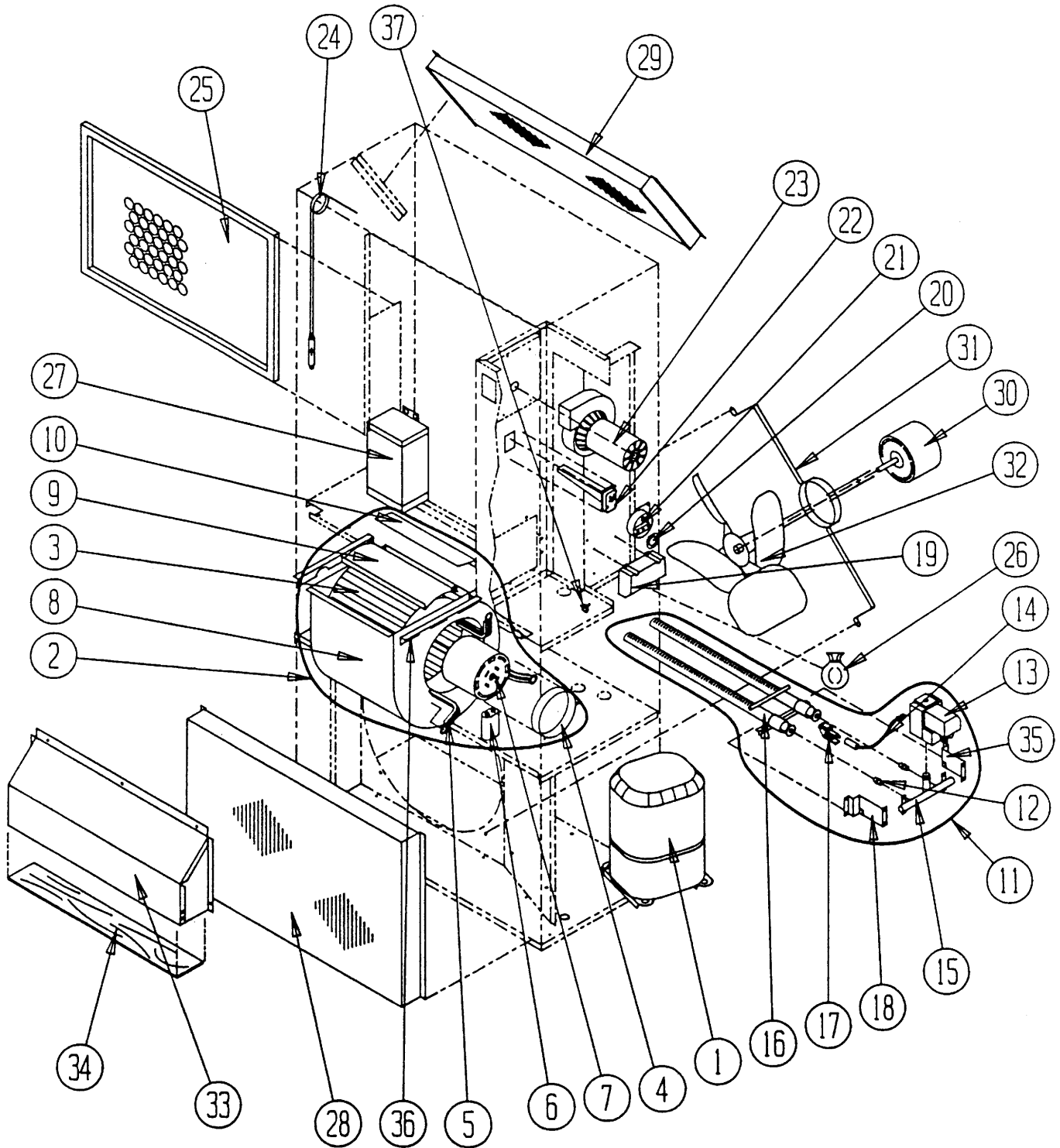

Date: 2-19-90  
Supersedes: 1-25-90

FUNCTIONAL COMPONENTS

Dwg. No.	Part No.	Description	W	W	W	W	W	W	W
			A	A	A	A	A	A	A
			G	G	G	G	G	G	G
			3	3	3	3	4	4	4
			A	A	A	A	A	A	A
			A	A	B	C	A	B	C
			5	5	5	5	5	5	5
			4	4	4	4	4	4	4
			C	C	C	C	C	C	C
1	8000-099	Compressor	X						
1	8000-055	Compressor		X					
1	8000-056	Compressor			X				
1	8000-057	Compressor				X			
1	8000-063	Compressor					X		
1	8000-064	Compressor						X	
1	8000-065	Compressor							X
2	900-123	Blower Assembly (Complete)	X	X	X	X	X	X	X
3	5152-059	Blower Wheel	X	X	X	X	X	X	X
4	8200-033	Motor Mount Band	X	X	X	X	X	X	X
5	8200-036	Motor Mount Arm	3	3	3	3	3	3	3
6	8552-002	Capacitor	X	X	X	X	X	X	X
7	8105-031	Blower Motor	X	X	X	X	X	X	X
8	151-083	Blower Housing	X	X	X	X	X	X	X
9	144-129	Diffuser	X	X	X	X	X	X	X
10	104-752	Blower Seal	X	X	X	X	X	X	X
11	901-0072	Burner Assembly (Complete)	X	X	X	X	X	X	X
12	9010-043	High Rate Orifice (Nat. #36)	2	2	2	2	2	2	2
13	5651-065	Gas Valve <i>3951080</i>	X	X	X	X	X	X	X
14	8600-010	Ignition Wire	X	X	X	X	X	X	X
15	5818-023	Burner Manifold	X	X	X	X	X	X	X
16	9010-036	Burner (2 Cell)	X	X	X	X	X	X	X
17	8620-038	Pilot Burner <i>x</i>	X	X	X	X	X	X	X
18	112Y095	Left Manifold Bracket	2	2	2	2	2	2	2
19	5651-093	Ignition Module	X	X	X	X	X	X	X
20	5451-015	Rubber Grommet	X	X	X	X	X	X	X
21	8406-052	Pressure Switch	X	X	X	X	X	X	X
22	8402-052	Limit Control	X	X	X	X	X	X	X
23	8109-002	Induced Draft Motor	X	X	X	X	X	X	X
24	800-0128	Capillary Assembly	X						
24	800-0129	Capillary Assembly		X	X	X			
24	800-0130	Capillary Assembly					X	X	X
25	7004-016	Air Filter	X	X	X	X	X	X	X
26	400-0027	Low Rate Orifice Kit (Nat. #40)	X	X	X	X	X	X	X
27	8407-003	460V Transformer				X			X
28	5051-035	Condenser Coil	X						
28	5051-054	Condenser Coil		X	X	X	X	X	X
29	5060-037	Evaporator Coil	X						
29	5060-050	Evaporator Coil		X	X	X	X	X	X
30	8103-019	Condenser Motor	X						
30	8105-034	Condenser Motor		X	X	X	X	X	X
31	8200-037	Fan Motor Mount	X	X	X	X	X	X	X
32	5151-038	Fan Blade	X						
32	5151-028	Fan Blade		X	X	X	X	X	X
33	913-0020	Fresh Air Damper Assembly	X	X	X	X	X	X	X
34	7003-019	Air Filter	X	X	X	X	X	X	X
35	112X095	Right Manifold Bracket	X	X	X	X	X	X	X
36	104-791	Blower Angles	2	2	2	2	2	2	2
37	8406-046	Flame Rollout Switch	X	X	X	X	X	X	X

Date: 15-14-92  
Supersedes: 08-30-91



CONTROL PANEL

Dwg. No.	Part No.	Description	W	W	W	W	W	W	W
			A	A	A	A	A	A	A
			G	G	G	G	G	G	G
			3	3	3	3	4	4	4
			0	6	6	6	0	0	0
			A	A	A	A	A	A	A
			A	A	B	C	A	B	C
			5	5	5	5	5	5	5
			4	4	4	4	4	4	4
			C	C	C	C	C	C	C
1	8201-053	Blower Control	X	X	X	X	X	X	X
2	8401-007	Contacto <del>r</del>	X	X			X		
2	8401-002	Contacto <del>r</del>			X	X		X	X
3	8407-034	Transformer	X	X	X	X	X	X	X
4	8615-009	Circuit Breaker	X						
4	8615-014	Circuit Breaker		X					
4	8615-018	Circuit Breaker			X				
4	8615-023	Circuit Breaker				X			
4	8615-015	Circuit Breaker					X		
4	8615-019	Circuit Breaker						X	
4	8615-024	Circuit Breaker							X
5	8201-008	Outdoor Fan Relay				X			X
6	8552-002	Fan Capacitor	X						
6	8552-005	Fan Capacitor		X	X	X	X	X	X
7	8552-032	Compressor Capacitor	X						
7	8552-035	Compressor Capacitor		X					
7	8552-030	Compressor Capacitor					X		
8		Low Voltage Kit	<----Field Installed---->						
9		Compressor Anti Cycle Relay	<----Field Installed---->						
	4085-110	Wiring Diagram	X	X			X		
	4085-210	Wiring Diagram			X			X	
	4085-310	Wiring Diagram				X			X

Date: 7-11-89  
Supersedes: