



**THE WALL-MOUNT™ STEP CAPACITY AIR CONDITIONERS**  
*Integrated Part Load Value (IPLV) Efficiency Up To 15.3 BTU/WATT*

**WA3S – WA5S Right Side Control Panel**  
**WL3S – WL5S Left Side Control Panel**  
**3 to 5 Ton (35,400 to 56,500 Btuh) 60Hz**

**GREEN REFRIGERANT**  
**R-410A**



The Bard WAL “S” Series is the world’s most energy efficient wall mounted air conditioner featuring a multi-step capacity compressor with environmentally friendly non-ozone depleting refrigerant.

The Bard Wall-Mount Air Conditioner is a self contained energy efficient system, which is designed to offer maximum indoor comfort at a minimal cost without using valuable indoor floor space or outside ground space. This unit is the ideal product for versatile applications such as: new construction, modular offices, school modernization, telecommunication structures, portable structures or correctional facilities. Factory or field installed accessories are available to meet specific job requirements.

**Engineered Features**

**Multi-Capacity Two-Stage:**  
 Simple thermostatic control seamlessly stages the compressor and indoor airflow rate between high and low capacity operations without cycling the compressor. This helps to maximize comfort, humidity control, energy efficiency and overall reduction in compressor cycling for improved system life.

**Multi-Step Capacity Compressor:**  
 Copeland step-capacity scroll compressors are designed for increased efficiency, quieter operation and improved reliability for longer life.

**R-410A Refrigerant:**  
 Designed with R-410A (HFC) non-ozone depleting refrigerant in compliance with the Montreal protocol and 2010 EPA requirements.

**ECM Indoor Blower Motor:**  
 Features a variable speed motor providing super-high efficiency, low sound levels and soft-start capabilities. The motor is self-adjusting to provide the proper airflow rate for the staged capacity, and for higher static pressure in ducted installations without user adjustment or wiring changes.

**Aluminum Finned Copper Coils:**  
 Grooved tubing and enhanced louvered fin for maximum heat transfer and energy efficiency.

**Twin Blowers:**  
 Move air quietly. All models feature variable speed blower motors providing automatic airflow adjustment for high static or free blow (non-ducted) operation at a very low sound level. Motor overload protection is standard on all models.

**Foil Faced Insulation:**  
 Standard on all units.

**Start Kit:**  
 A PTCR compressor start assist (Positive Temperature Coefficient Resistor) is standard on all -A single-phase models to increase system reliability. This helps to insure compressor starts at adverse conditions by increasing the compressor starting torque.

**Compressor Control Module:**  
 Built-in off-delay timer adjustable from 30 seconds to 5 minutes. 2-minute on-delay if power interrupt. 120-second bypass for low pressure control, and both soft and manual lockouts for high and low pressure controls. Alarm output for alarm relay.

**Liquid Line Filter Drier:**  
 Standard on all units. Protects system against moisture.

**High & Low Pressure Switches are Auto-Reset:**  
 Standard on all units. Built-in lock-out circuit resets from the room thermostat. Provides commercial quality protection to the compressor.

**Crankcase Heaters:**  
 Factory installed crankcase heaters are standard on all models. This helps to insure ease of start at low temperatures and improves compressor life.

**Phase Rotation Monitor:**  
 Standard on all 3 phase scroll compressors. Protects against reverse rotation if power supply is not properly connected.

**Galvanized 20 Gauge Zinc Coated Steel Cabinet:**  
 Cleaned, rinsed, sealed and dried before the polyurethane primer is applied. The cabinet is handsomely finished with a baked on textured enamel, which allows it to withstand 1000 hours of salt spray tests per ASTM B117-03.

**Galvanized 16 Gauge Zinc Coated Unit Base:**  
 The unit base is treated with the same paint coatings as the cabinet above, insuring years of service without visible corrosion.

**Drain Pan:**  
 The evaporator drain pan is constructed of stainless steel material for maximum corrosion resistance.

**Electrical Components:**  
 Are easily accessible for routine inspection and maintenance through a right side, service panel opening. Features a lockable, hinged access cover to the circuit breaker or toggle disconnect switch.

**Electric Heat Strips:**  
 Features line break automatic limit and dual backup safety controls. Heater packages can be factory or field installed for all models.

**Filter Service Door:**  
 Separate service door provides easy access for filter change.

**Two-Inch, Pleated Disposable Air Filters:**  
 Are standard equipment.

**Condenser Fan and Motor Shroud Assembly:**  
 Slides out for easy access.

**Circuit Breakers/Rotary Disconnect:**  
 Standard on all versions of single (230/208 volt) and three phase (230/208 volt) equipment. Rotary disconnects are standard on all versions of three phase (460 volt) equipment.

**Slope Top:**  
 Standard feature for water run-off.

**Full Length Mounting Brackets:**  
 Built into cabinet for improved appearance and easy installation. NOTE: Bottom mounting bracket included to assist in installation.

**Top Rain Flashing:**  
 Standard feature on all models.

- Complies with efficiency requirements of ANSI/ASHRAE/IESNA 90.1-2010.
- Certified to ANSI/ARI Standard 390-2003 for SPVU (Single Package Vertical Units).
- Intertek ETL Listed to Standard for Safety Heating and Cooling Equipment ANSI/UL 1995/CSA 22.2 No. 236-05, Fourth Edition.
- Commercial Product - Not intended for Residential application.



## Capacity and Efficiency Ratings <sup>①</sup>

Models	WA3S3 WL3S2	WA4S3 WL4S2	WA5S3 WL5S2
Cooling Capacity BTUH, 2nd Stage Operation	35,200	45,500	56,500
EER 2nd Stage Operation <sup>①②</sup>	11.4	11.2	10.4
Rated CFM (Wet Coil)	1100	1500	1700
Cooling Capacity BTUH, 1st Stage Operation	24,400	34,000	40,000
EER 1st Stage Operation <sup>②</sup>	11.7	11.7	10.8
Rated CFM (Wet Coil)	800	1100	1300
IPLV <sup>③</sup>	15.1	15.3	14.1

① Certified in accordance with ANSI/ARI Standard 390-2003 for single package vertical units.

② EER = Energy Efficiency Ratio - BTU/WATT efficiency.

③ Integrated Part Load Value - BTU/WATT efficiency and certified in accordance with ANSI/ARI Standard 390-2003.

All capacity, efficiency and cost of operation information is based on operation with fresh air cover plate. Cover plate is recommended for use to obtain maximum energy efficiency where ventilation air is not required.

## Indoor Blower Performance - CFM (0.00" through 0.80" H<sub>2</sub>O) <sup>①</sup>

	Blower Only	1st Stage Cooling	2nd Stage Cooling	5-10 KW Electric Heat	15-20 KW Electric Heat
WA3S3 WL3S2	800	800	1100	1100	1400
WA4S3 WL4S2	825	1100	1500	1100	1500
WA5S3 WL5S2	850	1300	1700	1100	1500

① These systems contain Variable Speed ECM Motor, which maintains airflow across static range at dry and wet coil conditions.

## Specifications 3 Ton through 5 Ton

MODELS	WA3S3-A WL3S2-A	WA3S3-B WL3S2-B	WA3S3-C WL3S2-C	WA4S3-A WL4S2-A	WA4S3-B WL4S2-B	WA4S3-C WL4S2-C	WA5S3-A WL5S2-A	WA5S3-B WL5S2-B	WA5S3-C WL5S2-C
Cooling Capacity	35,400	35,400	35,400	46,000	46,000	46,000	56,500	56,500	56,500
Heating Capacity	See Electric Heat Table								
<b>Electrical Rating – 60 Hz</b>	230/208 - 1	230/208 - 3	460 - 3	230/208 - 1	230/208 - 3	460 - 3	230/208 - 1	230/208 - 3	460 - 3
Operating Voltage Range	197-253	197-253	414-506	197-253	197-253	414-506	197-253	197-253	414-506
<b>Compressor – Circuit A</b>									
Voltage	230/208	230/208	460	230/208	230/208	460	230/208	230/208	460
Rated Load Amps	12.3/14.6	6.7/7.9	3.6	16.1/19.1	10.1/12	4.8	21.9/26.6	15.5/18.9	7.8
Branch Circuit Selection Current	16.7	11.2	4.5	21.2	13.5	6.5	26.6	18.9	9.0
Lock Rotor Amps	82 / 82	58 / 58	30	96 / 96	88 / 88	41	118 / 118	123 / 123	62
Compressor Type	Scroll	Scroll	Scroll	Scroll	Scroll	Scroll	Scroll	Scroll	Scroll
<b>Fan Motor &amp; Condenser</b>									
Fan Motor--HP--RPM-SPD	1/3 - 825 - 2	1/3 - 825 - 2	1/3 - 825 - 1	1/3 - 825 - 2	1/3 - 825 - 2	1/3 - 825 - 1	1/3 - 825 - 2	1/3 - 825 - 2	1/3 - 825 - 1
Fan Motor--Amps	2.5	2.5	1.3	2.5	2.5	1.3	2.5	2.5	1.3
Fan--DIA/CFM	24" - 2700	24" - 2700	24" - 2700	24" - 2800	24" - 2800	24" - 2800	24" - 2800	24" - 2800	24" - 2800
<b>Blower Motor &amp; Evap.</b>									
Blower Motor--HP--RPM-SPD	1/2-Variable	1/2-Variable	1/2-Variable	3/4-Variable	3/4-Variable	3/4-Variable	3/4-Variable	3/4-Variable	3/4-Variable
Blower Motor--Amps	5.3	5.3	5.3	6.8	6.8	6.8	6.8	6.8	6.8
CFM Cooling & E.S.P.	1100	1100	1100	1500	1500	1500	1700	1700	1700
Filter Size	20 x 30 x 2	20 x 30 x 2	20 x 30 x 2	20 x 30 x 2	20 x 30 x 2	20 x 30 x 2	20 x 30 x 2	20 x 30 x 2	20 x 30 x 2
<b>Shipping Weight --LBS.</b>	530	530	530	530	530	530	530	530	530

## Ventilation System Packages

Bard Wall-Mounts are designed to provide optional ventilation packages to meet all of your ventilation and indoor air quality requirements. All units are equipped with a blank off plate as the standard ventilation package. All ventilation packages can be built-in at the factory, or field-installed at a later date.

### BLANK OFF PLATE - BOP

A blank off plate is installed on the inside of the service door. It covers the air inlet openings which restricts any outside air from entering the unit. The blank off plate should be utilized in applications where outside air is not required to be mixed with the conditioned air.

**STANDARD**

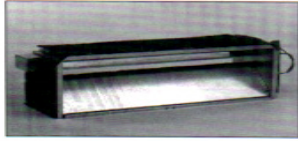

Motorized Fresh Air Damper

### MOTORIZED FRESH AIR DAMPER - MFAD

The motorized fresh air damper is internally mounted behind the service door and allows outside ventilation air, up to 25% of the total airflow rating of the unit, to be introduced through the air inlet openings and to be mixed with the conditioned air. The two position damper can be fully open or closed. The damper blade is powered open by a 24VAC motor with spring return on power loss. The damper can be controlled by indoor blower operation or can be field connected to be managed based on building occupancy.

**OPTIONAL**

**NOTE:** This vent system is intake only without built-in exhaust capability. Building will likely require separate field installed barometric relief or mechanical exhaust elsewhere within the conditioned space. Other building systems will govern actual amount of intake air.



COMMERCIAL ROOM VENTILATOR

### COMMERCIAL ROOM VENTILATOR - CRVMP

The built-in commercial room ventilator is internally mounted behind the service door and allows outside ventilation air, up to 50% of the total airflow rating of the unit, to be introduced through the air inlet openings. It includes a built-in exhaust air damper with integral bug screen. Automatic control is integrated to maintain desired ventilation air at the various supply airflows.

**OPTIONAL**

The commercial room ventilator (CRV) is a simple and innovative approach to improving the indoor air quality by providing fresh air intake and exhaust capability through the CRV. The damper can be easily adjusted to control the amount of fresh air supplied into the building. The CRV can be controlled by indoor blower operation or field controlled based on room occupancy. The CRV is power open - spring return on power loss. Complies with ANSI/ASHRAE Standard 62.1 "Ventilation for Acceptable Indoor Air Quality."



Economizer

### ECONOMIZER - ECONWMM-Series

The built-in economizer system is internally mounted behind the service door and allows outdoor air to be introduced through the air inlet openings. The amount of outdoor air varies in response to the system controls and settings defined by the end user. It includes a built-in exhaust air damper. The economizer is designed to provide "free cooling" when outside air conditions are cool and dry enough to satisfy cooling requirements without running the compressor. This in turn provides lower operating costs, while extending the life of the compressor.

**OPTIONAL**

- ECONWMT Equipment Building versions have extended 11" air intake hood to deliver up to 100% of cooling rated airflow.
- ECONWMS Standard versions have 3" air intake hood to deliver up to 75% of cooling rated airflow.

#### Standard Features:

- Fully modulating
- Honeywell Direct Drive Hi-Torque Actuator
- No linkage required
- Simple single blade design
- Positive shut-off with non-stick gaskets
- Electronic DB and/or Enthalpy sensors depending upon version
- Honeywell JADE electronic economizer module with precision settings and diagnostics
- DB or Enthalpy economizer versions available

### WALL-MOUNT ENERGY RECOVERY VENTILATOR - ERVF

The wall-mount energy recovery ventilator (ERV) is a highly innovative approach to meeting indoor air quality ventilation requirements as established by ANSI/ASHRAE Standard 62.1. The ERV allows from 200 to 450 CFM (depending upon model) of fresh air and exhaust through the unit while maintaining superior indoor comfort and humidity levels. In most cases this can be accomplished without increasing equipment sizing or operating costs. Heat transfer efficiency is up to 67% during summer and 75% during winter conditions.

**OPTIONAL**

The ERV consists of a unique "rotary energy recovery cassette" that provides effective sensible and latent heat transfer capabilities during summer and winter conditions. Various control schemes are addressed including limiting ventilation during building occupancy only.



ENERGY RECOVERY VENTILATOR

The ERV is designed to be internally mounted behind the service door in the WA/LS model wall-mount units. It can be built-in at the factory or field installed as an option. ERVF-\*5 can be independently adjusted for intake and exhaust rates.

**CRVMP-5  
WA3S/WL3S Ventilation Airflow**

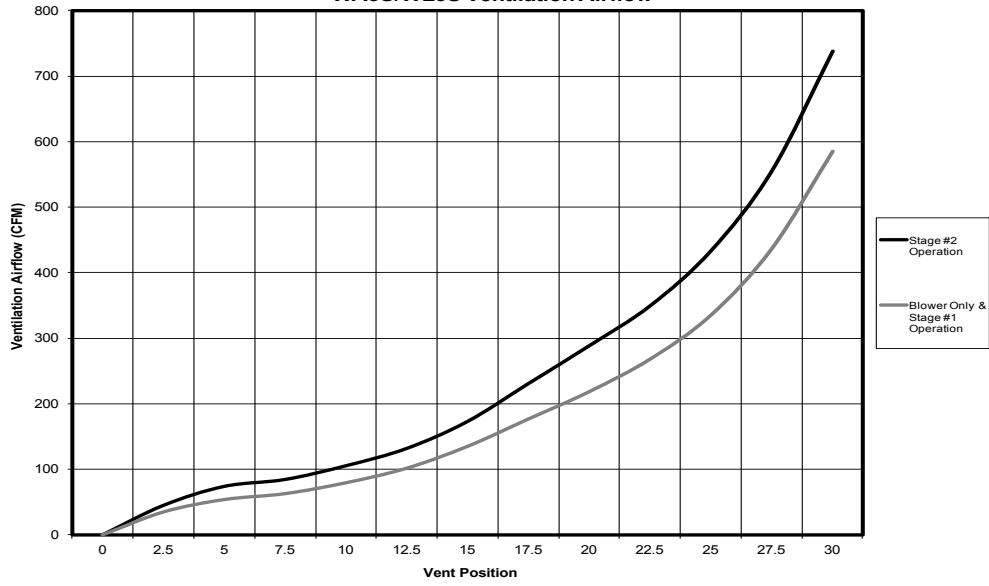

**CRVMP-5  
WA4S/WL4S Ventilation Airflow**

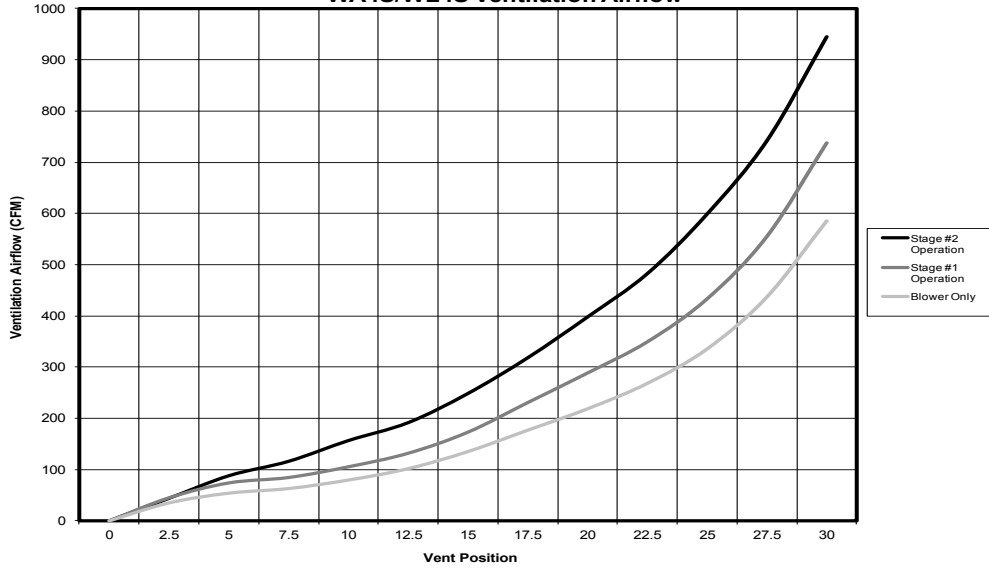

**CRVMP-5  
WA5S/WL5S Ventilation Airflow**

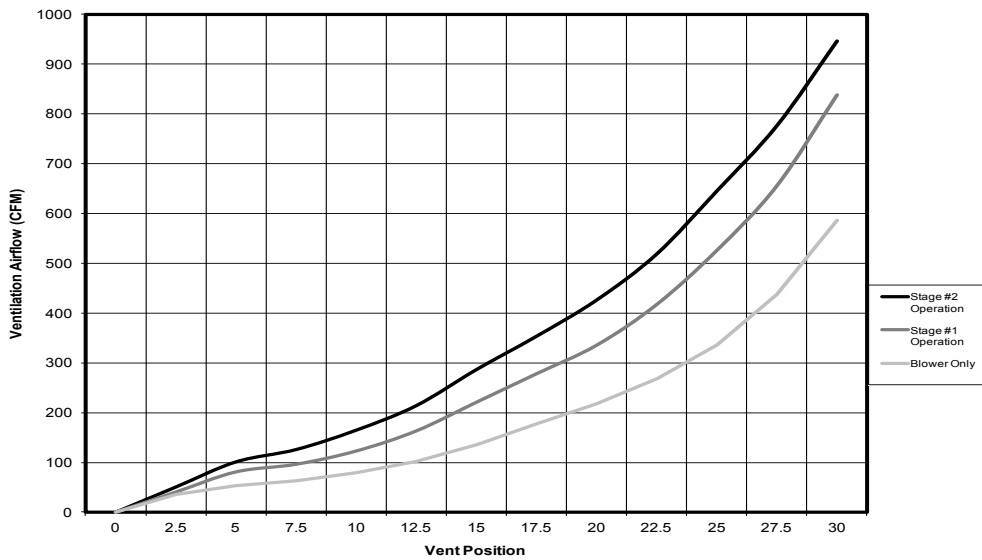

# Performance and Application Data- WERV-\*5

## SUMMER COOLING PERFORMANCE (INDOOR DESIGN CONDITIONS 75°DB/62°WB)

Ambient O.D.		VENTILATION RATE -- 450 CFM						VENTILATION RATE -- 375 CFM						VENTILATION RATE -- 300 CFM					
DB/ WB	F	VLT	VLS	VLL	HRT	HRS	HRL	VLT	VLS	VLL	HRT	HRS	HRL	VLT	VLS	VLL	HRT	HRS	HRL
105	75	21465	14580	6884	13952	9477	4475	17887	12150	5737	11805	8018	3786	14310	9720	4590	9587	6512	3075
	70	14580	14580	0	9477	9477	0	12150	12150	0	8018	8018	0	9720	9720	0	6512	6512	0
	65	14580	14580	0	9477	9477	0	12150	12150	0	8018	8018	0	9720	9720	0	6512	6512	0
100	80	31590	12150	19440	20533	7897	12635	26325	10125	16200	17374	6682	10692	21060	8100	12960	14110	5427	8683
	75	21465	12150	9314	13952	7897	6054	17887	10125	7762	11805	6682	5123	14310	8100	6210	9587	5427	4160
	70	12352	12150	202	8029	7897	131	10293	10125	168	6793	6682	111	8235	8100	135	5517	5427	90
	65	12150	12150	0	7897	7897	0	10125	10125	0	6682	6682	0	8100	8100	0	5427	5427	0
95	80	31590	9720	21870	20533	6318	14215	26325	8100	18225	17374	5345	12028	21060	6480	14580	14110	4341	9768
	75	21465	9720	11744	13952	6318	7634	17887	8100	9787	11805	5345	6459	14310	6480	7830	9587	4341	5246
	70	12352	9720	2632	8029	6318	1711	10293	8100	2193	6793	5345	1447	8235	6480	1755	5517	4341	1175
	65	9720	9720	0	6318	6318	0	8100	8100	0	5345	5345	0	6480	6480	0	4341	4341	0
90	80	31590	7290	24300	20533	4738	15794	26325	6075	20250	17374	4009	13365	21060	4860	16200	14110	3256	10854
	75	21465	7290	14175	13952	4738	9213	17887	6075	11812	11805	4009	7796	14310	4860	9450	9587	3256	6331
	70	12352	7290	5062	8029	4738	3290	10293	6075	4218	6793	4009	2784	8235	4860	3375	5517	3256	2261
	65	7290	7290	0	4738	4738	0	6075	6075	0	4009	4009	0	4860	4860	0	3256	3256	0
85	80	31590	4860	26730	20533	3159	17374	26325	4050	22275	17374	2672	14701	21060	3240	17820	14110	2170	11939
	75	21465	4860	16605	13952	3159	10793	17887	4050	13837	11805	2672	9132	14310	3240	11070	9587	2170	7416
	70	12352	4860	7492	8029	3159	4870	10293	4050	6243	6793	2672	4120	8235	3240	4995	5517	2170	3346
	65	4860	4860	0	3159	3159	0	4050	4050	0	2672	2672	0	3240	3240	0	2170	2170	0
80	75	21465	2430	19035	13952	1579	12372	17887	2025	15862	11805	1336	10469	14310	1620	12690	9587	1085	8502
	70	12352	2430	9922	8029	1579	6449	10293	2025	8268	6793	1336	5457	8235	1620	6615	5517	1085	4432
	65	4252	2430	1822	2764	1579	1184	3543	2025	1518	2338	1336	1002	2835	1620	1215	1899	1085	814
	60	2430	2430	0	1579	1579	0	2025	2025	0	1336	1336	0	1620	1620	0	1085	1085	0
75	70	12352	0	12352	8029	0	8029	10293	0	10293	6793	0	6793	8235	0	8235	5517	0	5517
	65	4252	0	4252	2764	0	2764	3543	0	3543	2338	0	2338	2835	0	2835	1899	0	1899
	60	0	0	0	0	0	0	0	0	0	0	0	0	0	0	0	0	0	0

## WERV-\*5 WINTER HEATING PERFORMANCE (INDOOR DESIGN CONDITIONS 70°F DB)

Ambient O.D.	VENTILATION RATE					
	450 CFM		375 CFM		300 CFM	
DB/°F	WVL	WHR	WVL	WHR	WVL	WHR
65	2430	1944	2025	1640	1620	1328
60	4860	3888	4050	3280	3240	2656
55	7290	5832	6075	4920	4860	3985
50	9720	7776	8100	6561	6480	5313
45	12150	9720	10125	8201	8100	6642
40	14580	11664	12150	9841	9720	7970
35	17010	13608	14175	11481	11340	9298
30	19440	15552	16200	13122	12960	10627
25	21870	17496	18225	14762	14580	11955
20	24300	19440	20250	16402	16200	13284
15	26730	21384	22275	18042	17820	14612

LEGEND:

VLT = Ventilation Load - Total  
VLS = Ventilation Load - Sensible  
VLL = Ventilation Load - Latent  
HRT = Heat Recovery - Total  
HRS = Heat Recovery - Sensible  
HRL = Heat Recovery - Latent  
WVL = Winter Ventilation Load  
WHR = Winter Heat Recovery

NOTE: Sensible performance only is shown for winter application.

# Electrical Specifications

MODEL	Rated Volts & Phase	No. Field Power Circuits	Single Circuit			Multiple Circuit														
			③ Minimum Circuit Ampacity	① Maximum External Fuse or Ckt. Brkr.	④ Field Power Wire Size	② Ground Wire	③ Minimum Circuit Ampacity			① Maximum External Fuse or Ckt. Breaker			② Field Power Wire Size							
							Ckt. A	Ckt. B	Ckt. C	Ckt. A	Ckt. B	Ckt. C	Ckt. A	Ckt. B	Ckt. C					
-A0Z		1	31	45	8	10														
-A05		1	35	45	8	10														
WA3S3	230/208-1	1	51	60	6	10														
WL3S2		1 or 2	61	70	6	8														
-A15		1 or 2	87	90	3	8														
-A20		1 or 3	113	115	2	6														
-B0Z		1	25	30	10	10														
WA3S3	230/208-1	1	27	30	10	10														
WL3S2		1	36	40	8	10														
-B15		1	55	60	6	10														
-C0Z		1	13	15	14	14														
WA3S3	460-3	1	14	15	14	14														
WL3S2		1	19	20	12	12														
-C15		1	28	30	10	10														
-A0Z		1	38	45	8	10														
-A05		1	38	45	8	10														
WA4S3	230/208-1	1	53	60	6	10														
WL4S2		1 or 2	63	70	6	8														
-A15		1 or 2	89	90	3	8														
-A20		1 or 3	115	120	2	6														
-B0Z		1	29	40	10	10														
WA4S3	230/208-3	1	29	40	10	10														
WL4S2		1	38	40	8	10														
-B15		1	56	60	6	10														
-C0Z		1	15	20	12	12														
WA4S3	460-3	1	16	20	12	12														
WL4S2		1	21	25	10	10														
-C15		1	30	30	10	10														
-A0Z		1	44	50	8	10														
-A05		1	44	50	8	10														
WA5S3	230/208-1	1	53	60	6	10														
WL5S2		1 or 2	63	70	6	8														
-A15		1 or 2	89	90	3	8														
-A20		1 or 3	115	120	2	6														
-B0Z		1	34	40	8	10														
WA5S3	230/208-3	1	34	40	8	10														
WL5S2		1	38	40	8	10														
-B15		1	56	60	6	10														
-C0Z		1	17	25	10	10														
WA5S3	460-3	1	17	25	10	10														
WL5S2		1	21	25	10	10														
-C15		1	30	30	10	10														

① Maximum size of the time delay fuse or HACR type circuit breaker for protection of field wiring conductors.

② Based on 75C copper wire. All wiring must conform to the National Electrical Code and all local codes.

③ These "Minimum Circuit Ampacity" values are to be used for sizing the field power conductors. Refer to the National Electrical code (latest version), Article 310 for power conductor sizing.

**Caution:** When more than one field power circuit is run through one conduit, the conductors must be derated. Pay special attention to note 8 of Table 310 regarding Ampacity Adjustment Factors when more than three (3) current carrying conductors are in a raceway.

\* Top outlet supply option is available only factory installed and only on the selected models.

**IMPORTANT:** While this electrical data is presented as a guide, it is important to electrically connect properly sized fuses and conductor wires in accordance with the National Electrical Code and all local codes.

## Electric Heat Table

Nominal KW	At 240V (1)				At 208V (1)				At 480V (2)			At 460V (2)		
	Kw	1-Ph Amps	3-Ph Amps	Btuh	Kw	1-Ph Amps	3-Ph Amps	Btuh	Kw	3-Ph Amps	Btuh	Kw	3-Ph Amps	Btuh
5.0	5.0	20.8		17,065	3.75	18.0		12,799						
6.0	6.0		14.4	20,478	4.50		12.5	15,359	6.0	7.2	20,478	5.52	6.9	18,840
8.0	8.0	33.3		27,304	6.00	28.8		20,478						
9.0	9.0		21.7	30,717	6.75		18.7	23,038	9.0	10.8	30,717	8.28	10.4	28,260
10.0	10.0	41.7		34,130	7.50	36.1		25,598						
15.0	15.0	62.5	36.1	51,195	11.25	54.1	31.2	38,396	15.0	18.0	51,195	13.80	17.3	47,099
20.0	20.0	83.3		68,260	15.00	72.1		51,195						

(1) These electric heaters are available in 230/208V units only.

(2) These electric heaters are available in 480V units only.

## Heater Packages - Field Installed WA3, WA4 & WA5S

- Designed for adding Electric Heat to 0 KW Units
- ETL US & Canada Listed
- Circuit Breaker Standard on 230/208V Models
- Toggle Disconnect Standard on 460V Models

Air Conditioner Models	-A00 Models 230/208-1		-B00 Models 230/208-3		-C00 Models 460-3	
	Heater Model #	KW	Heater Model #	KW	Heater Model #	KW
WA3S3	EHWA4S-A05B	5	EHWA3S-B06B EHWA5S-B09B EHWA5S-B15B	6 9 15	EHWA5S-C06 EHWA5S-C09 EHWA5S-C15	6 9 15
	EHWA5S-A08B	8				
	EHWA4S-A10B	10				
	EHWA4S-A15B	15				
	EHWA4S-A20B	20				
WA4S3	EHWA4S-A05B	5	EHWA5S-B06B EHWA5S-B09B EHWA5S-B15B	6 9 15	EHWA5S-C06 EHWA5S-C09 EHWA5S-C15	6 9 15
	EHWA5S-A08B	8				
	EHWA4S-A10B	10				
	EHWA4S-A15B	15				
	EHWA4S-A20B	20				
WA5S3	EHWA5S-A05B	5	EHWA5S-B06B EHWA5S-B09B EHWA5S-B15B	6 9 15	EHWA5S-C06 EHWA5S-C09 EHWA5S-C15	6 9 15
	EHWA5S-A08B	8				
	EHWA5S-A10B	10				
	EHWA5S-A15B	15				
	EHWA5S-A20B	20				

## Heater Packages - Field Installed WL3, WL4 & WL5S

- Designed for adding Electric Heat to 0 KW Units
- ETL US & Canada Listed
- Circuit Breaker Standard on 230/208V Models
- Toggle Disconnect Standard on 460V Models

Air Conditioner Models	-A00 Models 230/208-1		-B00 Models 230/208-3		-C00 Models 460-3	
	Heater Model #	KW	Heater Model #	KW	Heater Model #	KW
WL3S2	EHWA4S-A05LB	5	EHWA3S-B06LB EHWA5S-B09LB EHWA5S-B15LB	6 9 15	EHWA5S-C06L EHWA5S-C09L EHWA5S-C15L	6 9 15
	EHWA5S-A08LB	8				
	EHWA4S-A10LB	10				
	EHWA4S-A15LB	15				
	EHWA4S-A20LB	20				
WL4S2	EHWA4S-A05LB	5	EHWA5S-B06LB EHWA5S-B09LB EHWA5S-B15LB	6 9 15	EHWA5S-C06L EHWA5S-C09L EHWA5S-C15L	6 9 15
	EHWA5S-A08LB	8				
	EHWA4S-A10LB	10				
	EHWA4S-A15LB	15				
	EHWA4S-A20LB	20				
WL5S2	EHWA5S-A05LB	5	EHWA5S-B06LB EHWA5S-B09LB EHWA5S-B15LB	6 9 15	EHWA5S-C06L EHWA5S-C09L EHWA5S-C15L	6 9 15
	EHWA5S-A08LB	8				
	EHWA5S-A10LB	10				
	EHWA5S-A15LB	15				
	EHWA5S-A20LB	20				

**Return Air Acoustical Plenum  
WAPR11**

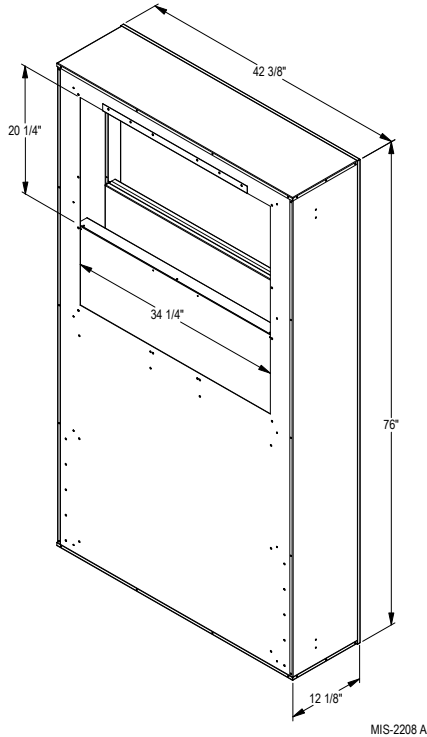

MIS-2208 A

**Free Blow Acoustical Plenum  
WAPFB51**

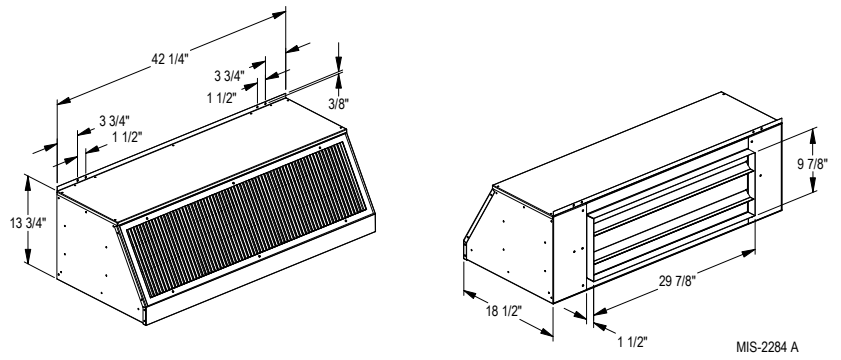

MIS-2284 A

<b>Optional Installation Accessories</b>			
<b>Description</b>	<b>Model</b>	<b>Color</b>	<b>Shipping Weight (Lbs.)</b>
Return Air Acoustical Plenum	WAPR11-X WAPR11-4	Beige Buckeye Gray	218
Ducted Supply Air Acoustical Plenum	WAPS51-G	Galvanized	190
Free Blow Supply Air Acoustical Plenum	WAPFB51-X WAPFB51-4	Beige Buckeye Gray	64

**Supply Air Acoustical Plenum  
WAPS51-G**

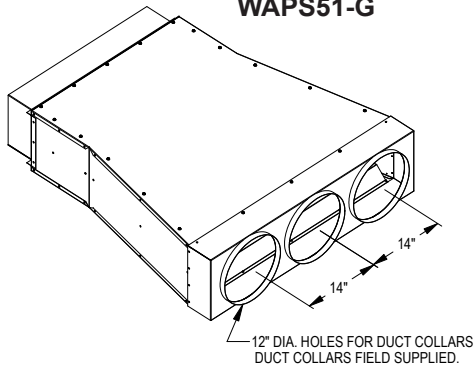

12" DIA. HOLES FOR DUCT COLLARS.  
DUCT COLLARS FIELD SUPPLIED.

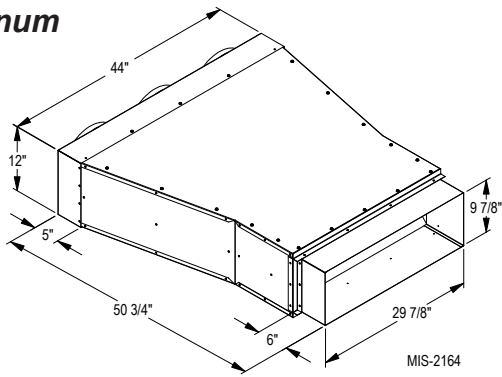

MIS-2164

**Typical installation with isolation curb, free blow, supply air acoustical plenum & return air acoustical plenum.**

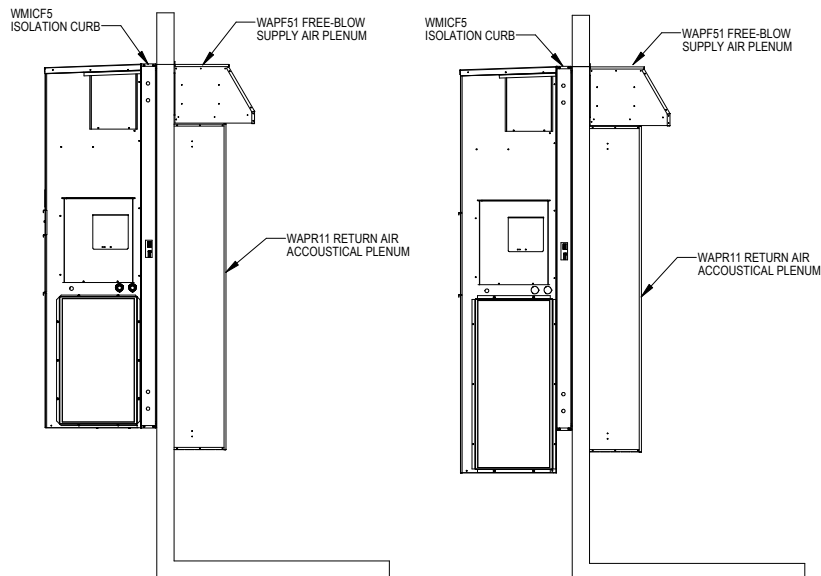

**Patent Pending**



# Typical Sound Performance with Installation/Isolation Curbs & Acoustical Plenums

## WA/L3S Sound Data Matrix (dBA @ 10 feet)

Unit Mounting	Free Blow Configuration		Ducted Supply Configuration			
	Direct	WMICF-5 Isolation Curb	Direct	Direct	WMICF-5 Isolation Curb	WMICF-5 Isolation Curb
Supply Air Treatment	Grille	WAPFB51 Free Blow Supply Air Plenum	Standard Supply Duct	Standard Supply Duct	Standard Supply Duct	WAPS51-G Supply Air Silencer
Return Air Treatment	Grille	WAPR11-X Return Air Silencer	Grille	WAPR11-X Return Air Silencer		WAPR11-X Return Air Silencer
Blower Only Operation with CRV	37.8	30.7	33.6	33.6	27.4	27.6
Compressor Stage 1 Operation with CRV	51.8	40.7	49.9	41.7	39.7	38.7
Compressor Stage 2 Operation	52.3	41.4	50.8	42.4	40.8	39.9
Compressor Stage 2 with ERV High Speed Operation	52.7	41.7	51.7	—	—	42.9
Indoor Integrated dBA	43.8	35.0	40.7	37.2	32.8	32.6
Compressor Stage 2 Outdoor Sound Level	66.9	66.9	66.9	66.9	66.9	66.9

Note 1: dBA is sound pressure measured 10 feet in front of unit and 5 feet above floor.

Note 2: Unit or isolation curb is mounted to frame construction.

Note 3: Results may vary depending upon other factors such as room size, type of construction and acoustical variances.

## WA/L4S Sound Data Matrix (dBA @ 10 feet)

Unit Mounting	Free Blow Configuration		Ducted Supply Configuration			
	Direct	WMICF-5 Isolation Curb	Direct	Direct	WMICF-5 Isolation Curb	WMICF-5 Isolation Curb
Supply Air Treatment	Grille	WAPFB51 Free Blow Supply Air Plenum	Standard Supply Duct	Standard Supply Duct	Standard Supply Duct	WAPS51-G Supply Air Silencer
Return Air Treatment	Grille	WAPR11-X Return Air Silencer	Grille	WAPR11-X Return Air Silencer		WAPR11-X Return Air Silencer
Blower Only Operation	40.1	38.9	38.4	34.5	32.8	28.2
Compressor Stage 1 Operation	52.0	41.4	50.9	41.2	40.5	39.0
Compressor Stage 2 Operation	53.7	44.0	52.9	44.3	42.0	40.5
Compressor Stage 2 with ERV High Speed Operation	55.0	46.2	54.0	—	—	44.8
Indoor Integrated dBA	45.4	40.4	44.0	37.8	35.8	33.0
Compressor Stage 2 Outdoor Sound Level	65.0	65.0	65.0	65.0	65.0	65.0

Note 1: dBA is sound pressure measured 10 feet in front of unit and 5 feet above floor.

Note 2: Unit or isolation curb is mounted to frame construction.

Note 3: Results may vary depending upon other factors such as room size, type of construction and acoustical variances.

## WA/L5S Sound Data Matrix (dBA @ 10 feet)

Unit Mounting	Free Blow Configuration		Ducted Supply Configuration			
	Direct	WMICF-5 Isolation Curb	Direct	Direct	WMICF-5 Isolation Curb	WMICF-5 Isolation Curb
Supply Air Treatment	Grille	WAPFB51 Free Blow Supply Air Plenum	Standard Supply Duct	Standard Supply Duct	Standard Supply Duct	WAPS51-G Supply Air Silencer
Return Air Treatment	Grille	WAPR11-X Return Air Silencer	Grille	WAPR11-X Return Air Silencer		WAPR11-X Return Air Silencer
Blower Only Operation	40.3	33.3	35.1	34.8	33.5	31.1
Compressor Stage 1 Operation	52.6	40.8	50.6	43.6	40.9	39.9
Compressor Stage 2 Operation	56.7	45.3	51.6	46.8	44.5	43.2
Compressor Stage 2 with ERV High Speed Operation	57.8	47.1	55.0	—	—	45.4
Indoor Integrated dBA	46.2	37.2	41.8	39.0	37.2	35.4
Compressor Stage 2 Outdoor Sound Level	65.4	65.4	65.4	65.4	65.4	65.4

Note 1: dBA is sound pressure measured 10 feet in front of unit and 5 feet above floor.

Note 2: Unit or isolation curb is mounted to frame construction.

Note 3: Results may vary depending upon other factors such as room size, type of construction and acoustical variances.

## 2nd Stage Cooling Application Data - Outdoor Temperature ①

Model	D.B./W.B. ②	Cooling Capacity BTU/HR	50°F	55°F	60°F	65°F	70°F	75°F	80°F	85°F	90°F	95°F	100°F	105°F	110°F	115°F
WA3S3 WL3S2	75/62	Total Cooling Sensible Cooling	44,125 32,375	42,850 31,850	41,600 31,300	40,325 30,775	39,050 30,225	37,800 29,700	36,550 29,200	35,300 28,700	34,050 28,200	32,800 27,700	31,475 27,025	30,150 26,350	28,825 25,675	27,500 25,000
	80/67	Total Cooling Sensible Cooling	49,150 32,375	47,675 31,800	46,175 31,225	44,675 30,650	43,200 30,075	41,700 29,500	40,125 28,894	38,550 28,300	36,975 27,675	35,400 27,075	34,225 26,625	33,075 26,175	31,900 25,750	30,750 25,300
	85/72	Total Cooling Sensible Cooling	53,150 32,075	51,700 31,550	50,250 31,050	48,800 30,525	47,350 30,025	45,900 29,500	44,475 29,000	43,050 28,500	41,625 28,000	40,200 27,500	38,650 26,925	37,100 26,350	35,550 25,775	34,000 25,200
WA4S3 WL4S2	75/62	Total Cooling Sensible Cooling	56,025 40,600	53,100 40,100	51,575 39,450	50,050 38,775	48,525 38,125	48,400 37,300	46,950 36,725	45,500 36,150	44,050 35,575	42,600 35,000	40,775 34,000	38,950 33,000	37,125 32,000	35,300 31,000
	80/67	Total Cooling Sensible Cooling	62,725 41,750	58,800 41,300	56,975 41,475	55,150 39,650	53,325 38,800	53,600 37,600	51,700 36,700	49,800 35,800	47,900 34,900	46,000 34,000	44,475 33,450	42,950 32,900	41,425 32,350	39,900 31,800
	85/72	Total Cooling Sensible Cooling	69,425 41,825	66,700 41,500	64,800 40,725	62,900 39,925	61,000 39,150	59,900 37,900	57,975 37,100	56,050 36,300	54,125 35,500	52,200 34,700	50,375 33,975	48,550 33,250	46,725 32,525	44,900 31,800
WA5S3 WL5S2	75/62	Total Cooling Sensible Cooling	69,350 49,650	67,525 48,875	65,700 48,100	63,900 47,325	62,075 46,575	60,250 45,800	58,425 45,075	56,625 44,325	54,825 43,600	53,000 42,850	51,150 41,975	49,300 41,075	47,450 40,200	45,600 39,300
	80/67	Total Cooling Sensible Cooling	74,750 48,325	72,775 47,550	70,800 46,750	68,800 45,975	66,825 45,175	64,850 44,400	62,775 43,500	60,675 42,600	58,600 41,700	56,500 40,800	54,950 40,475	53,400 40,150	51,850 39,825	50,300 39,500
	85/72	Total Cooling Sensible Cooling	79,375 46,425	77,650 45,875	75,950 45,350	74,225 44,825	72,525 44,275	70,800 43,750	69,275 43,275	67,750 42,800	66,225 42,325	64,700 41,850	62,250 41,100	59,775 40,325	57,325 39,575	54,850 38,800

## 1st Stage Cooling Application Data - Outdoor Temperature ①

Model	D.B./W.B. ②	Cooling Capacity BTU/HR	50°F	55°F	60°F	65°F	70°F	75°F	80°F	85°F	90°F	95°F	100°F	105°F	110°F	115°F
WA3S3 WL3S2	75/62	Total Cooling Sensible Cooling	30,250 22,775	29,275 22,300	28,300 21,825	27,350 21,350	26,375 20,875	25,400 20,400	24,450 19,950	23,500 19,500	22,550 19,050	21,600 18,600	20,550 18,025	19,500 17,450	18,450 16,875	17,400 16,300
	80/67	Total Cooling Sensible Cooling	34,300 23,075	33,150 22,575	32,025 22,050	30,875 21,525	29,750 21,025	28,600 20,500	27,450 19,975	26,300 19,425	25,150 18,900	24,000 18,350	22,900 17,925	21,800 17,475	20,700 17,050	19,600 16,600
	85/72	Total Cooling Sensible Cooling	37,900 22,400	36,700 22,000	35,525 21,600	34,350 21,200	33,175 20,800	32,000 20,400	30,825 20,025	29,650 19,650	28,475 19,275	27,300 18,900	26,125 18,425	24,925 17,925	23,750 17,450	22,550 16,950
WA4S3 WL4S2	75/62	Total Cooling Sensible Cooling	41,000 29,675	39,800 30,000	38,660 29,475	37,525 28,925	36,375 28,400	35,300 27,000	34,200 26,475	33,100 25,950	32,000 25,425	30,900 24,900	29,600 24,325	28,300 23,750	27,000 23,175	25,700 22,600
	80/67	Total Cooling Sensible Cooling	45,375 29,875	43,500 30,100	42,225 29,550	40,950 29,000	39,675 28,450	39,000 27,100	37,750 26,550	36,500 26,000	35,250 25,450	34,000 24,900	32,625 24,350	31,250 23,775	29,875 23,225	28,500 22,650
	85/72	Total Cooling Sensible Cooling	51,200 30,625	48,100 29,600	46,650 29,000	45,175 28,300	43,725 27,675	43,900 27,400	42,400 26,725	40,900 26,025	39,400 25,350	37,900 24,650	36,600 24,175	35,300 23,700	34,000 23,225	32,700 22,750
WA5S3 WL5S2	75/62	Total Cooling Sensible Cooling	50,375 37,125	49,050 36,575	47,725 36,050	46,400 35,525	45,075 35,000	43,750 34,450	42,550 33,975	41,350 33,500	40,150 33,025	38,950 32,550	37,150 31,775	35,325 31,025	33,525 30,275	31,700 29,500
	80/67	Total Cooling Sensible Cooling	58,925 36,900	56,900 36,400	54,900 35,875	52,900 35,375	50,875 34,850	48,850 34,350	46,650 33,450	44,425 32,525	42,225 31,625	40,000 30,700	38,775 31,825	37,550 32,925	36,325 34,050	35,100 35,150
	85/72	Total Cooling Sensible Cooling	62,550 36,250	60,800 35,775	59,050 35,300	57,300 34,825	55,550 34,375	53,800 33,900	52,050 33,475	50,275 33,025	48,525 32,600	46,750 32,150	45,050 31,600	43,350 30,975	41,650 30,400	39,950 29,800

① Below 50°F, unit requires a factory or field-installed low ambient control.

② Return air temperature °F.

### Clearances Required for Service Access and Adequate Condenser Airflow Intake

MODELS	LEFT SIDE	RIGHT SIDE
WA/L3S, WA/L4S, WA/L5S	20"	20"

### Minimum Clearances Required to Combustible Materials

MODELS ①	SUPPLY AIR DUCT FIRST THREE FEET	CABINET
WA/L3S, WA/L4S, WA/L5S	1/4"	0"

① Refer to the Installation Manual for more detailed information.

## Dimensions of Basic Unit for Architectural & Installation Requirements (Nominal)

MODEL	WIDTH (W)	DEPTH (D)	HEIGHT (H)	SUPPLY		RETURN																	
				A	B	C	B	E	F	G	I	J	K	L	M	N	O	P	Q	R	S1	S2	T
WA3S3 WL3S2	42.075	22.432	84.875	9.88	29.88	15.88	29.88	43.88	13.56	31.66	30.00	32.68	26.94	34.69	32.43	3.37	43.00	23.88	10.00	1.44	16.00	16.00	1.88
WA4S3 WL4S2 WA5S3 WL5S2	42.075	22.432	94.875	9.88	29.88	15.88	29.88	43.88	13.56	41.66	30.00	42.68	36.94	44.69	42.43	3.37	43.00	33.88	10.00	1.44	16.00	21.00	1.88

All dimensions are in inches. Dimensional drawings are not to scale.

### WA3-4-5S Models

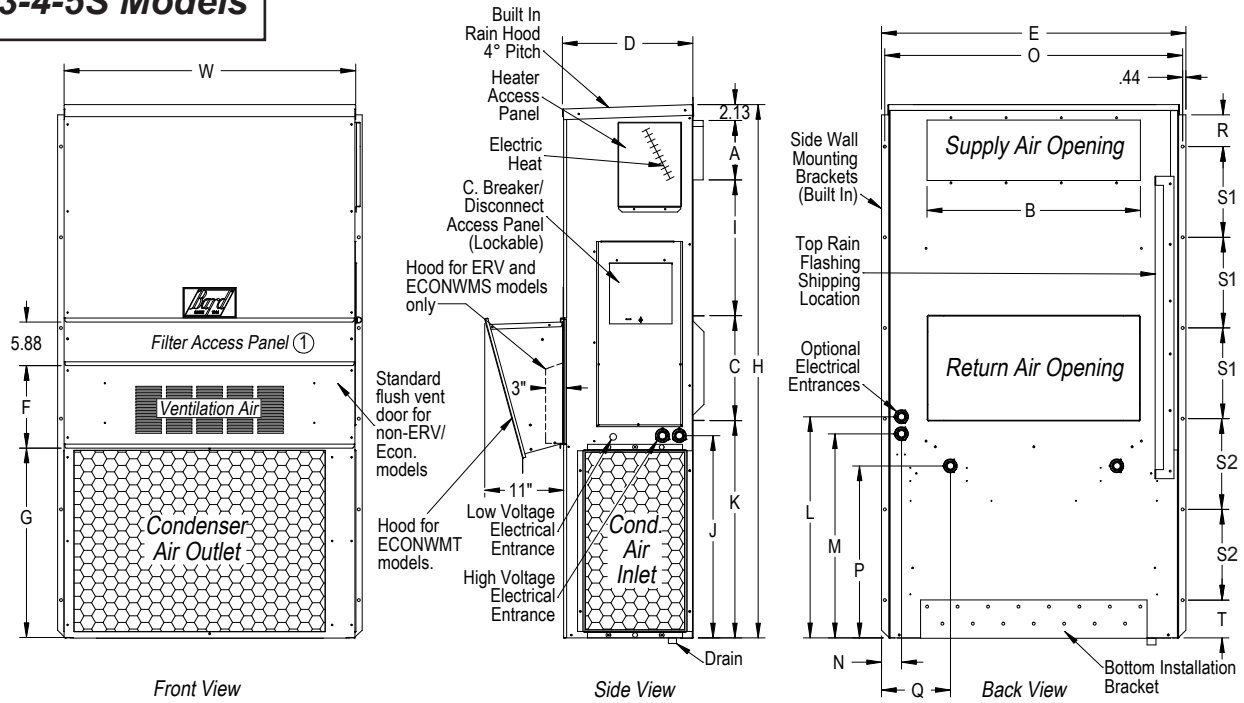

MIS-3234

### WL3-4-5S Models

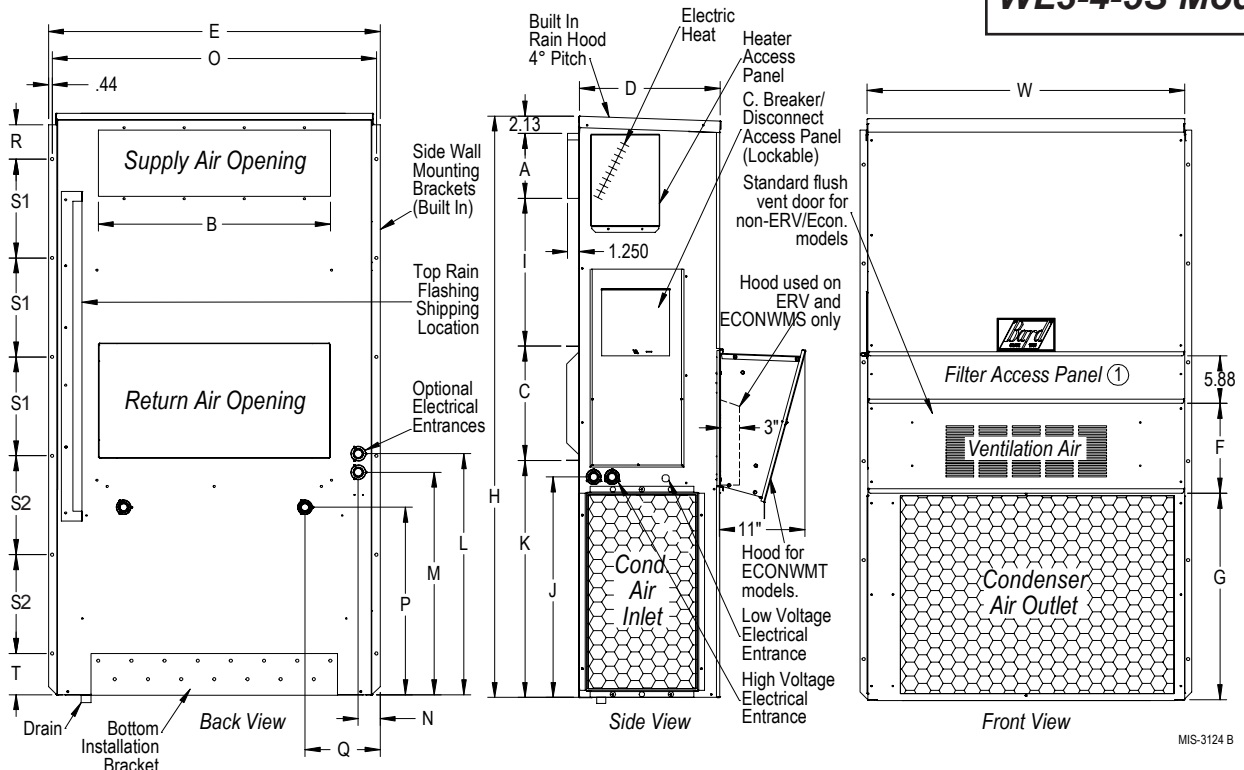

MIS-3124 B

## Air Conditioning Wall-Mount Model Nomenclature

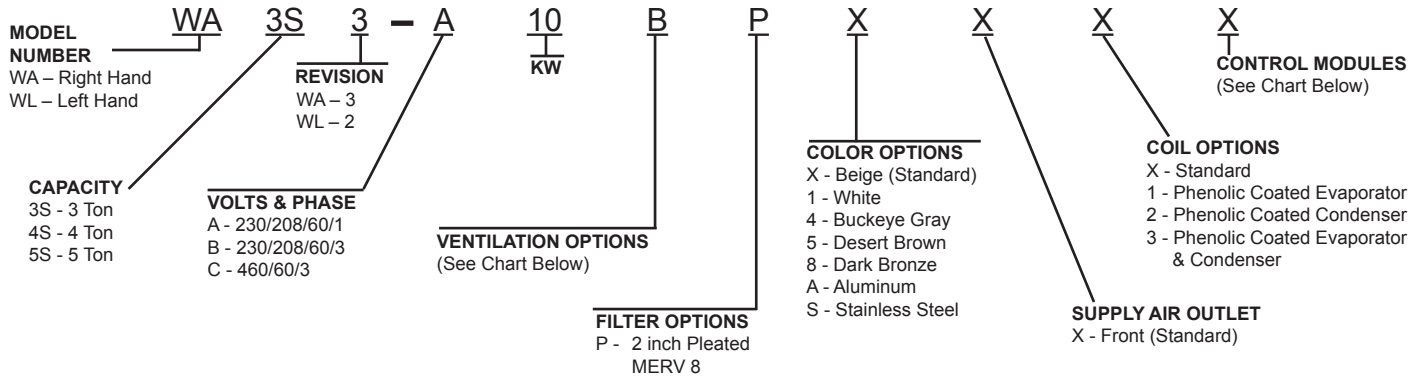

Note: For 0KW and circuit breakers (230/208 Volt) or rotary disconnect (460 Volt) applications, insert 0Z in the KW field of the model number.

### Ventilation Options

Models	All Models	
	Factory Installed Code No.	Field Installed Part No.
Blank-Off Plate	B	BOP-5
Motorized Fresh Air Damper	M	MFAD-5
Commercial Ventilator - Motorized w/Exhaust	V	CRVMP-5
Economizer - Standard Versions, Enthalpy ④	S	ECONWMS-E5B ②
Economizer - Equipment Building, Enthalpy ⑤	W	ECONWMT-E5B ②
Economizer - Equipment Building, DB Temp ⑤	T	ECONWMT-T5B ②
Energy Recovery Ventilator - 230 Volt ③	R	ERVF-A5 ①
Energy Recovery Ventilator - 460 Volt ③	R	ERVF-C5 ①
Door Kit for ERVF (Required)	N/A	WMDK5- ③

- ① Intake and exhaust can be independently adjusted.
- ② Insert color to match unit ("X" = Beige; "4" = Buckeye Gray; etc.)
- ③ WMDK Door Kit must be ordered in addition to ERVF Assembly and color matched to unit ("X" = Beige; "4" = Buckeye Gray; etc.)
- ④ Partial Full Flow (75% of Rated Cooling CFM). All ECONWMS versions have 3" deep intake hood.
- ⑤ Full Flow (100% of Rated Cooling CFM).

### Air Conditioning Control Modules

AVAILABLE CONTROL OPTIONS							ALL MODELS	
HPC ①	LPC ②	CCM ③	LAC ④	ALR ⑤	SK ⑥	DDC ⑦	Factory Installed Code	Field Installed Part
STD	STD	STD			STD		X	N/A
STD	STD	STD	●		STD		H	CMA-28
STD	STD	STD	●	●	STD		J	Factory Only
STD	STD	STD	●	●	STD	●	V ⑦	Factory Only

STD = Standard equipment for these specified models.

- ① HPC. High pressure control is auto reset. Always used with compressor control module (CCM) which is included. See note ③.
- ② LPC. Low pressure control is auto reset. Always used with compressor control module (CCM) which is included. See note ③.
- ③ CCM. Compressor control module has adjustable 30-second to 5-minute delay-on-break timer. On initial power-up, or any time the power is interrupted, the delay-on-make will be 2-minutes plus 10% of the delay-on-break setting. There is no delay-on-make during routine operation of the unit. The module also provides the lockout feature (with 1 retry) for high and/or low-pressure controls, and a 2-minute timed bypass for low-pressure control.
- ④ LAC. Low ambient control permits cooling operation down to 0°F.
- ⑤ ALR. The alarm relay has a set of normally open and normally closed dry contacts to provide the ability to signal a condition of shutdown on either high or low pressure controls.
- ⑥ SK. Start kit standard on all -A single phase models only. Is not used or available for -B or -C three phase models.
- ⑦ DDC. Incorporates 4 additional sensors: discharge air temperature, indoor blower airflow, compressor current, and dirty filter. These sensing devices function to input analog data such as temperature, as well as digital data such as airflow, compressor status or filter status.



Bard Manufacturing Company, Inc.  
Bryan, Ohio 43506  
www.bardhvac.com

**Due to our continuous product improvement policy, all specifications subject to change without notice.**

Before purchasing this appliance, read important energy cost and efficiency information available from your retailer.

**Form No.**  
**S3378**  
**September, 2014**

Supersedes: S3378-1013