



The Wall-Mount™ Variable Capacity Environmental Control Units



**3, 5 and 6-Ton Variable Capacity ECU
Dual 60/50 Hz Frequency
Cooling Op Range -40F to +131F ODT**

**GREEN REFRIGERANT
R-410A**



The Bard Variable Capacity ECU design is a world-class machine designed to operate from -40F to +131F (-40C to +55C) outdoor temperature range. All versions employ a digital compressor capable of continuously modulating capacity from 100% down to 20%, controlled by a Bard digital thermostat/controller that is supplied with each ECU. The indoor and outdoor motors are also ECM variable speed to maintain peak airflow performance under all conditions. All ECU's are dual 60/50 Hz frequency rated suitable for use anywhere in the world within the specified operating voltage range. These ECU's are the ideal product for all applications where extreme duty conditions exist and must be able to operate with whatever power supply is available - be it shore power or standby power supply.

Engineered Features

Aluminum Finned Copper Coils:

Grooved tubing and enhanced louvered fin for maximum heat transfer and energy efficiency. Phenolic coated coils available and recommended for maximum durability in all harsh environments.

ECU Compressor:

Digital scroll compressor is used in all models providing 60/50 Hz operation and variable capacity from 100% down to 20% allowing continuous operation while matching the cooling load of the structure. Crankcase heaters are standard. PTCR motor starting device standard on 1-phase.

Thermostatic Expansion Valve:

For wide range refrigerant control.

Indoor and Outdoor Motors:

Both motors are ECM variable speed design to maintain performance and air delivery under all conditions. Outdoor condenser motor is totally enclosed and has modulating low ambient feature.

Twin Blowers:

All ECU's have a twin blower system and ECM motor with overload protection.

R-410A Refrigerant:

Designed with R-410A (HFC) non-ozone depleting refrigerant in compliance with the Montreal protocol and 2010 EPA requirements.

Phase Rotation Monitor:

Standard on all 3 phase scroll compressors. Protects against reverse rotation if power supply is not properly connected.

Galvanized 20 Gauge Zinc Coated Steel Cabinet:

Cleaned, rinsed, sealed and dried before the polyurethane primer is applied. The cabinet is handsomely finished with a baked on textured enamel, which allows it to withstand 1000 hours of salt spray tests per ASTM B117-03.

Aluminum and Stainless Steel cabinets are also available. Stainless Steel recommended for maximum durability in all harsh environments.

Digital Thermostat/Controller:

A dedicated thermostat/controller is standard and supplied with each ECU. This device is required for proper operation of the ECU.

Electrical Components:

Are easily accessible for routine inspection and maintenance through an Extreme Duty water and dust tight gasketed and insulated door. Door is equipped with 2 locking cam latches providing access to the circuit breaker or toggle (460/400V only) disconnect switch. Internal control panel cover is easily removable if required. Extreme Duty door is standard. See Nomenclature on Page 8 for Optional Moderate Duty flush control panel cover.

Electric Heat Strips:

Features an automatic limit and thermal cut-off safety control. Heater packages can be factory or field installed.

Filter Service Door:

Separate service door provides easy access for filter change.

One Inch, Disposable Air Filters:

Are standard equipment. Optional one inch washable filters available and filter racks permit the addition of 2" pleated filter. Factory or field installed.

Condenser Fan and Motor

Shroud Assembly:

Slides out for easy access.

Barometric Fresh Air Damper:

Standard on all units. Allows up to 25% outside fresh air, intake only. Actual amount of outdoor air introduced governed by other building systems. Optional blank-off plate available.

Built-in Circuit Breakers:

Standard on all electric heat versions of single (230/208 volt) and three phase (230/208 volt) equipment. Toggle disconnects are standard on all electric heat versions of three phase (460 volt) equipment.

Liquid Line Filter Drier:

Standard on all units. Protects system against moisture.

Compressor Control Module:

Standard on all units. Built-in off-delay timer adjustable from 30 seconds to 5 minutes. 2-minute on-delay if power interrupt. 120-second bypass for low pressure control, and both soft and manual lockouts for high and low pressure controls. Alarm output for alarm relay.



Refrigerant Alarm Relay:

Standard on all units. SPDT dry contacts offer both N.O. and N.C. alarm strategy capability.

High & Low Pressure Switches are Auto-Reset:

Standard on all units. Built-in lockout circuit resets from the room thermostat. Provides commercial quality protection to the compressor.

Accumulator:

Standard on all models for refrigerant management.

Foil Faced Insulation:

Standard on all units.

Full Length Mounting Brackets:

Built into cabinet for improved appearance and easy installation. NOTE: Bottom mounting bracket included to assist in installation.

Slope Top:

Standard feature for water run-off.

Top Rain Flashing:

Standard feature on all models.

PTCR Motor Starting Device:

Standard on 1-phase models, increases compressor motor starting torque 2-3 times. Optional factory or field installed hard start kit available, replaces PTCR device.

Wall Mount Variable Capacity Environmental Control Units (ECU)

Model Number	Configuration	Compressor & Control Access	60 Hz Capacity			50 Hz Capacity		Electric Heat KW Options at 240 or 480V
			Rated Capacity BTUH (KW) ①	EER ①	Capacity Modulation Range BTUH (KW)	Nominal Capacity BTUH (KW)	Capacity Modulation Range BTUH (KW)	
W3RV1-R W3RV1-S W3RV1-T	Wall-Mount	Right Side	35,000 (10.25)	9.0	7,400 - 35,000 (2.17 to 10.25)	32,000 (9.38)	6,740 - 32,000 (1.97 to 9.38)	5, 10 6, 9 9, 12
W3LV1-R W3LV1-S W3LV1-T	Wall-Mount	Left Side	35,000 (10.25)	9.0	7,400 - 35,000 (2.17 to 10.25)	32,000 (9.38)	6,740 - 32,000 (1.97 to 9.38)	5, 10 6, 9 9, 12
W5RV1-R W5RV1-S W5RV1-T	Wall-Mount	Right Side	53,000 (15.53)	9.0	10,800 - 53,000 (3.16 to 15.53)	48,000 (14.06)	9,840 - 48,000 (2.88 to 14.06)	10, 20 9, 18 9, 15
W5LV1-R W5LV1-S W5LV1-T	Wall-Mount	Left Side	53,000 (15.53)	9.0	10,800 - 53,000 (3.16 to 15.53)	48,000 (14.06)	9,840 - 48,000 (2.88 to 14.06)	10, 20 9, 18 9, 15
W6RV1-S W6RV1-T	Wall-Mount	Right Side	67,000 (19.63)	9.0	13,600 - 67,000 (3.98 to 19.63)	61,000 (17.87)	12,380 - 61,000 (3.63 to 17.87)	9, 18 9, 15
W6LV1-S W6LV1-T	Wall-Mount	Left Side	67,000 (19.63)	9.0	13,600 - 67,000 (3.98 to 19.63)	61,000 (17.87)	12,380 - 61,000 (3.63 to 17.87)	9, 18 9, 15

① Rated capacity and EER at 95F outdoor and 80F DB/67F WB in accordance with ANSI/AHRI Standard 390-2003 and compressor operating at 100% output.

Model Number	60 Hz Electrical		50 Hz Electrical		Electrical Wiring System	Outdoor Operating Range	Cabinet Size H x W x D Inches (cm)
	60 Hz Electrical Rating	60 Hz Operating Voltage Range	50 Hz Electrical Rating	50 Hz Operating Voltage Range			
W3RV1-R W3RV1-S W3RV1-T	230/208-60-1 230/208-60-3 460-60-3	197 - 253 197 - 253 414 - 506	220/200-50-1 220/200-50-3 400-50-3	180 - 240 180 - 240 360 - 440	2 wire + ground 3 wire + ground 3 wire + ground	-40F to +131F (-40C to +55C)	70.57x38.20x17.13 (179.25x97.03x43.50)
W3LV1-R W3LV1-S W3LV1-T	230/208-60-1 230/208-60-3 460-60-3	197 - 253 197 - 253 414 - 506	220/200-50-1 220/200-50-3 400-50-3	180 - 240 180 - 240 360 - 440	2 wire + ground 3 wire + ground 3 wire + ground	-40F to +131F (-40C to +55C)	70.57x38.20x17.13 (179.25x97.03x43.50)
W5RV1-R W5RV1-S W5RV1-T	230/208-60-1 230/208-60-3 460-60-3	197 - 253 197 - 253 414 - 506	220/200-50-1 220/200-50-3 400-50-3	180 - 240 180 - 240 360 - 440	2 wire + ground 3 wire + ground 3 wire + ground	-40F to +131F (-40C to +55C)	84.88x42.08x22.43 (215.58x106.87x56.98)
W5LV1-R W5LV1-S W5LV1-T	230/208-60-1 230/208-60-3 460-60-3	197 - 253 197 - 253 414 - 506	220/200-50-1 220/200-50-3 400-50-3	180 - 240 180 - 240 360 - 440	2 wire + ground 3 wire + ground 3 wire + ground	-40F to +131F (-40C to +55C)	84.88x42.08x22.43 (215.58x106.87x56.98)
W6RV1-S W6RV1-T	230/208-60-3 460-60-3	197 - 253 414 - 506	220/200-50-3 400-50-3	180 - 240 360 - 440	3 wire + ground 3 wire + ground	-40F to +131F (-40C to +55C)	94.88x42.08x22.43 (240.98x106.87x56.98)
W6LV1-S W6LV1-T	230/208-60-3 460-60-3	197 - 253 414 - 506	220/200-50-3 400-50-3	180 - 240 360 - 440	3 wire + ground 3 wire + ground	-40F to +131F (-40C to +55C)	94.88x42.08x22.43 (240.98x106.87x56.98)

Model Number	W3RV/W3LV-R	W3RV/W3LV-S	W3RV/W3LV-T	W5RV/W5LV-R	W5RV/W5LV-S	W5RV/W5LV-T	W6RV/W6LV-S	W6RV/W6LV-T
Shipping Weight Lbs (Kg)	410 (186)	410 (186)	440 (200)	560 (254)	560 (254)	600 (272)	610 (277)	650 (295)

Electrical Ratings	Environmental Control Unit						Major Components					
	60 Hz			50 Hz			Compressor		Indoor Motor		Outdoor Motor	
	Voltage	Phase	Operating Voltage Range	Voltage	Phase	Operating Voltage Range	RLA	LRA	HP	FLA	HP	FLA
W3RV1 / W3LV1-R	230/208	1	197 - 253	220/200	1	180 - 240	15.6/15.6	112	1/2	2.7	1/3	2.1
W3RV1 / W3LV1-S	230/208	3	197 - 253	220/200	3	180 - 240	9.9/9.9	88	1/2	2.7	1/3	2.1
W3RV1 / W3LV1-T	460	3	414 - 506	400	3	360 - 440	5.3	44	1/2	2.7	1/3	2.1
W5RV1 / W5LV1-R	230/208	1	197 - 253	220/200	1	180 - 240	24.2/24.0	134	1/2	2.5	1/2	3.9
W5RV1 / W5LV1-S	230/208	3	197 - 253	220/200	3	180 - 240	16.0/15.9	110	1/2	2.5	1/2	3.9
W5RV1 / W5LV1-T	460	3	414 - 506	400	3	360 - 440	7.7	52	1/2	2.5	1/2	3.9
W6RV1 / W6LV1-S	230/208	3	197 - 253	220/200	3	180 - 240	28.5/22.7	144	1/2	2.5	1/2	3.9
W6RV1 / W6LV1-T	460	3	414 - 506	400	3	360 - 440	14.0	75	1/2	2.5	1/2	3.9

Indoor Blower Performance – CFM (0.00" - 0.50" H₂O)

MODELS	Rated CFM	Rated E.S.P. @ Rated CFM	CFM Modulation Range ①	Filter Size
W3RV1 / W3LV1	1100	0.15"	1100 - 550	16 x 30
W5RV1 / W5LV1	1700	0.20"	1700 - 850	20 x 30
W6RV1 / W6LV1	1700	0.20"	1700 - 850	20 x 30

① CFM will modulate from 100% down to 50% to match system capacity modulation as standard operation. There is an option in the thermostat/controller schedule to lock the CFM at the rated 100% value.

Electrical Specifications

Model	Electrical Rating: Volts Hz Phase	No. Field Power Circuits	Single Circuit				Dual Circuit													
			③ Minimum Circuit Ampacity	① Maximum Overcurrent Protection	② Field Power Wire Size	④ Ground Wire	③ Minimum Circuit Ampacity			① Maximum Overcurrent Protection			② Field Power Wire Size			④ Ground Wire Size				
							Ckt. A	Ckt. B	Ckt. C	Ckt. A	Ckt. B	Ckt. C	Ckt. A	Ckt. B	Ckt. C	Ckt. A	Ckt. B	Ckt. C		
W3RV1 / W3LV1-ROZ R05 R10	230/208-60-1 220/200-50-1	1 1 1 or 2	28	35	8	10	N/A	N/A	N/A	N/A	N/A	N/A	N/A	N/A	N/A	N/A	N/A	N/A	N/A	N/A
			54	60	6	10	N/A	N/A	N/A	N/A	N/A	N/A	N/A	N/A	N/A	N/A	N/A	N/A	N/A	N/A
			80	80	4	8	54	26	N/A	60	30	N/A	6	10	N/A	10	N/A	10	10	N/A
W3RV1 / W3LV1-SOZ S06 S09	230/208-60-3 220/200-50-3	1 1 1	19	30	10	10	N/A	N/A	N/A	N/A	N/A	N/A	N/A	N/A	N/A	N/A	N/A	N/A	N/A	N/A
			37	40	8	10	N/A	N/A	N/A	N/A	N/A	N/A	N/A	N/A	N/A	N/A	N/A	N/A	N/A	
			46	50	8	10	N/A	N/A	N/A	N/A	N/A	N/A	N/A	N/A	N/A	N/A	N/A	N/A	N/A	
W3RV1 / W3LV1-TOZ T09 T12	460-60-3 400-50-3	1 1 1	12	15	14	14	N/A	N/A	N/A	N/A	N/A	N/A	N/A	N/A	N/A	N/A	N/A	N/A	N/A	N/A
			25	25	10	10	N/A	N/A	N/A	N/A	N/A	N/A	N/A	N/A	N/A	N/A	N/A	N/A		
			29	30	10	10	N/A	N/A	N/A	N/A	N/A	N/A	N/A	N/A	N/A	N/A	N/A	N/A		
W5RV1 / W5LV1-ROZ R10 R20	230/208-60-1 220/200-50-1	1 1 or 2 1 or 3	39	60	8	10	N/A	N/A	N/A	N/A	N/A	N/A	N/A	N/A	N/A	N/A	N/A	N/A	N/A	N/A
			91	100	3	8	39	52	N/A	60	60	N/A	8	6	N/A	10	10	N/A		
			143	150	10	6	39	52	52	60	60	60	8	6	6	10	10	10		
W5RV1 / W5LV1-SOZ S09 S18	230/208-60-3 220/200-50-3	1 1 2	28	40	8	10	N/A	N/A	N/A	N/A	N/A	N/A	N/A	N/A	N/A	N/A	N/A	N/A	N/A	N/A
			55	60	6	10	N/A	N/A	N/A	N/A	N/A	N/A	N/A	N/A	N/A	N/A	N/A	N/A		
			N/A	N/A	N/A	N/A	55	28	N/A	60	30	N/A	6	10	N/A	10	10	N/A		
W5RV1 / W5LV1-TOZ T09 T15	460-60-3 400-50-3	1 1 1	18	25	10	10	N/A	N/A	N/A	N/A	N/A	N/A	N/A	N/A	N/A	N/A	N/A	N/A	N/A	N/A
			32	35	8	10	N/A	N/A	N/A	N/A	N/A	N/A	N/A	N/A	N/A	N/A	N/A			
			41	45	8	10	N/A	N/A	N/A	N/A	N/A	N/A	N/A	N/A	N/A	N/A	N/A			
W6RV1 / W6LV1-SOZ S09 S18	230/208-60-3 220/200-50-3	1 2 2	42	60	8	10	N/A	N/A	N/A	N/A	N/A	N/A	N/A	N/A	N/A	N/A	N/A	N/A	N/A	N/A
			N/A	N/A	N/A	N/A	42	28	N/A	60	30	N/A	8	10	N/A	10	10	N/A		
			N/A	N/A	N/A	N/A	42	55	N/A	60	60	N/A	8	6	N/A	10	10	N/A		
W6RV1 / W6LV1-TOZ T09 T15	460-60-3 400-50-3	1 1 1	22	35	8	10	N/A	N/A	N/A	N/A	N/A	N/A	N/A	N/A	N/A	N/A	N/A	N/A	N/A	N/A
			36	45	8	10	N/A	N/A	N/A	N/A	N/A	N/A	N/A	N/A	N/A	N/A	N/A			
			45	50	8	10	N/A	N/A	N/A	N/A	N/A	N/A	N/A	N/A	N/A	N/A	N/A			

① Maximum size of the time delay fuse or HACR type circuit breaker for protection of field wiring conductors.

② Based on 75C copper wire. All wiring must conform to the National Electrical Code and all local codes.

③ These "Minimum Circuit Ampacity" values are to be used for sizing the field power conductors. Refer to the National Electrical code (latest version), Article 310 for power conductor sizing.

Caution: When more than one field power circuit is run through one conduit, the conductors must be derated. Pay special attention to note 8 of Table 310 regarding Ampacity Adjustment Factors when more than three (3) current carrying conductors are in a raceway.

* Top outlet supply option is available only factory installed and only on the selected models.

IMPORTANT: While this electrical data is presented as a guide, it is important to electrically connect properly sized fuses and conductor wires in accordance with the National Electrical Code and all local codes.

Heater Packages - Field Installed

- Designed for adding Electric Heat to 0 KW Units
- Circuit Breaker Standard on 230/208V Models

- ETL US & Canada Listed
- Toggle Disconnect Standard on 460V Models

Models	-R Models 230/208-1		-S Models 230/208-3		-T Models 460-3	
	Heater Model #	KW	Heater Model #	KW	Heater Model #	KW
W3RV1	EHWH36-A05	5	EHWH03-B06	6	EHW36A-C09	9
	EHWH36-A10	10	EHWH03-B09	9	EHW36A-C12	12
W5RV1	EHWH04-A10	10	EHWH05-B09	9	EHW05A-C09	9
	EHWA05HA20	20	EHW70A-B18	18	EHW05A-C15	15
W6RV1			EHW70AHB09	9	EHW05A-C09	9
			EHW70AHB18	18	EHW05A-C15	15
W3LV1	EHW36AHA05L	5	EHW36AHB06L	6	EHW36AHC09L	9
	EHW36AHA10L	10	EHW36AHB09L	9	EHW36AHC12L	12
W5LV1	EHWH04-A10L	10	EHWA05HB09L	9	EHW05L-C09	9
	EHWL05HA20	20	EHW70L-B18	18	EHW05L-C15	15
W6LV1			EHW70LHB09	9	EHW05L-C09	9
			EHW70LHB18	18	EHW05L-C15	15

Electric Heat Table

Nominal KW @ 240V 60 or 50Hz	1-Phase Heater Ratings at Other Applied Voltages														
	@ 240V			@ 230V			@ 220V			@ 208V			@ 200V		
	KW	BTUH	Amps	KW	BTUH	Amps	KW	BTUH	Amps	KW	BTUH	Amps	KW	BTUH	Amps
5	5.0	17,065	20.80	4.59	15,666	19.90	4.20	14,335	19.10	3.76	12,833	18.06	3.47	11,843	17.36
10	10.0	34,130	41.60	9.18	31,331	39.93	8.40	28,669	38.19	7.51	25,632	36.11	6.94	23,686	34.72
20	20.0	68,260	62.50	18.37	62,697	79.86	16.81	57,373	76.39	15.02	51,263	72.22	13.89	47,407	69.44

Nominal KW @ 240 or 480V 60 or 50Hz	3-Phase Heater Ratings at Other Applied Voltages														
	@ 240 or 480V			@ 230 or 460V			@ 220 or 440V			@ 208 or 415V			@ 200 or 400V		
	KW	BTUH	Amps 240/480V	KW	BTUH	Amps 230/460V	KW	BTUH	Amps 220/440V	KW	BTUH	Amps 208/415V	KW	BTUH	Amps 200/400V
6	6.0	20,478	14.43/7.22	5.51	18,806	13.83/6.92	5.04	17,202	13.23/6.62	4.51	15,393	12.51/6.24	4.17	14,232	12.03/6.01
9	9.0	30,717	21.65/10.83	8.27	28,226	20.75/10.37	7.56	25,802	19.85/9.92	6.76	23,072	18.76/9.36	6.25	21,331	18.04/9.02
12	12.0	40,956	28.87/14.43	11.02	37,611	27.67/13.83	10.08	34,403	26.46/13.23	9.01	30,751	25.02/12.48	8.33	28,430	24.06/12.03
15	15.0	51,195	36.09/18.04	13.78	47,031	34.58/17.29	12.6	43,004	33.08/16.54	11.27	38,465	31.27/15.60	10.42	35,563	30.07/15.04
18	18.0	61,434	43.30/21.65	16.53	56,417	41.50/20.75	15.13	51,639	39.69/19.85	13.52	46,144	37.53/18.72	12.50	42,663	36.09/18.04

ECU OPERATING CONTROL SYSTEM

The W3R/LV1 through W6R/LV1 variable capacity air conditioners utilize dedicated controllers and components to optimize this unit for cooling operation from -40 degrees F up to 131 degrees F (-40 degrees C to +55 degrees C). These units are dual rated for 200-240V operation on both 50 and 60 Hz. Please read the following sequence of operation before attempting any troubleshooting or repair. Troubleshooting and repair procedures will be outlined later (Page 5).

These models use a digital compressor and variable speed indoor and outdoor motors. The motors and compressor must be replaced with the exact same component to maintain the above stated temperature and voltage ranges of operation. The units are controlled by a Bard digital thermostat/controller. This thermostat/controller contains proprietary programming and must be placed with the exact same component to ensure proper operation.

13-conductor 18 gauge control cable should be used for making connections from thermostat/controller to the ECU.

Lead/Lag sequence available by special application of the 8403-066 Digital Controllers. Consult ECU Installation Instructions.

DIGITAL THERMOSTAT/CONTROLLER

Terminal	Function	Type	Form
+B	MSTP + (not used)	Communications	
-A	MSTP - (not used)	Communications	
IN4	Outdoor Temperature Sensor	Input	10K OHM Type 3
IN3	Pressure Transducer	Input	0-5 VDC, 0-700 PSIG
GND	Sensor Grounds	Input	
IN2	Lockout Alarm	Input	Relay Closure
24 COM	24VAC Com	Power	
24V	24VAC	Power	
OUT 9	Fan Motor Control	Analog Output	0-10VDC
GND7-9	Control Ground	Analog Output	
OUT 8	Unloader Solenoid Control	Analog Output	0 or 5VDC PWM
OUT 7	Blower Motor Control	Analog Output	0-10VDC
RLY 4	Heater Contactor #1	Relay Output	Relay
SC 4-6	24VAC to Relay Outputs 4-6	Power	
RLY 5	Heater Contactor #2	Relay Output	Relay
RLY 6	(not used)		
RLY 3	(not used)		
SC 1-3	24VAC to Relay Outputs 1-3	Power	
RLY 2	Compressor Contactor	Relay Output	Relay
RLY 1	(not used)		

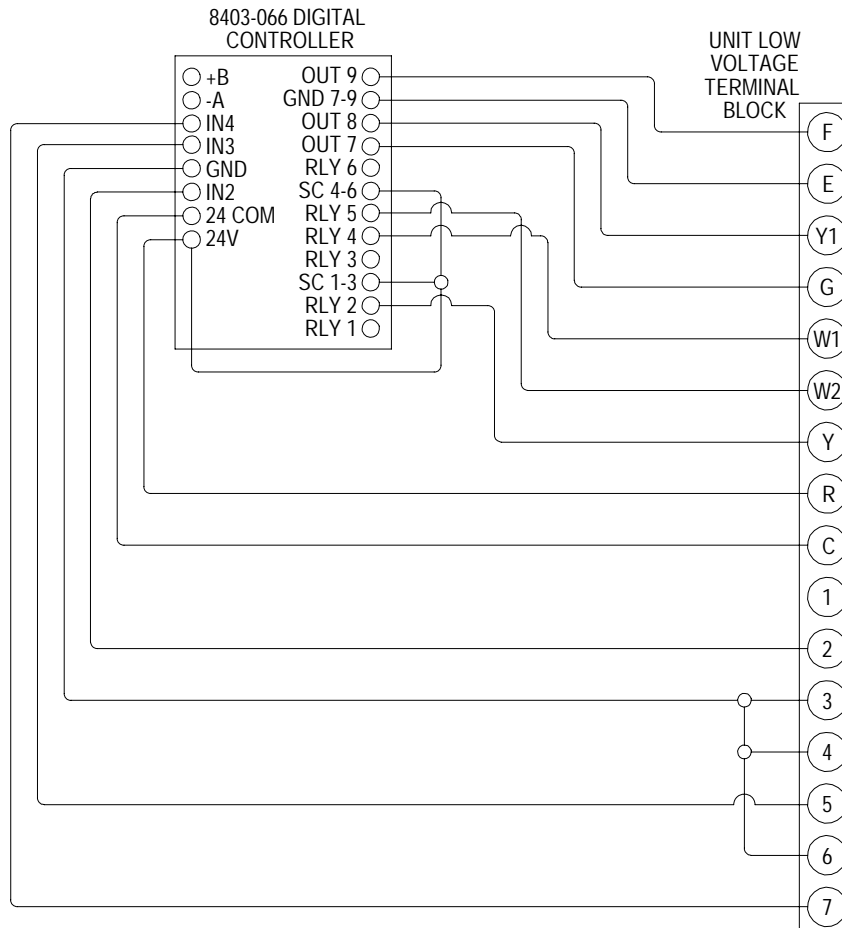

MIS-2852 C

SEQUENCE OF OPERATION

MODES OF OPERATION

Cool Only Mode:

- Compressor will modulate from 100% down to 20%.
- Compressor will cycle off if thermostat/controller set-point is reached.

Heat Only Mode:

- Electric heat Stage 1 operates at 1st-stage heating set-point.
- Electric heat Stage 2 (if equipped) operates on 2nd-stage (-2F below heating set-point).

Auto Mode:

- Cooling or heating automatically selected based on building temperature vs. thermostat/controller set-points and operates as described above.

CCVC (Continuous Compressor Variable Capacity):

- Compressor will modulate from 100% down to 20%.
- Compressor will not cycle off if thermostat/controller set-point is reached, and would stay running at the 20% minimum capacity.
- If space temperature drops -2F below cooling set-point electric heat Stage 1 will then cycle to maintain that condition.
- If Stage 2 electric heat is installed, and if required, will cycle at -4F below cooling set-point to maintain that condition.
- If CCVC is terminated the controller will revert to Cool or Auto operation.
- CCVC would be an Operating Mode for all applications where continuous run of the compressor is a requirement.

CCFC (Continuous Compressor Fixed Capacity):

- The compressor is turned ON and locked ON as long as the thermostat/controller is in CCFC.
- When in CCFC the compressor does not modulate but will be locked ON at 100% capacity.
- If space temperature drops -2F below cooling set-point electric heat Stage 1 will then cycle to maintain that condition.
- If Stage 2 electric heat is installed, and if required, will cycle at -4F below cooling set-point to maintain that condition.
- If CCFC is terminated the controller will revert to Cool or Auto operation.
- CCFC would not be considered an Operating Mode and should only be used for system testing as required.

Indoor Blower Operation

The indoor blower speed will modulate with the compressor operation from 50% to 100% of operation. Once compressor operation is at 50 or below, percent airflow will be at 50% and no further reduction of airflow will occur. Modulation is accomplished by modulating a 0-10 volt signal from OUT 7 to the indoor blower control board which then sends a PWM signal to the indoor blower motor.

An additional option to maintain airflow at 100% is also available.

Outdoor Fan Motor Operation

The outdoor fan motor speed is varied in response to outdoor air temperature and pressure. The fan motor will cycle on and off with the compressor when not in a CCVC or CCFC. At all times above 122 degrees OAT, the outdoor fan, OUT 9, will be energized at high speed. From 122 degrees to 55 degrees the outdoor fan, OUT 9, will be set at normal outdoor airflow. Below 55 degrees the outdoor fan will modulate to maintain a 300 psi head pressure. This will act as a low ambient fan cycling control. The output may go to zero output to maintain the 300 PSI. The

outdoor ECM motor will be programmed with a minimum RPM allowed to protect the bearing system. Any signal that is less than the percent torque required to maintain the minimum RPM will cause the motor to shut off. Once head pressure rises the motor will restart.

COOLING SEQUENCE

Compressor Operation

The cooling capacity of the WV series is controlled by loading or unloading the compressor. On a call for cooling, the unloader solenoid is energized for one second to ensure pressure equalization in the compressor. The compressor contactor, RLY 2, is then energized and the compressor will start. A PI control loop then calculates the compressor capacity needed to reach set point and modulates the compressor. Modulation range is from 20% to 100% capacity. Modulation is accomplished by a pulse width modulated signal from OUT 8 which energizes the solid state relay (SSR) and energizes or de-energizes the unloader solenoid. The required compressor capacity is calculated every 15 seconds.

20% load means 0 VDC for 3.0 seconds and 5 VDC for 12.0 seconds from OUT 8.

30% load means 0 VDC for 4.5 seconds and 5 VDC for 10.5 seconds from OUT 8.

40% load means 0 VDC for 6.0 seconds and 5 VDC for 9.0 seconds from OUT 8.

50% load means 0 VDC for 7.5 seconds and 5 VDC for 7.5 seconds from OUT 8.

60% load means 0 VDC for 9.0 seconds and 5 VDC for 6.0 seconds from OUT 8.

70% load means 0 VDC for 10.5 seconds and 5 VDC for 4.5 seconds from OUT 8.

80% load means 0 VDC for 12.0 seconds and 5 VDC for 3.0 seconds from OUT 8.

90% load means 0 VDC for 13.5 seconds and 5 VDC for 1.5 seconds from OUT 8.

100% load means 0 VDC for 15 seconds and 5 VDC for 0.0 seconds from OUT 8.

HEATING SEQUENCE

On a call for heating, if the space temperature falls 1°F below setpoint, the first stage of heating, RLY 4, will cycle ON. If the space temperature falls 3°F below setpoint, the second stage of heating, RLY 5, will cycle ON. Indoor Blower airflow is maintained at the Rated unit airflow at all times during heating.

ADDITIONAL SOFTWARE FEATURES—COOLING MODE

High ambient operation mode - Unit will modulate capacity down above 125 degrees outdoor temperature. The thermostat/controller display will indicate high ambient operation mode when this occurs.

High head pressure operation mode - When the unit head pressure exceeds 610 PSI, the Unit will modulate capacity pressure down until it is at or below 600 psi. Controls will indicate head pressure control mode on the display when this occurs.

Cooling Application Data 60 Hz - Outdoor Temperature — BTUH (KW) ②

Model	D.B./W.B. ①	Cooling Capacity	75°F (23.9C)	85°F (29.4C)	95°F (35.0C)	105°F (40.6C)	115°F (46.1C)	125°F (51.7C)	131°F (55C)
W3RV1 W3LV1	75 / 62F (23.9/16.7C)	Total Cooling Sensible Cooling	39,400 (11.54) 28,700 (8.41)	34,200 (10.02) 27,500 (8.06)	30,500 (8.94) 26,100 (7.65)	28,300 (8.29) 24,600 (7.21)	26,800 (7.85) 22,900 (6.71)	25,200 (7.38) 21,100 (6.18)	15,120 (4.43) 12,660 (3.71)
	80 / 67F (26.7/19.4C)	Total Cooling Sensible Cooling	42,000 (12.30) 27,800 (8.15)	37,900 (11.10) 27,200 (7.97)	35,000 (10.25) 26,300 (7.71)	33,400 (9.79) 25,200 (7.38)	32,000 (9.38) 23,800 (6.97)	30,700 (9.00) 22,200 (6.50)	18,420 (5.40) 13,320 (3.90)
	85 / 72 (29.4/22.2C)	Total Cooling Sensible Cooling	50,100 (14.68) 28,500 (8.35)	43,500 (12.75) 27,400 (8.03)	38,900 (11.40) 25,800 (7.56)	36,000 (10.55) 24,000 (7.03)	33,500 (9.82) 21,900 (6.42)	31,600 (9.26) 19,700 (5.77)	18,960 (5.56) 11,820 (3.46)
W5RV1 W5LV1	75 / 62F (23.9/16.7C)	Total Cooling Sensible Cooling	56,900 (16.67) 44,500 (13.04)	50,900 (14.91) 41,500 (12.16)	46,200 (13.54) 39,300 (11.51)	42,600 (12.48) 37,400 (10.96)	39,900 (11.69) 36,100 (10.58)	36,900 (10.81) 35,300 (10.34)	29,520 (8.65) 28,240 (8.27)
	80 / 67F (26.7/19.4C)	Total Cooling Sensible Cooling	60,700 (17.78) 43,100 (12.63)	56,500 (16.55) 41,100 (12.04)	53,000 (15.56) 39,600 (11.60)	50,200 (14.71) 38,400 (11.25)	48,000 (14.06) 37,600 (11.02)	46,500 (13.62) 37,100 (10.87)	37,200 (10.90) 29,680 (8.70)
	85 / 72 (29.4/22.2C)	Total Cooling Sensible Cooling	72,300 (21.18) 44,200 (12.95)	64,900 (19.02) 41,300 (12.10)	58,900 (17.26) 38,900 (11.40)	54,100 (15.85) 36,600 (10.72)	50,400 (14.77) 34,600 (10.14)	47,800 (14.01) 32,800 (9.61)	38,240 (11.20) 26,240 (7.69)
W6RV1 W6LV1	75 / 62F (23.9/16.7C)	Total Cooling Sensible Cooling	70,600 (20.69) 50,300 (14.74)	63,900 (18.72) 47,600 (13.95)	58,300 (17.08) 45,000 (13.18)	53,800 (15.76) 42,600 (12.48)	50,100 (14.68) 40,500 (11.87)	47,300 (13.86) 38,600 (11.30)	35,475 (10.39) 28,950 (8.48)
	80 / 67F (26.7/19.4C)	Total Cooling Sensible Cooling	75,400 (22.09) 48,800 (14.30)	71,000 (20.80) 47,100 (13.80)	67,000 (19.63) 45,400 (13.30)	63,500 (18.61) 43,700 (12.80)	60,300 (17.67) 42,100 (12.34)	57,600 (16.88) 40,600 (11.90)	43,200 (12.66) 30,450 (8.92)
	85 / 72 (29.4/22.2C)	Total Cooling Sensible Cooling	89,800 (26.31) 50,000 (14.65)	81,500 (23.88) 47,300 (13.86)	74,400 (21.80) 44,500 (13.04)	68,500 (20.07) 41,700 (12.22)	63,400 (18.58) 38,800 (11.37)	59,200 (17.35) 35,900 (10.52)	44,400 (13.01) 26,925 (7.89)

① Return air temperature at 50% R.H.

② Application data based on compressor at 100% capacity operating as CCFC up to 125°F. Above 125°F compressor capacity will modulate lower as required to stay below 610 PSIG and stay on-line.

MODELS	D.B./W.B. ①	% R.H.	Cooling Capacity	122F (50C)	131F (55C)
W3RV1 / W3LV1	85/65F (29.4/18.3C)	35	Total	27,800 (8.15)	20,600 (6.04)
			Sensible	27,800 (8.15)	20,600 (6.04)
W5RV1 / W5LV1	85/65F (29.4/18.3C)	35	Total	47,100 (13.80)	43,500 (12.75)
			Sensible	47,100 (13.80)	43,500 (12.75)
W6RV1 / W6LV1	85/65F (29.4/18.3C)	35	Total	54,700 (16.03)	51,000 (14.94)
			Sensible	54,700 (16.03)	51,000 (14.94)

③ Return air temperature at 35% R.H.

Cooling Application Data 50 Hz - Outdoor Temperature — BTUH (KW) ②

Model	D.B./W.B. ①	Cooling Capacity	75°F (23.9C)	85°F (29.4C)	95°F (35.0C)	105°F (40.6C)	115°F (46.1C)	125°F (51.7C)	131°F (55C)
W3RV1 W3LV1	75 / 62F (23.9/16.7C)	Total Cooling Sensible Cooling	35,900 (10.52) 26,200 (7.68)	31,200 (9.14) 25,100 (7.35)	27,800 (8.15) 23,800 (6.97)	25,800 (7.56) 22,400 (6.56)	25,000 (7.32) 20,900 (6.12)	23,000 (6.74) 19,300 (5.65)	13,800 (4.04) 11,580 (3.39)
	80 / 67F (26.7/19.4C)	Total Cooling Sensible Cooling	38,300 (11.22) 25,300 (7.41)	34,500 (10.11) 24,800 (7.27)	31,900 (9.35) 24,000 (7.03)	30,400 (8.91) 23,000 (6.74)	30,100 (8.82) 21,700 (6.36)	28,000 (8.20) 20,300 (5.95)	16,800 (4.92) 12,180 (3.57)
	85 / 72 (29.4/22.2C)	Total Cooling Sensible Cooling	45,600 (13.36) 26,000 (7.62)	39,600 (11.60) 25,000 (7.32)	35,400 (10.37) 23,500 (6.89)	32,800 (9.61) 21,900 (6.42)	31,600 (9.26) 20,000 (5.86)	28,800 (8.44) 18,000 (5.27)	17,280 (5.06) 10,800 (3.16)
W5RV1 W5LV1	75 / 62F (23.9/16.7C)	Total Cooling Sensible Cooling	51,800 (15.18) 40,500 (11.87)	46,400 (13.60) 37,800 (11.08)	42,100 (12.34) 35,800 (10.49)	38,800 (11.37) 34,100 (9.99)	36,400 (10.67) 32,900 (9.64)	34,800 (10.20) 32,200 (9.43)	27,840 (8.16) 25,760 (7.55)
	80 / 67F (26.7/19.4C)	Total Cooling Sensible Cooling	55,300 (16.20) 39,300 (11.51)	51,500 (15.09) 37,500 (10.99)	48,300 (14.15) 36,100 (10.58)	45,700 (13.39) 35,000 (10.25)	43,700 (12.80) 34,300 (10.05)	42,000 (12.31) 33,800 (9.90)	33,600 (9.84) 27,040 (7.92)
	85 / 72 (29.4/22.2C)	Total Cooling Sensible Cooling	65,800 (19.30) 40,300 (11.81)	59,100 (17.32) 37,600 (11.02)	53,600 (15.70) 35,400 (10.37)	49,300 (14.44) 33,400 (9.79)	45,900 (13.45) 31,500 (9.23)	43,500 (12.75) 29,900 (8.76)	34,800 (10.20) 23,920 (7.01)
W6RV1 W6LV1	75 / 62F (23.9/16.7C)	Total Cooling Sensible Cooling	64,300 (18.84) 45,800 (13.42)	58,200 (17.05) 43,400 (12.72)	53,100 (15.56) 41,000 (12.01)	49,000 (14.36) 38,800 (11.37)	45,600 (13.37) 36,900 (10.81)	43,100 (12.63) 35,200 (10.31)	32,325 (9.47) 26,400 (7.74)
	80 / 67F (26.7/19.4C)	Total Cooling Sensible Cooling	68,700 (20.13) 44,500 (13.04)	64,700 (18.96) 42,900 (12.57)	61,000 (17.87) 41,400 (12.13)	57,800 (16.94) 39,800 (11.66)	54,900 (16.09) 38,400 (11.25)	52,500 (15.38) 37,000 (10.84)	39,375 (11.54) 27,750 (8.13)
	85 / 72 (29.4/22.2C)	Total Cooling Sensible Cooling	81,800 (23.97) 45,500 (13.33)	74,200 (21.74) 43,100 (12.63)	67,800 (19.87) 40,500 (11.87)	62,400 (18.28) 38,000 (11.13)	57,700 (16.91) 35,400 (10.37)	53,900 (15.79) 32,700 (9.58)	40,425 (11.84) 24,525 (7.19)

① Return air temperature at 50% R.H.

② Application data based on compressor at 100% capacity operating as CCFC; see description page 5.

MODELS	D.B./W.B. ①	% R.H.	Cooling Capacity	122F (50C)	131F (55C)
W3RV1 / W3LV1	85/65F (29.4/18.3C)	35	Total	24,500 (7.18)	18,700 (5.48)
			Sensible	24,500 (7.18)	18,700 (5.48)
W5RV1 / W5LV1	85/65F (29.4/18.3C)	35	Total	41,900 (12.28)	39,200 (11.51)
			Sensible	41,900 (12.28)	39,200 (11.51)
W6RV1 / W6LV1	85/65F (29.4/18.3C)	35	Total	48,900 (14.33)	46,800 (13.71)
			Sensible	48,900 (14.33)	46,800 (13.71)

③ Return air temperature at 35% R.H.

Dimensions of Basic Unit for Architectural and Installation Requirements - Inches (mm)

MODEL	WIDTH (W)	DEPTH (D)	HEIGHT (H)	SUPPLY		RETURN																	
				A	B	C	B	E	F	G	I	J	K	L	M	N	O	P	Q	R	S1	S2	T
W3RV1 W3LV1	38.200 (970)	17.125 (435)	70.563 (1792)	7.88 (200)	27.88 (708)	13.88 (353)	27.88 (708)	40.00 (1016)	10.88 (276)	25.75 (654)	17.93 (455)	26.38 (670)	28.75 (730)	29.25 (743)	27.00 (686)	2.75 (70)	39.19 (996)	22.75 (578)	9.14 (232)	4.19 (106)	12.00 (305)	12.00 (305)	5.00 (127)
W5RV1 W5LV1	42.075 (1069)	22.432 (570)	84.875 (2156)	9.88 (251)	29.88 (759)	15.88 (403)	29.88 (759)	43.88 (1115)	13.56 (344)	31.66 (804)	30.00 (762)	32.31 (820)	26.94 (684)	34.69 (881)	32.43 (824)	3.37 (86)	42.88 (1089)	23.88 (607)	10.00 (254)	1.44 (37)	16.00 (406)	16.00 (406)	1.88 (48)
W6RV1 W6LV1	42.075 (1069)	22.432 (570)	94.875 (2410)	9.88 (251)	29.88 (759)	15.88 (403)	29.88 (759)	43.88 (1115)	13.56 (344)	41.66 (1056)	30.00 (762)	42.31 (1074)	36.94 (939)	44.69 (1135)	42.43 (1078)	3.37 (86)	42.88 (1089)	33.88 (861)	10.00 (254)	1.44 (37)	16.00 (406)	21.00 (533)	1.88 (48)

Dimensional drawings are not to scale.

W*RV RIGHT UNIT

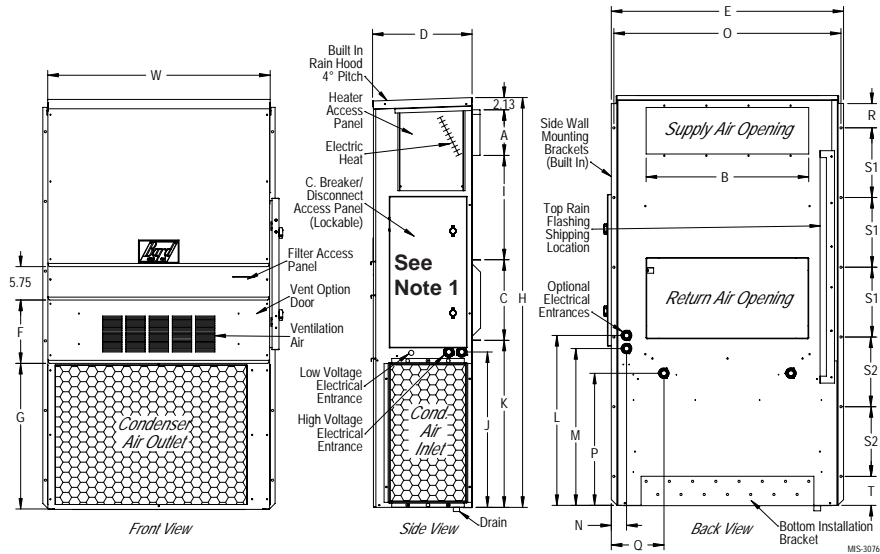

Note 1: Extreme Duty control panel door is shown and is standard. For optional flush Moderate Duty Control Panel Cover, order Control Cover option "M". See Nomenclature on Page 8.

W*LV LEFT UNIT

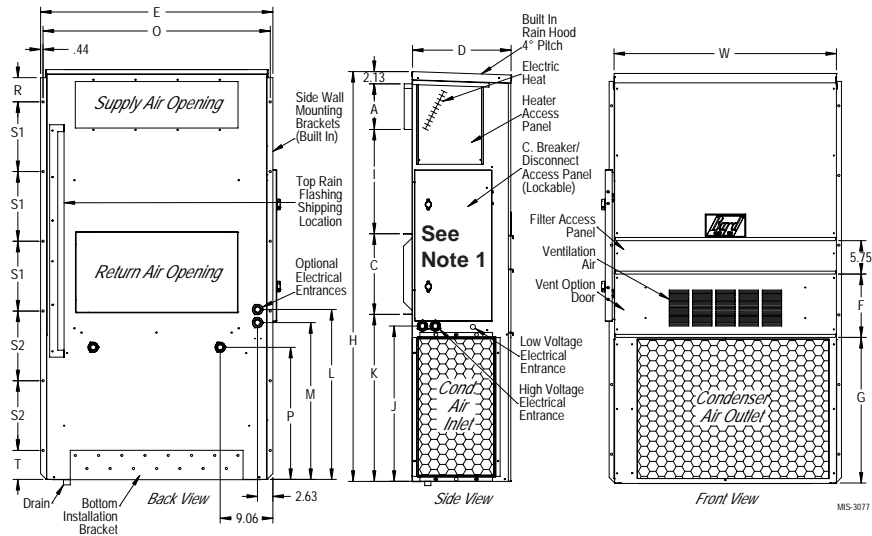

Clearances Required for Service Access and Adequate Condenser Airflow

MODELS	LEFT SIDE	RIGHT SIDE
W3RV1	15"	20"
W3LV1	20"	15"
W5RV1, W6RV1	20"	20"
W5LV1, W6LV1	20"	20"

NOTE: For side by side installation of two (2) W*RV models there must be 20" between units. This can be reduced to 15" by using a W*LV model (left side compressor and controls) for the left unit and W*R (right side compressor and controls) for right unit.

Minimum Clearances Required to Combustible Materials

MODELS	SUPPLY AIR DUCT FIRST THREE FEET	CABINET
W3R/LV1	1/4"	0"
W5R/LV1	1/4"	0"
W6R/LV1	1/4"	0"

Environmental Control Unit (ECU) Wall-Mount Model Nomenclature

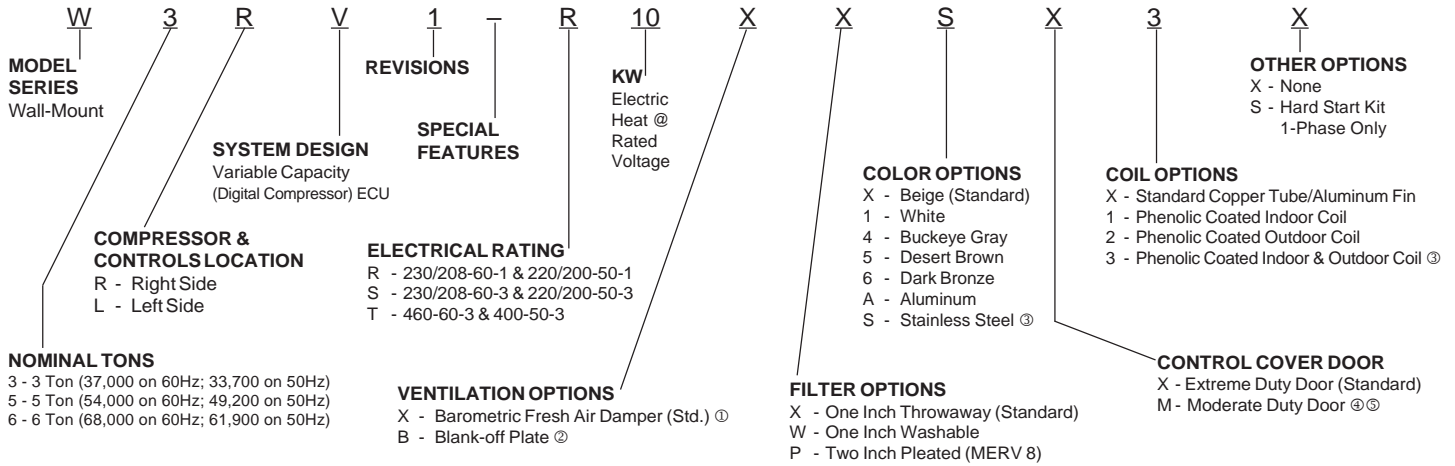

- ① Vent option X does not have exhaust capability. May require separate field supplied barometric relief in building.
- ② Blank-Off Plate recommended whenever maximum requirements against outside air intrusion are needed.
- ③ Stainless Steel cabinet and coated coils recommended for maximum durability in all harsh environments.
- ④ Moderate Duty Door not recommended for harsh environments where wind and/or very fine dust are prevalent.
- ⑤ All units equipped with flush Moderate Duty Door can be field retrofitted with the Severe Duty Door.
- Order DDD3A-color for W3R, DDD3L-color for W3L, DDD5A-color for W5R or WGR and DDD5L-color for W5L or W6L.

The following parts are unique to this product design and may not be found locally. Therefore, it is recommended that they be considered as "spares" for any mission critical installation so they would be immediately available should service ever be required. Refer to complete parts lists for more detail.

Mission Critical Components	Description	Unit Model							
		W3R/LV1-R	W3R/LV1-S	W3R/LV1-T	W5R/LV1-R	W5R/LV1-S	W5R/LV1-T	W6R/LV1-S	W6R/LV1-T
8000-355	Compressor ZPD34K5E-PFV-130	X							
8000-356	Compressor ZPD34K5E-TF5-130		X						
8000-357	Compressor ZPD34K5E-TFD-130			X					
8000-352	Compressor ZPD54K5E-PFV-130				X				
8000-360	Compressor ZPD54K5E-TF5-130					X			
8000-361	Compressor ZPD54K5E-TFD-130						X		
8000-358	Compressor ZPD72KCE-TF5-130							X	
8000-359	Compressor ZPD72KCE-TFD-130								X
S8106-047-0076	1/2 HP ECM Condenser Motor w/Programmed Control	X	X	X					
S8106-047-0080	1/2 HP ECM Condenser Motor w/Programmed Control				X	X	X	X	X
S8106-052-0075	1/2 HP ECM Blower Motor w/Programmed Control	X	X	X					
S8107-017-0079A	3/4 HP ECM Blower Motor w/Programmed Control				X	X	X	X	X
5651-214	Cooling TXV	X	X	X					
5651-215	Cooling TXV				X	X	X		
5651-213	Cooling TXV							X	X
5650-049	Solenoid Valve	X	X	X	X	X	X	X	X
1804-0462	High Pressure Switch 650# CO Flare Red Leads	X	X	X	X	X	X	X	X
1804-0386	Low Pressure Switch 32# CO 45# CI Flare Blue Leads	X	X	X	X	X	X	X	X
8408-039	Discharge Line Thermostat	X	X	X	X	X	X	X	X
8406-128	Pressure Transducer 0-700 PSI 5 VDC	X	X	X	X	X	X	X	X
8407-048	Transformer 230/208V-24V 65VA	X	X		X	X		X	
8407-050	Transformer 480V-24V 65VA			X			X		X
8401-025	Compressor Contactor 2-Pole 40A	X			X				
8401-027	Compressor Contactor 3-Pole 30A		X	X		X	X	X	X
8201-088	Compressor Control Module	X	X	X	X	X	X	X	X
8201-126	Phase Monitor		X	X		X	X	X	X
8201-124	Blower Control Board	X	X	X	X	X	X	X	X
8301-041	5 VDC Supply	X	X	X	X	X	X	X	X
8201-123	Solid State Relay	X	X	X	X	X	X	X	X
8301-014	Outdoor Air Sensor	X	X	X	X	X	X	X	X
8403-066	Thermostat Controller	X	X	X	X	X	X	X	X
SK111	Hard Start Kit ① Optional Field Installed	X			X				

① Factory standard PTCR motor starting device must be removed if optional SK111 hard start kit is field installed.



Bard Manufacturing Company, Inc.
Bryan, Ohio 43506
www.bardhvac.com

Since 1914 . . . Moving ahead, just as planned.

Due to our continuous product improvement policy,
all specifications subject to change without notice.

Form No.
S3426
December, 2013

Supersedes: S3426-813