



THE WALL-MOUNT™ STEP CAPACITY HEAT PUMPS
Integrated Part Load Value (IPLV) Efficiency Up To 15.0 BTU/WATT

GREEN REFRIGERANT
R-410A

Models: C24H to C60H
Cooling Capacities:
Heating Capacities:

Up to 11.0 EER
22,200 to 55,500 BTUH
19,200 to 51,000 BTUH

QUIET CLIMATE FLEX™ *

The Bard Wall-Mount Heat Pump is a self-contained energy efficient heating and cooling system, which is designed to offer maximum indoor comfort at a minimal cost without using valuable indoor floor space or outside ground space. This unit is the ideal product for versatile applications such as: new construction, modular offices, school modernization, and the like. Factory or field installed accessories are available to meet specific job requirements.

CH Series Special Features

ECM Indoor Blower Motor:

Features a variable speed motor providing super-high efficiency, low sound levels & soft-start capabilities. The motor is self-adjusting to provide the proper airflow rate for the staged capacity, and for higher static pressure in ducted installations without user adjustment or wiring changes.

Step Capacity Compressor:

Scroll 2-Stage Compressors are standard on all 2 to 5 ton models. Eliminates need for crankcase heater.

Double isolated floating compressor mounting system, compressor sound blanket, and discharge line muffler for reduced sound level.

Quiet Curb Options:

Various curbs are specially designed for the CH product family that reduce sound levels for school and occupied building applications.

Draw-Thru Condenser Airflow:

Condenser air is brought in from the front of the unit condenser section, and exhausted through the side grilles. This allows quiet operation, and avoids heat pump defrost water accumulation in front of the CH unit.



Model C42H shown with TCURBF3660 Wall Curb Attached
 * Quiet Curb Option must be added to obtain Quiet Climate Flex™ sound ratings.

Engineered Features

Copper Tube/Aluminum Fin Coils:

Grooved copper tubing and enhanced aluminum fins provide maximum heat transfer and high energy efficiency. Optional phenolic-coated coils are also available.

Twin Blowers:

Move air quietly. All models feature variable speed blower motors providing airflow adjustment for high and low static operation. Motor overload protection is standard on all models.

Phase Rotation Monitor:

Standard on all 3 phase scroll compressors. Protects against reverse rotation if power supply is not properly connected.

R-410A Refrigerant:

Designed with R-410A (HFC) non-ozone depleting refrigerant in compliance with the Montreal protocol and 2010 EPA requirements.

Liquid Line Filter Drier:

Standard on all units. Protects system against moisture.

Foil Faced Insulation:

Standard on all units.

Galvanized 20 Gauge Zinc Coated Cabinet:

Cleaned, rinsed, sealed and dried before the polyurethane primer is applied. The cabinet is handsomely finished with a baked on, beige textured enamel, which allows it to withstand 1000 hours of salt spray tests per ASTM B117-03. Stainless Steel cabinets available.

Electrical Components:

Are easily accessible for routine inspection and maintenance through a right side, service panel opening. Features a lockable, hinged access cover to the circuit breaker or rotary disconnect switch.

Electric Heat Strips:

Features an automatic limit and thermal cut-off safety control. Heater packages are factory or field installed for all 2 through 5 ton models. Features easy slide-in field assembly with various BTUH outputs.

Condenser Fan and Motor Shroud Assembly:

Slide out for easy access.

Filter Service Door:

Separate service door provides easy access for filter change.

One Inch, Disposable Air Filters:

Are standard equipment. Filter rack permits the addition of 2" pleated filter. Factory or field installed.

Solid State Electronic Heat Pump Control:

Provides efficient 30, 60 or 90 minute defrost cycle. A thermistor sensor, speed up terminal for service and 10 minute defrost override are standard on the electronic heat pump control.

High & Low Pressure Switches are Auto-Reset:

Standard on all units. Built-in lockout circuit resets from the room thermostat. Provides commercial quality protection to the compressor.

Five Minute Compressor Time Delay:

Short cycle protection is standard. Built into the heat pump control.

Built-in Circuit Breakers:

Standard on all electric heat versions of single (230/208 volt) and three phase (230/208 volt) equipment. Rotary disconnects are standard on three phase (460 volt) equipment. 460V circuit breaker

available as option on OKW only.

Slope Top:

Standard feature for water run-off.

Full Length Mounting Brackets:

Built into cabinet for improved appearance and easy installation. NOTE: Bottom mounting bracket included to assist in installation.

Top Rain Flashing:

Standard feature on all models.

Outdoor Coil Drain Pan:

Standard built in feature. 8620-160 Drain Connection Kit is standard (recommended for non-freezing climates only).



Intertek

Bard is an ISO 9001:2008 Certified Manufacturer

Certified Capacity and Efficiency Ratings at Full Capacity

MODELS	C24H1	C30H1	C36H1	C42H1	C48H1	C60H1
Cooling BTUH, Stage 2 (Full Capacity) ① 80/67-95	22,200	29,200	35,000	40,000	45,500	55,500
EER ①②	11.0	11.0	11.0	11.0	11.0	11.0
Rated CFM	740	900	1100	1250	1500	1650
IPLV (Integrated Stage 1 and Stage 2) ①③ 80/67-80	14.3	14.5	14.5	14.5	15.0	14.8
High Temperature 47° Heating BTUH, Stage 2 (Full Capacity)	19,200	25,600	31,000	38,500	41,500	51,000
COP ①④	3.10	3.20	3.30	3.40	3.40	3.30
Rated CFM	740	900	1100	1250	1500	1650

- ① Certified in accordance with ARI Standard 390-2003 for single package vertical units
 ② EER = Energy Efficiency Ratio - BTU/WATT efficiency
 ③ Integrated Part Load Value - BTU/WATT efficiency (combines Stage 1 & 2 performance)
 ④ COP = Coefficient of Performance - BTU/WATT efficiency

Capacity and Efficiency Ratings at Partial Capacity

MODELS	C24H1	C30H1	C36H1	C42H1	C48H1	C60H1
Cooling BTUH, Stage 1 (Partial Capacity) 80/67-80	17,700	24,000	27,000	31,400	35,800	43,000
EER @ Part Load (80/67-80) Stage 1 Cooling	14.4	14.75	14.8	14.7	15.5	14.9
Operating CFM	550	650	750	900	1000	1300
High Temperature Heating 47° BTUH, Stage 1 (Partial Capacity)	14,200	18,600	21,400	26,600	29,200	36,000
Operating CFM	550	650	750	900	1000	1300

Specifications 2-1/2 through 3 Ton

MODELS	C24H1-A	C24H1-B	---	C30H1-A	C30H1-B	C30H1-C	C36H1-A	C36H1-B	C36H1-C
Electrical Rating--60 Hz	230/208-1	230/208-3	---	230/208-1	230/208-3	460-3	230/208-1	230/208-3	460-3
Operating Voltage Range	197 - 253	197 - 253	---	197 - 253	197 - 253	414 - 506	197 - 253	197 - 253	414 - 506
Compressor--Circuit A									
Voltage	203/208	230/208	---	230/208	230/208	460	230/208	230/208	460
Rated Load Amps	7.5 / 8.4	4.2 / 4.7	---	9.7 / 11.2	7.2 / 8.3	4.2	11.8 / 13.3	9.0 / 10.1	5.0
Branch Circuit Selection Current	11.7	6.5	---	13.1	8.7	4.3	15.3	11.7	5.8
Lock Rotor Amps	58.3 / 58.3	55.4 / 55.4	---	73 / 73	58 / 58	28	83 / 83	73 / 73	38
Compressor Type	Scroll	Scroll	---	Scroll	Scroll	Scroll	Scroll	Scroll	Scroll
Fan Motor & Condenser									
Fan Motor--HP-RPM-SPD	1/5-1050-1	1/5-1050-1	---	1/5-1050-1	1/5-1050-1	1/5-1050-1	1/3-825-2	1/3-825-2	1/3-825-2
Fan Motor--Amps	1.5	1.5	---	1.5	1.5	.8	2.5	2.5	1.3
Fan--DIA/CFM	20"-1900	20"-1900	---	20"-1900	20"-1900	20"-1900	24"-2900	24"-2900	24"-2900
Blower Motor & Evap.									
Blower Motor--HP-RPM-SPD	1/3 Var.	1/3 Var.	---	1/3 Var.	1/3 Var.	1/3 Var.	1/2 Var.	1/2 Var.	1/2 Var.
Blower Motor--Amps	2.4	2.4	---	2.8	2.8	2.8	2.8	2.8	2.8
CFM w/Filter ①	740 - .10	740 - .10	---	900 - .10	900 - .10	900 - .10	1100 - .15	1100 - .15	1100 - .15
Filter Sizes (inches) STD.	16 x 30 x 1	16 x 30 x 1	---	16 x 30 x 1	16 x 30 x 1	16 x 30 x 1	20 x 30 x 1	20 x 30 x 1	20 x 30 x 1
Basic Unit Weight-LBS.									
Blank-Off Plate	380	380	---	380	380	380	475	475	475
Commercial Room Ventilator	1.0	1.0	---	1.0	1.0	1.0	1.0	1.0	1.0
Economizer	35.0	35.0	---	35.0	35.0	35.0	35.0	35.0	35.0
Energy Recovery Ventilator	45.0	45.0	---	45.0	45.0	45.0	45.0	45.0	45.0
	64.0	64.0	---	64.0	64.0	64.0	64.0	64.0	64.0

Specifications 3-1/2 through 5 Ton

MODELS	C42H1-A	C42H1-B	C42H1-C	C48H1-A	C48H1-B	C48H1-C	C60H1-A	C60H1-B	C60H1-C
Electrical Rating--60 Hz	230/208-1	230/208-3	460-3	230/208-1	230/208-3	460-3	230/208-1	230/208-3	460-3
Operating Voltage Range	197 - 253	197 - 253	414 - 506	197 - 253	197 - 253	414 - 506	197 - 253	197 - 253	414 - 506
Compressor--Circuit A									
Voltage	230/208	230/208	460	230/208	230/208	460	230/208	230/208	460
Rated Load Amps	14.0 / 15.9	11.2 / 12.7	5.6	16.8 / 19.2	11.1 / 12.7	5.8	21.4 / 23.3	13.1 / 14.2	6.2
Branch Circuit Selection Current	18.0	14.2	6.3	21.2	14.1	6.5	27.2	16.6	7.3
Lock Rotor Amps	96 / 96	88 / 88	44	104	83 / 83	41	153 / 153	110 / 110	52
Compressor Type	Scroll	Scroll	Scroll	Scroll	Scroll	Scroll	Scroll	Scroll	Scroll
Fan Motor & Condenser									
Fan Motor--HP-RPM-SPD	1/3-825-2	1/3-825-2	1/3-825-1	1/3-825-2	1/3-825-2	1/3-825-1	1/2-1025-1	1/2-1025-1	1/2-1025-1
Fan Motor--Amps	2.5	2.5	1.3	2.5	2.5	1.3	4.1	4.1	4.1
Fan--DIA/CFM	24"-2900	24"-2900	24"-2900	24"-2900	24"-2900	24"-2900	24"-3700	24"-3700	24"-3700
Blower Motor & Evap.									
Blower Motor--HP-RPM-SPD	3/4 Var.	3/4 Var.	3/4 Var.	3/4 Var.	3/4 Var.	3/4 Var.	3/4 Var.	3/4 Var.	3/4 Var.
Blower Motor--Amps	3.8	3.8	3.8	4.4	4.4	4.4	4.7	4.7	4.7
CFM w/Filter ①	1250 - .15	1250 - .15	1250 - .15	1550 - .2	1550 - .2	1550 - .2	1650 - .2	1650 - .2	1650 - .2
Filter Sizes (inches) STD.	20 x 30 x 1	20 x 30 x 1	20 x 30 x 1	20 x 30 x 1	20 x 30 x 1	20 x 30 x 1	20 x 30 x 1	20 x 30 x 1	20 x 30 x 1
Basic Unit Weight-LBS.									
Blank-Off Plate	520	520	540	550	550	595	555	555	600
Commercial Room Ventilator	1.0	1.0	1.0	1.0	1.0	1.0	1.0	1.0	1.0
Economizer	35.0	35.0	35.0	35.0	35.0	35.0	35.0	35.0	35.0
Energy Recovery Ventilator	45.0	45.0	45.0	45.0	45.0	45.0	45.0	45.0	45.0
	81.0	81.0	81.0	81.0	81.0	81.0	81.0	81.0	81.0

Ventilation System Packages

Bard Wall-Mounts are designed to provide optional ventilation packages to meet all of your ventilation and indoor air quality requirements. All units are equipped with a barometric fresh air damper as the standard ventilation package. All ventilation packages can be built-in at the factory, or field-installed at a later date.

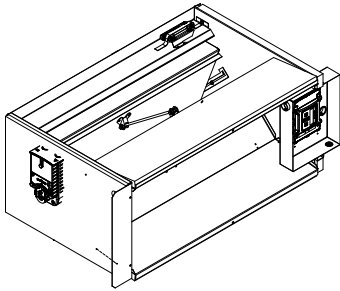

Commercial Room Ventilator

BLANK OFF PLATE - BOP

OPTIONAL

A blank off plate is installed on the inside of the service door. It covers the air inlet openings which restricts any outside air from entering into the unit. The blank off plate should be utilized in applications where outside air is not required to be mixed with the conditioned air.

COMMERCIAL ROOM VENTILATOR - CHCRV

OPTIONAL

NOTE: Models C24H & C30H with CHCRV-3 require a Wall Curb Model TCURBF2430 or TCURBT2430 (See Page 10)

The built-in commercial room ventilator is internally mounted behind the service door and allows outside ventilation air, up to 50% of the total airflow rating of the unit, to be introduced through the air inlet openings. It includes a built-in exhaust air damper.

The commercial room ventilator (CRV) is a simple and innovative approach to improving the indoor air quality by providing fresh air intake and exhaust capability through the CRV. The damper can be easily adjusted to control the amount of fresh air supplied into the building. The CRV can be controlled by indoor blower operation or field controlled based on room occupancy. The CRV is modulating design with power open - spring return on power loss. Complies with ANSI/ASHRAE Standard 62.1 "Ventilation for Acceptable Indoor Air Quality."

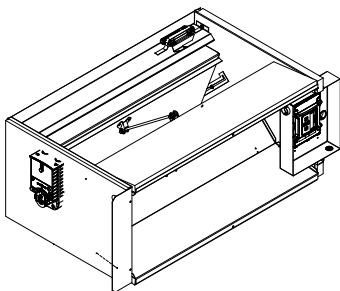

Economizer

ECONOMIZER - ECONCHS

OPTIONAL

All economizers require matching TCURBF or TCURBT (See Page 10)

The built-in economizer system is internally mounted behind the service door and allows outdoor air to be introduced through the air inlet openings. The amount of outdoor air varies in response to the system controls and settings defined by the end user. It includes a built-in exhaust air damper. The economizer is designed to provide "free cooling" when outside air conditions are cool and dry enough to satisfy cooling requirements without running the compressor. This in turn provides lower operating costs, while extending the life of the compressor.

Standard Features:

- Designed to deliver 75% of cooling rated CFM when equipped with standard 3" air intake hood
- Honeywell Direct Drive Hi-Torque Actuator
- Positive shut-off with non-stick gaskets
- Electronic sensors, Enthalpy used for outdoor free cooling decision
- Honeywell JADE electronic economizer module with precision settings and diagnostics

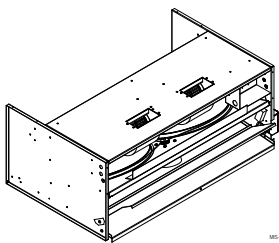

Energy Recovery Ventilator

WALL-MOUNT ENERGY RECOVERY VENTILATOR - CHERV

OPTIONAL

The wall-mount energy recovery ventilator (ERV) is a highly innovative approach to meeting indoor air quality ventilation requirements as established by ANSI/ASHRAE Standard 62.1. The ERV allows from 200 to 450 CFM (depending upon model) of fresh air and exhaust through the unit while maintaining superior indoor comfort and humidity levels. In most cases this can be accomplished without increasing equipment sizing or operating costs. Heat transfer efficiency is up to 67% during summer and 75% during winter conditions.

The ERV consists of a unique "rotary energy recovery cassette" that provides effective sensible and latent heat transfer capabilities during summer and winter conditions. Various control schemes are addressed including limiting ventilation during building occupancy only.

The ERV is designed to be internally mounted behind the service door in the WA, WH or WL model wall-mount units. It can be built-in at the factory or field installed as an option. CHERV-*3 and CHERV-*5 can be independently adjusted for intake and exhaust rates. 3" air intake hood is standard.

CHERV Model ERV's have exhaust gravity shut-off dampers all sizes. CHERV-A5 & -C5 have motorized air intake damper.

DRAW-THRU CONDENSER AIRFLOW

The CH unit requires the use of a curb to meet the Quietflex sound ratings. Due to draw-thru air pressurizing the condenser section, room exhaust air exits the bottom of the curb. These special wall curbs allow for the exhaust air to pass through the bottom of the curb instead of through the condenser section of the CH unit.

The following vent options require the use of a wall curb:

- CHCRV-3
- ECONCHS-E3
- ECONCHS-E5

Refer to the "C**H Unit to Wall Curb Application Guide" (Page 10) for curb selection options when using the vent options listed above.

- Complies with efficiency requirements of ASHRAE/IESNA 90.1-2013.
- Certified to ANSI/ARI Standard 390-2003 for SPVU (Single Package Vertical Units).
- Intertek ETL Listed to Standard for Safety Heating and Cooling Equipment ANSI/UL 1995/CSA 22.2 No. 236-05, Fourth Edition.
- Commercial Product - Not intended for Residential application.

Modulating Commercial Room Ventilator Performance Data : CHCRV-3 for C24H

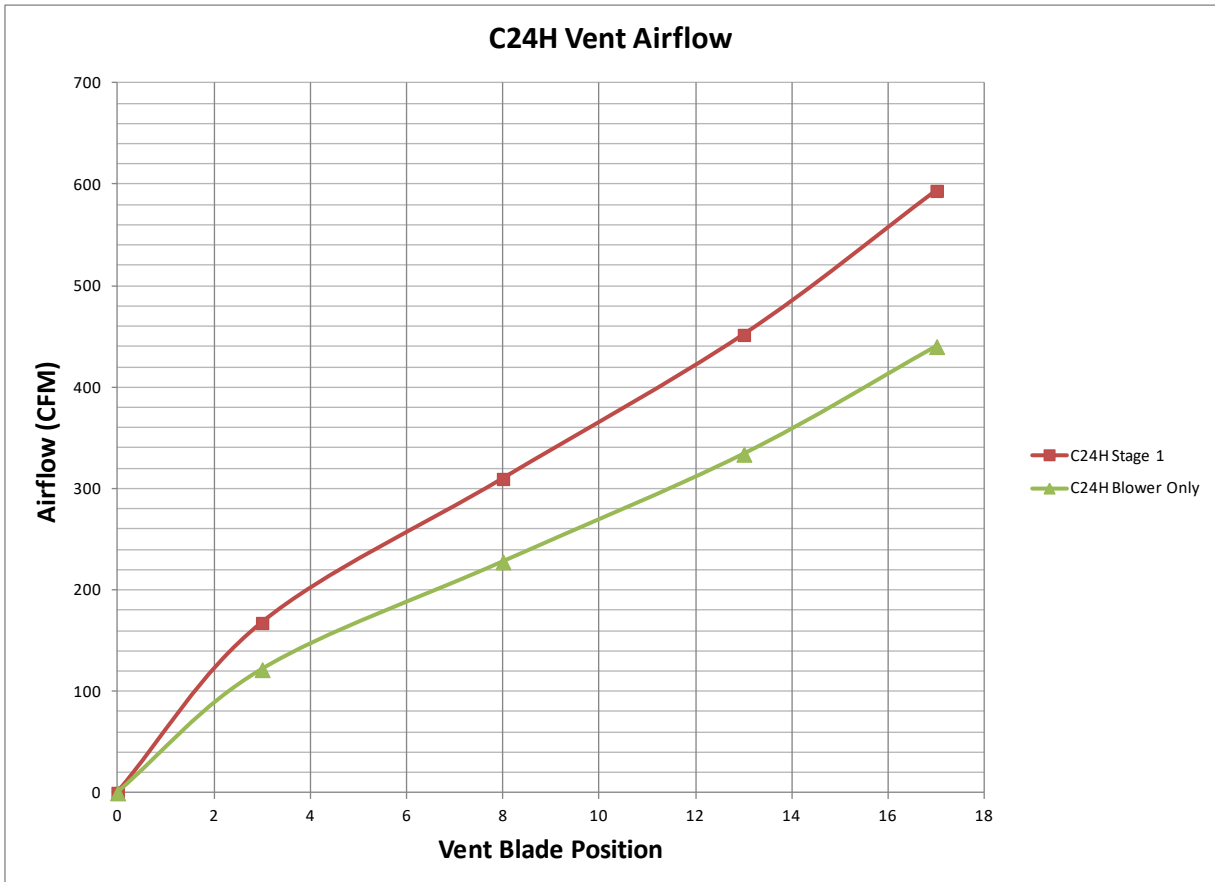

Airflow amounts less than 100 CFM may not be achievable.

Modulating Commercial Room Ventilator Performance Data : CHCRV-3 for C30H

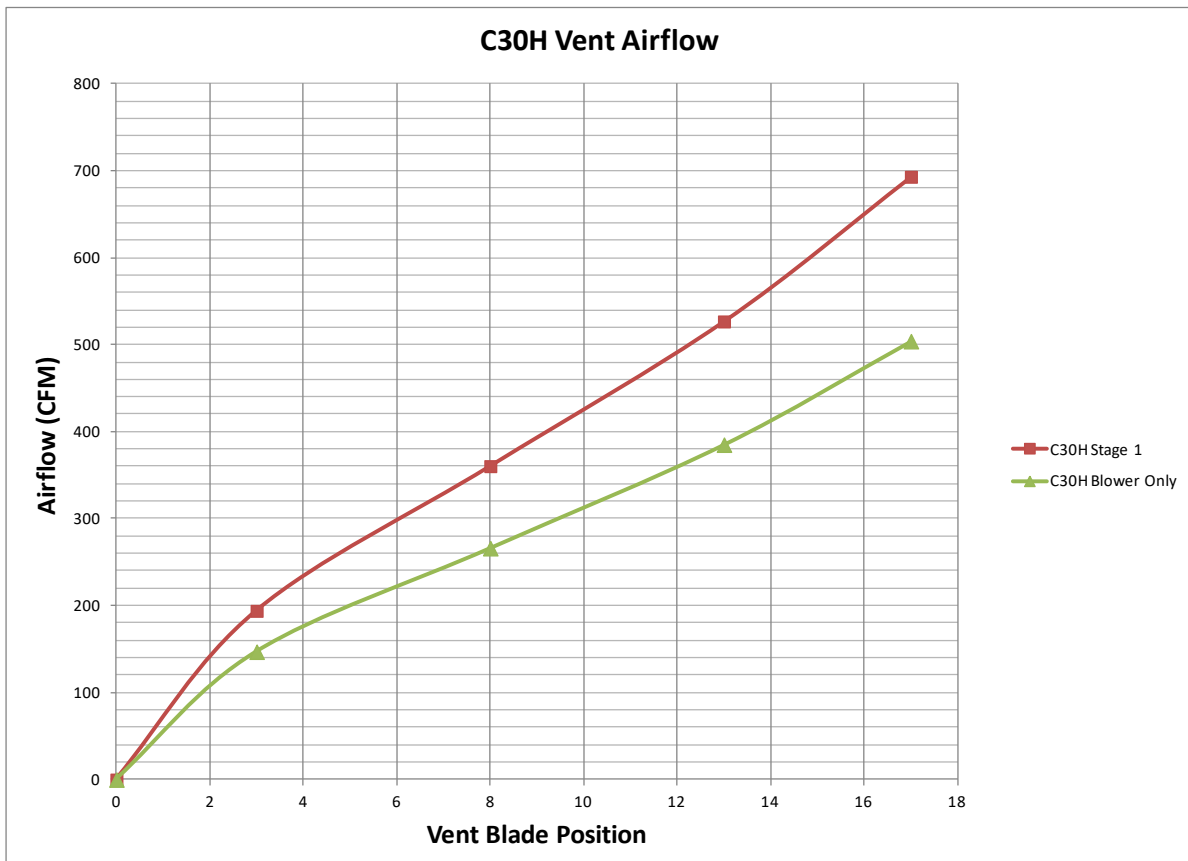

Airflow amounts less than 100 CFM may not be achievable.

Commercial Room Ventilator Performance Data : CHCRV-5 for C36H & C42H

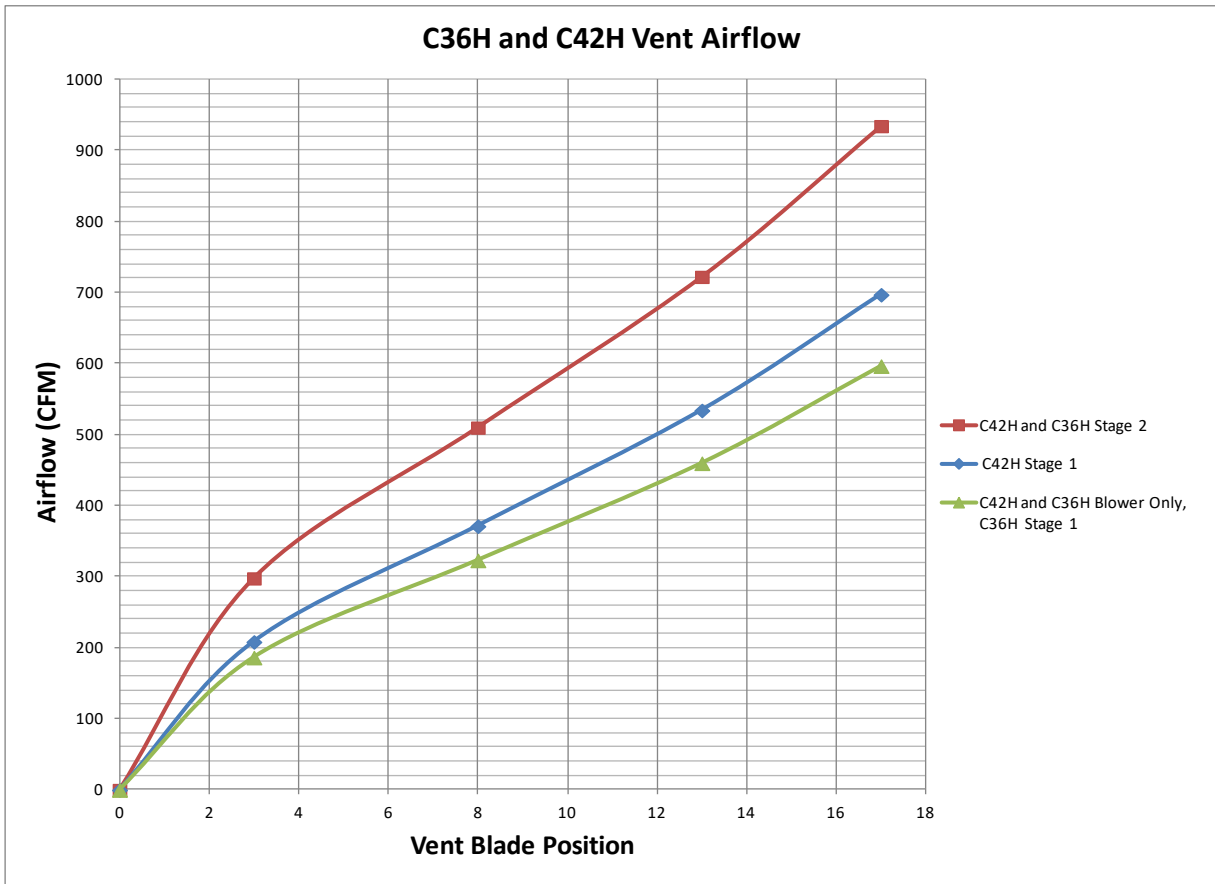

Airflow amounts less than 100 CFM may not be achievable.

Commercial Room Ventilator Performance Data : CHCRV-5 for C48H & C60H

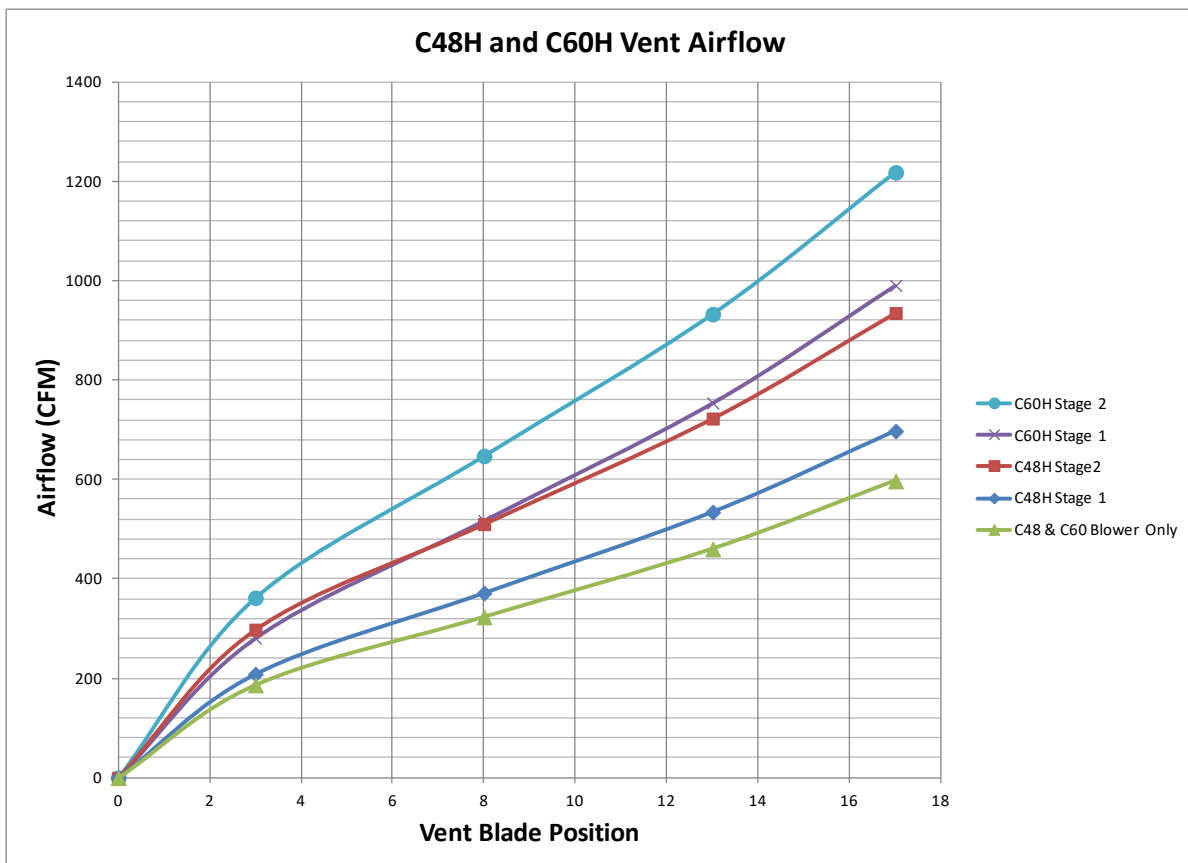

Airflow amounts less than 100 CFM may not be achievable.

This page intentionally left blank

Performance and Application Data - CHERV-*3 (C24H1 & C30H1)

SUMMER COOLING PERFORMANCE (INDOOR DESIGN CONDITIONS 75°DB / 62°WB)

Ambient O.D.	VENTILATION RATE 400 CFM 63% EFFICIENCY						VENTILATION RATE 325 CFM 64% EFFICIENCY						VENTILATION RATE 250 CFM 65% EFFICIENCY						
	DB/ WB	F	VLT	VLS	VLL	HRT	HRS	HRL	VLT	VLS	VLL	HRT	HRS	HRL	VLT	VLS	VLL	HRT	HRS
105	75	19080	12960	6120	12020	8164	3855	15502	10530	4972	9921	6739	3182	11925	8100	3825	7751	5265	2486
	70	12960	12960	0	8164	8164	0	10530	10530	0	6739	6739	0	8100	8100	0	5265	5265	0
	65	12960	12960	0	8164	8164	0	10530	10530	0	6739	6739	0	8100	8100	0	5265	5265	0
100	80	28080	10800	17280	17690	6804	10886	22815	8775	14040	14601	5616	8985	17550	6750	10800	11407	4387	7019
	75	19080	10800	8280	12020	6804	5216	15502	8775	6727	9921	5616	4305	11925	6750	5175	7751	4387	3363
	70	10980	10800	180	6717	6804	113	8921	8775	146	5709	5616	93	6862	6750	112	4460	4387	73
	65	10800	10800	0	6804	6804	0	8775	8775	0	5616	5616	0	6750	6750	0	4387	4387	0
	60	10800	10800	0	6804	6804	0	8775	8775	0	5616	5616	0	6750	6750	0	4387	4387	0
95	80	28080	8640	19440	17690	5443	12247	22815	7020	15795	14601	4492	10108	17550	5400	12150	11407	3510	7897
	75	19080	8640	10440	12020	5443	6577	15502	7020	8482	9921	4492	5428	11925	5400	6525	7751	3510	4241
	70	10980	8640	2340	6917	5443	1474	8921	7020	1901	5709	4492	1216	6862	5400	1462	4460	3510	950
	65	8640	8640	0	5443	5443	0	7020	7020	0	4492	4492	0	5400	5400	0	3510	3510	0
	60	8640	8640	0	5443	5443	0	7020	7020	0	4492	4492	0	5400	5400	0	3510	3510	0
90	80	28080	6480	21600	17690	4082	13608	22815	5265	17550	14601	3369	11232	17550	4050	13500	11407	2632	8774
	75	19080	6480	12600	12020	4082	7938	15502	5265	10237	9921	3369	6552	11925	4050	7875	7751	2632	5118
	70	10980	6480	4500	6917	4082	2835	8921	5265	3656	5709	3369	2340	6862	4050	2812	4460	2632	1828
	65	6480	6480	0	4082	4082	0	5265	5265	0	3369	3369	0	4050	4050	0	2632	2632	0
	60	6480	6480	0	4082	4082	0	5265	5265	0	3369	3369	0	4050	4050	0	2632	2632	0
85	80	28080	4320	23760	17690	2721	14968	22815	3510	19305	14601	2246	12355	17550	2700	14850	11407	1755	9652
	75	19080	4320	14760	12020	2721	9298	15502	3510	11992	9921	2246	7675	11925	2700	9225	7751	1755	5996
	70	10980	4320	6660	6917	2721	4195	8921	3510	5411	5709	2246	3463	6862	2700	4162	4460	1755	2705
	65	4320	4320	0	2721	2721	0	3510	3510	0	2246	2246	0	2700	2700	0	1755	1755	0
	60	4320	4320	0	2721	2721	0	3510	3510	0	2246	2246	0	2700	2700	0	1755	1755	0
80	75	19080	2160	16920	12020	1360	10659	15502	1755	13747	9921	1123	8798	11925	1350	10575	7751	877	6873
	70	10980	2160	8820	6917	1360	5556	8921	1755	7166	5709	1123	4586	6862	1350	5512	4460	877	3583
	65	3780	2160	1620	2381	1360	1020	3071	1755	1316	1965	1123	842	2362	1350	1012	1535	877	658
	60	2160	2160	0	1360	1360	0	1755	1755	0	1123	1123	0	1350	1350	0	877	877	0
75	70	10980	0	10980	6917	0	6917	8921	0	8921	5709	0	5709	6862	0	6862	4460	0	4460
	65	3780	0	3780	2381	0	2380	3071	0	3071	1965	0	1965	2362	0	2362	1535	0	1535
	60	0	0	0	0	0	0	0	0	0	0	0	0	0	0	0	0	0	0

CHERV-*3 WINTER HEATING PERFORMANCE (INDOOR DESIGN CONDITIONS 70°DB)

Ambient O.D.	VENTILATION RATE					
	400 CFM 75% EFF.		325 CFM 76% EFF.		250 CFM 77% EFF.	
DB/°F	WVL	WHR	WVL	WHR	WVL	WHR
65	2160	1620	1755	1333	1350	1039
60	4320	3240	3510	2667	2700	2079
55	6480	4860	5265	4001	4050	3118
50	8640	6480	7020	5335	5400	4158
45	10800	8100	8775	6669	6750	5197
40	12960	9720	10530	8002	8100	6237
35	15120	11340	12285	9336	9450	7276
30	17280	12960	14040	10670	10800	8316
25	19440	14580	15795	12004	12150	9355
20	21600	16200	17550	13338	13500	10395
15	23760	17820	19305	14671	14850	11434

LEGEND:

VLT = Ventilation Load - Total
VLS = Ventilation Load - Sensible
VLL = Ventilation Load - Latent
HRT = Heat Recovery - Total
HRS = Heat Recovery - Sensible
HRL = Heat Recovery - Latent
WVL = Winter Ventilation Load
WHR = Winter Heat Recovery

NOTE: Sensible performance only is shown for winter application.

Performance and Application Data - CHERV-*5 (C36H1, C42H1, C48H1 & C60H1)

SUMMER COOLING PERFORMANCE (INDOOR DESIGN CONDITIONS 75°DB / 62°WB)

Ambient O.D.		VENTILATION RATE 450 CFM						VENTILATION RATE 375 CFM						VENTILATION RATE 300 CFM					
DB/ WB	F	VLT	VLS	VLL	HRT	HRS	HRL	VLT	VLS	VLL	HRT	HRS	HRL	VLT	VLS	VLL	HRT	HRS	HRL
105	75	21465	14580	6884	13952	9477	4475	17887	12150	5737	11805	8018	3786	14310	9720	4590	9587	6512	3075
	70	14580	14580	0	9477	9477	0	12150	12150	0	8018	8018	0	9720	9720	0	6512	6512	0
	65	14580	14580	0	9477	9477	0	12150	12150	0	8018	8018	0	9720	9720	0	6512	6512	0
100	80	31590	12150	19440	20533	7897	12635	26325	10125	16200	17374	6682	10692	21060	8100	12960	14110	5427	8683
	75	21465	12150	9314	13952	7897	6054	17887	10125	7762	11805	6682	5123	14310	8100	6210	9587	5427	4160
	70	12352	12150	202	8029	7897	131	10293	10125	168	6793	6682	111	8235	8100	135	5517	5427	90
	65	12150	12150	0	7897	7897	0	10125	10125	0	6682	6682	0	8100	8100	0	5427	5427	0
	60	12150	12150	0	7897	7897	0	10125	10125	0	6682	6682	0	8100	8100	0	5427	5427	0
95	80	31590	9720	21870	20533	6318	14215	26325	8100	18225	17374	5345	12028	21060	6480	14580	14110	4341	9768
	75	21465	9720	11744	13952	6318	7634	17887	8100	9787	11805	5345	6459	14310	6480	7830	9587	4341	5246
	70	12352	9720	2632	8029	6318	1711	10293	8100	2193	6793	5345	1447	8235	6480	1755	5517	4341	1175
	65	9720	9720	0	6318	6318	0	8100	8100	0	5345	5345	0	6480	6480	0	4341	4341	0
	60	9720	9720	0	6318	6318	0	8100	8100	0	5345	5345	0	6480	6480	0	4341	4341	0
90	80	31590	7290	24300	20533	4738	15794	26325	6075	20250	17374	4009	13365	21060	4860	16200	14110	3256	10854
	75	21465	7290	14175	13952	4738	9213	17887	6075	11812	11805	4009	7796	14310	4860	9450	9587	3256	6331
	70	12352	7290	5062	8029	4738	3290	10293	6075	4218	6793	4009	2784	8235	4860	3375	5517	3256	2261
	65	7290	7290	0	4738	4738	0	6075	6075	0	4009	4009	0	4860	4860	0	3256	3256	0
	60	7290	7290	0	4738	4738	0	6075	6075	0	4009	4009	0	4860	4860	0	3256	3256	0
85	80	31590	4860	26730	20533	3159	17374	26325	4050	22275	17374	2672	14701	21060	3240	17820	14110	2170	11939
	75	21465	4860	16605	13952	3159	10793	17887	4050	13837	11805	2672	9132	14310	3240	11070	9587	2170	7416
	70	12352	4860	7492	8029	3159	4870	10293	4050	6243	6793	2672	4120	8235	3240	4995	5517	2170	3346
	65	4860	4860	0	3159	3159	0	4050	4050	0	2672	2672	0	3240	3240	0	2170	2170	0
	60	4860	4860	0	3159	3159	0	4050	4050	0	2672	2672	0	3240	3240	0	2170	2170	0
80	75	21465	2430	19035	13952	1579	12372	17887	2025	15862	11805	1336	10469	14310	1620	12690	9587	1085	8502
	70	12352	2430	9922	8029	1579	6449	10293	2025	8268	6793	1336	5457	8235	1620	6615	5517	1085	4432
	65	4252	2430	1822	2764	1579	1184	3543	2025	1518	2338	1336	1002	2835	1620	1215	1899	1085	814
	60	2430	2430	0	1579	1579	0	2025	2025	0	1336	1336	0	1620	1620	0	1085	1085	0
75	70	12352	0	12352	8029	0	8029	10293	0	10293	6793	0	6793	8235	0	8235	5517	0	5517
	65	4252	0	4252	2764	0	2764	3543	0	3543	2338	0	2338	2835	0	2835	1899	0	1899
	60	0	0	0	0	0	0	0	0	0	0	0	0	0	0	0	0	0	0

CHERV-*5 WINTER HEATING PERFORMANCE (INDOOR DESIGN CONDITIONS 70°DB)

Ambient O.D.	VENTILATION RATE					
	450 CFM		375 CFM		300 CFM	
DB/°F	WVL	WHR	WVL	WHR	WVL	WHR
65	2430	1944	2025	1640	1620	1328
60	4860	3888	4050	3280	3240	2656
55	7290	5832	6075	4920	4860	3985
50	9720	7776	8100	6561	6480	5313
45	12150	9720	10125	8201	8100	6642
40	14580	11664	12150	9841	9720	7970
35	17010	13608	14175	11481	11340	9298
30	19440	15552	16200	13122	12960	10627
25	21870	17496	18225	14762	14580	11955
20	24300	19440	20250	16402	16200	13284
15	26730	21384	22275	18042	17820	14612

LEGEND:

- VLT = Ventilation Load - Total
- VLS = Ventilation Load - Sensible
- VLL = Ventilation Load - Latent
- HRT = Heat Recovery - Total
- HRS = Heat Recovery - Sensible
- HRL = Heat Recovery - Latent
- WVL = Winter Ventilation Load
- WHR = Winter Heat Recovery

NOTE: Sensible performance only is shown for winter application.

Electrical Specifications — Standard Heat Pumps

Model	Rated Volts & Phase	No. Field Power Circuits	Single Circuit				Multiple Circuit														
			① Minimum Circuit Ampacity	② Max. External Fuse or Ckt. Brkr.	③ Field Power Wire Size	④ Ground Wire	⑤ Minimum Circuit Ampacity			⑥ Max. Circuit Exterior Fuse or Ckt. Brkr.			⑦ Field Power Wire Size			⑧ Ground Wire					
							Ckt. A	Ckt. B	Ckt. C	Ckt. A	Ckt. B	Ckt. C	Ckt. A	Ckt. B	Ckt. C	Ckt. A	Ckt. B	Ckt. C			
C24H1-A0Z -A04 Ⓞ -AS8 Ⓞ -AF8	230/208-60-1	1	22	30	10	10															
		1	42	50	8	10															
		1 or 2	48	50	8	10															
		1	63	70	6	8	22	42				30	45			10	8			10	10
C24H1-B0Z -B06 -B09	230/208-60-3	1	15	20	12	12															
		1	33	35	8	10															
		1	42	45	8	10															
C30H1-A0Z -A04 Ⓞ -AS8 Ⓞ -AF8	230/208-60-1	1	23	30	10	10															
		1	44	50	8	10															
		1	49	50	8	10															
		1 or 2	65	70	6	8	23	42				30	45			10	8			10	10
C30H1-B0Z -B06 -B09	230/208-60-3	1	18	25	10	10															
		1	36	40	8	10															
		1	45	45	8	10															
NOTE A C30H1-C0Z/C0C -C06 -C09	460-60-3	1	10	15	14	14															
		1	19	20	12	12															
		1	24	25	10	10															
C36H1-A0Z -A05 -A10 Ⓞ -A15	230/208-60-1	1	27	40	8	10															
		1	53	60	6	10															
		1 or 2	79	80	4	8	27	52				40	60			8	6			10	10
		1 or 2	85	90	4	8	33	52			40	60			8	6			10	10	
C36H1-B0Z -B06 -B09 Ⓞ -B15	230/208-60-3	1	23	30	10	10															
		1	41	45	8	10															
		1	50	50	8	10															
		1	52	60	6	10															
NOTE A C36H1-C0Z/C0C -C06 -C09 Ⓞ -C15	460-60-3	1	12	15	14	14															
		1	21	25	10	10															
		1	26	30	10	10															
		1	27	30	10	10															
C42H1-A0Z -A05 -A10 Ⓞ -A15	230/208-60-1	1	31	40	8	10															
		1	57	60	6	10															
		1 or 2	83	90	4	8	31	52				40	60			8	6			10	10
		1 or 2	86	90	3	8	34	52			40	60			8	6			10	10	
C42H1-B0Z -B06 -B09 Ⓞ -B15	230/208-60-3	1	27	35	8	10															
		1	45	50	8	10															
		1	54	60	6	10															
		1	54	60	6	10															
NOTE A C42H1-C0Z/C0C -C06 -C09 Ⓞ -C15	460-60-3	1	13	15	14	14															
		1	22	25	10	10															
		1	26	30	10	10															
		1	27	30	10	10															
C48H1-A0Z -A04 -A05 -A10 Ⓞ -A15 Ⓞ -A20	230/208-60-1	1	37	50	8	10															
		1	57	60	6	10															
		1	62	70	6	8	37	26			50	30			8	10			10	10	
		1 or 2	88	90	3	8	37	52			50	60			8	6			10	10	
		1 or 2	88	90	3	8	37	52			50	60			8	6			10	10	
		1 or 3	113	125	2	6	37	52	26		50	60	30		8	6	10		10	10	
C48H1-B0Z -B06 -B09 Ⓞ -B15 Ⓞ -B18	230/208-60-3	1	27	40	8	10															
		1	45	50	8	10															
		1	54	60	6	10															
		1	54	60	6	10															
		2	N/A	N/A	N/A	N/A	54	28			60	30			6	10			10	10	
NOTE A C48H1-C0Z/C0C -C06 -C09 Ⓞ -C15	460-60-3	1	13	20	12	12															
		1	22	25	10	10															
		1	27	30	10	10															
		1	27	30	10	10															
C60H1-A0Z -A05 -A10 Ⓞ -A15 Ⓞ -A20	230/208-60-1	1	45	60	8	10															
		1 or 2	71	80	4	8	45	26			50	30			8	10			10	10	
		1 or 2	97	100	3	8	45	52			50	60			8	6			10	10	
		1 or 2	97	100	3	8	45	52			50	60			8	6			10	10	
		1 or 3	113	125	2	6	45	52	26		50	60	30		8	6	10		10	10	
C60H1-B0Z -B06 -B09 Ⓞ -B15 Ⓞ -B18	230/208-60-3	1	32	45	8	10															
		1	50	60	8	10															
		1	59	60	6	10															
		1	59	60	6	10															
		2	N/A	N/A	N/A	N/A	59	28			60	30			6	10			10	10	
NOTE A C60H1-C0Z/C0C -C06 -C09 Ⓞ -C15	460-60-3	1	17	20	12	12															
		1	26	30	10	10															
		1	31	35	8	10															
		1	31	35	8	10															

① These "Minimum Circuit Ampacity" values are to be used for sizing the field power conductors. Refer to the National Electrical Code (latest version), Article 310 for power conductor sizing.
Caution: When more than one field power circuit is run through one conduit, the conductors must be derated. Pay special attention to note 8 of Table 310 regarding Ampacity Adjustment Factors when more than three (3) conductors are in a raceway.
 ② Maximum size of the time delay fuse or HACR type circuit breaker for protection of field wiring conductors.
 ③ Based on 75°C copper wire. All wiring must conform to the National Electrical Code and all local codes.
 ④ Maximum KW that can operate with the heat pump on is 4KW. Full heat available during Emergency Heat Mode.
 ⑤ Maximum KW that can operate with the heat pump on is 10KW. Full heat available during Emergency Heat Mode.
 ⑥ Maximum KW that can operate with the heat pump on is 9KW. Full heat available during Emergency Heat Mode.
 ⑦ Maximum KW that can operate with the heat pump on is 8KW. Full heat available during Emergency Heat Mode.
IMPORTANT: While this electrical data is presented as a guide, it is important to electrically connect properly sized fuses & conductor wires in accordance with the National Electrical Code & all local codes.
NOTE A: -C Models have Rotary Disconnect. COC 460V circuit breaker only available for 0KW. All electrical ratings are the same.

NOTE: To obtain Quiet Climate Flex™ sound ratings, a TCURB Model Fig. 1 to Fig. 6 must be used.

CH Unit to Wall Curb Application Guide**

Fig. No.	Curb Model ①②	Application	Curb Depth	Curb Height	Used with Unit Model(s)	Unit Indoor Air Connections				Curb Indoor Air Connections				Shipping Weight Lbs.
						Supply Air H x W	Return Air H x W	Spacing SA to RA	Supply Air H x W	Return Air H x W	Spacing SA to RA	Alt. Spacing SA to RA		
1	TCURBF2430A		9.313	70-5/16	C24H, C30H	7.88 x 27.88	13.88 x 27.88	17.93	7.88 x 27.88	13.88 x 27.88	6.125	17.93	160	
2	TCURBF3642A	Used to direct replace CH3S Models.	9.313	85%	C36H, C42H	9.88 x 29.88	15.88 x 29.88	30.00	9.88 x 29.88	15.88 x 29.88	6.125	30.00	195	
3	TCURBF4860A	Used to direct replace CH4S and CH5S Models.	9.313	85-5/16	C48H, C60H	9.88 x 29.88	15.88 x 29.88	30.00	9.88 x 29.88	15.88 x 29.88	6.125	30.00	195	
4	TCURBT2430A	Used to install 2 or 2.5-ton cabinet machines installed in a soffit.	9.313	82¼	C24H, C30H	7.88 x 27.88	13.88 x 27.88	17.93	7.88 x 27.88	13.88 x 27.88	17.93		170	
5	TCURBT3642A	Used to install 3 or 3.5-ton cabinet machines installed in a soffit.	9.313	109¼	C36H, C42H	9.88 x 29.88	15.88 x 29.88	30.00	9.88 x 29.88	15.88 x 29.88	30.00		235	
6	TCURBT4860A	Used to install 4 or 5-ton cabinet machines installed in a soffit.	9.313	109¼	C48H, C60H	9.88 x 29.88	15.88 x 29.88	30.00	9.88 x 29.88	15.88 x 29.88	30.00		225	
7	WMICF3A	Isolation Curb	3.625	70%	C24H, C30H	7.88 x 27.88	13.88 x 27.88	17.93	7.88 x 27.88	13.88 x 27.88	17.93		110	
8	WMICF5A	Isolation Curb	3.625	84%	C36H, C42H	9.88 x 29.88	15.88 x 29.88	30.00	9.88 x 29.88	15.88 x 29.88	30.00		130	
9	WMICF5A	Isolation Curb	3.625	84%	C48H, C60H	9.88 x 29.88	15.88 x 29.88	30.00	9.88 x 29.88	15.88 x 29.88	30.00		130	
10	TFCT-32A	Used to install new 2-ton in place of old 2-ton in a soffit.	9.313	80¼	C24H, C30H	7.88 x 27.88	13.88 x 27.88	17.93	7.88 x 19.88	11.88 x 19.88	20.56		175	
11	TFCT-53A	Used to install new 3-ton in place of old 3-ton in a soffit.	9.313	82¼	C36H, C42H	9.88 x 29.88	15.88 x 29.88	30.00	7.88 x 27.88	13.88 x 27.88	17.93		185	
12	TFCF-32A	Used to install new 2-ton in place of old 2-ton.	9.313	70%	C24H, C30H	7.88 x 27.88	13.88 x 27.88	17.93	7.88 x 19.88	11.88 x 19.88	20.56		160	
13	TFCF-53A	Used to install new 3-ton in place of old 3-ton.	9.313	70%	C36H, C42H	9.88 x 29.88	15.88 x 29.88	30.00	7.88 x 27.88	13.88 x 27.88	17.93		170	
14	WMRSC3SA	Used to install new 3-ton where there are obstacles (conduit, etc) underneath original unit.	9.313	72	C36H	9.88 x 29.88	15.88 x 29.88	30.00	7.88 x 27.88	13.88 x 27.88	17.93		170	

SEE NOTE A

① All curb model numbers followed by -X (beige), -4 (gray), etc to match unit color.

② All curbs have 4 rubber isolation mounts to reduce vibration to the installation wall.

NOTE A: For all economizer applications a TCURB***** is required. For C24 & C30 installations with CHCRV-3 a TCURB is also required.

All Dimensions in Inches.

FIG. 1
TCURBF2430A

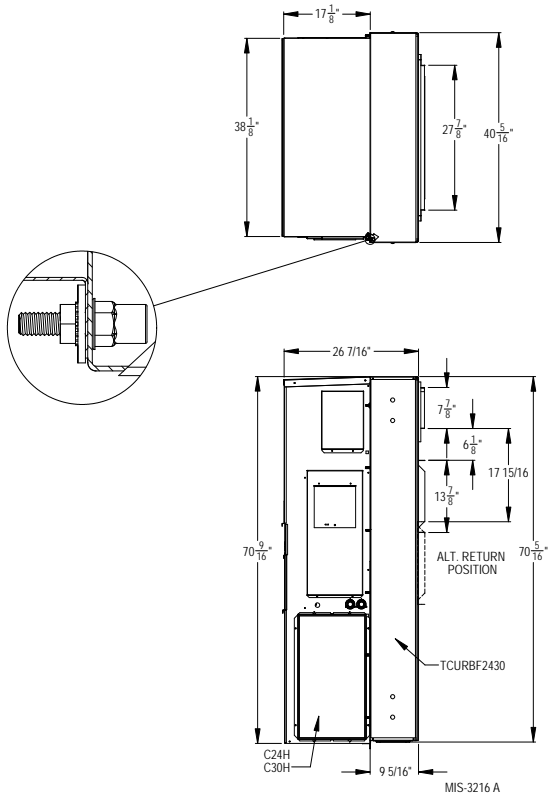

FIG. 2
TCURBF3642A

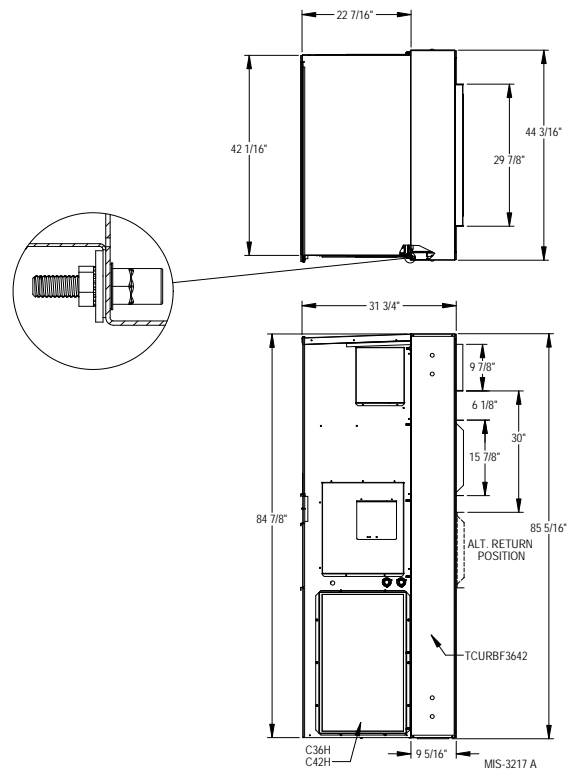

FIG. 3
TCURBF4860A

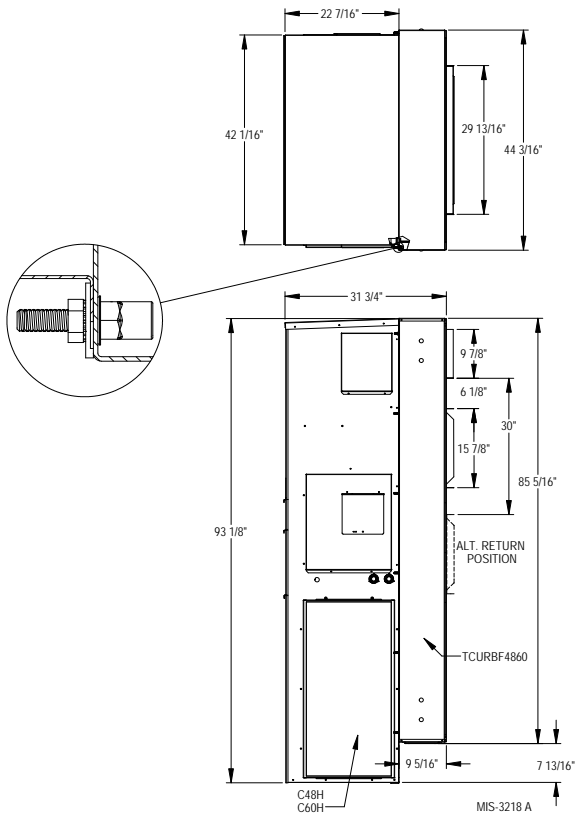

FIG. 4
TCURBT2430A

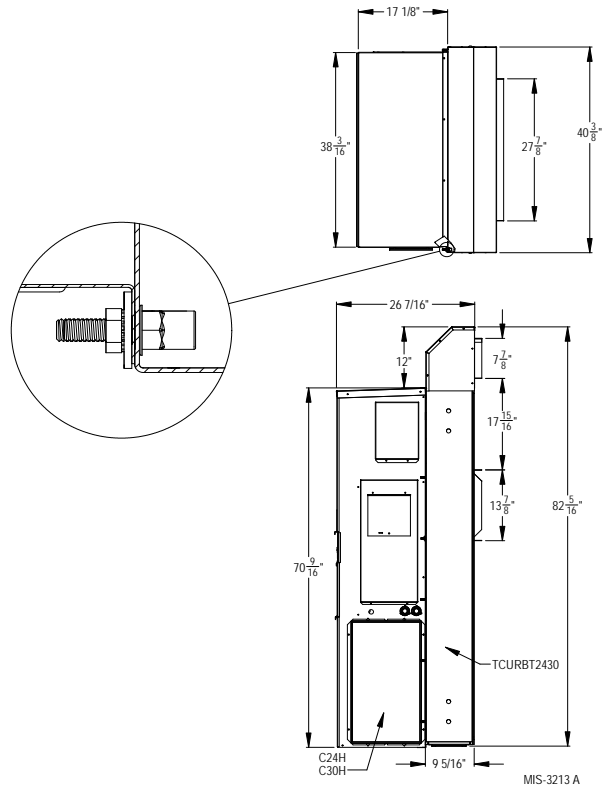

FIG. 5
TCURBT3642A

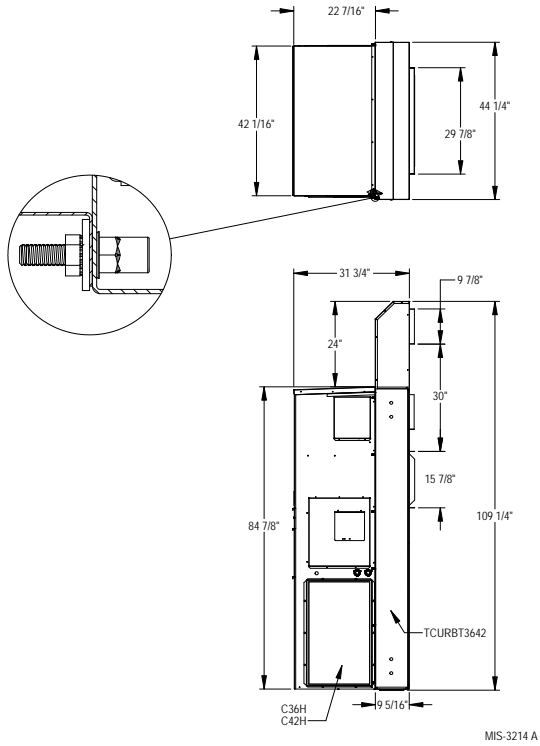

FIG. 6
TCURBT4860A

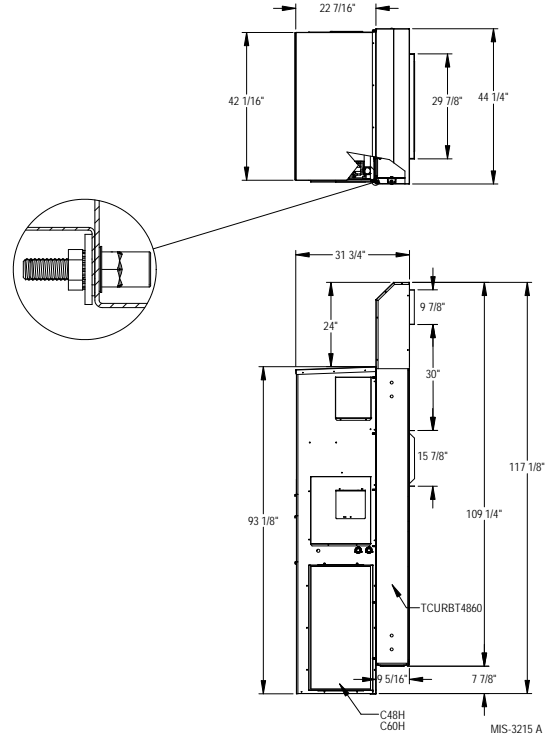

FIG. 7
WMICF3A

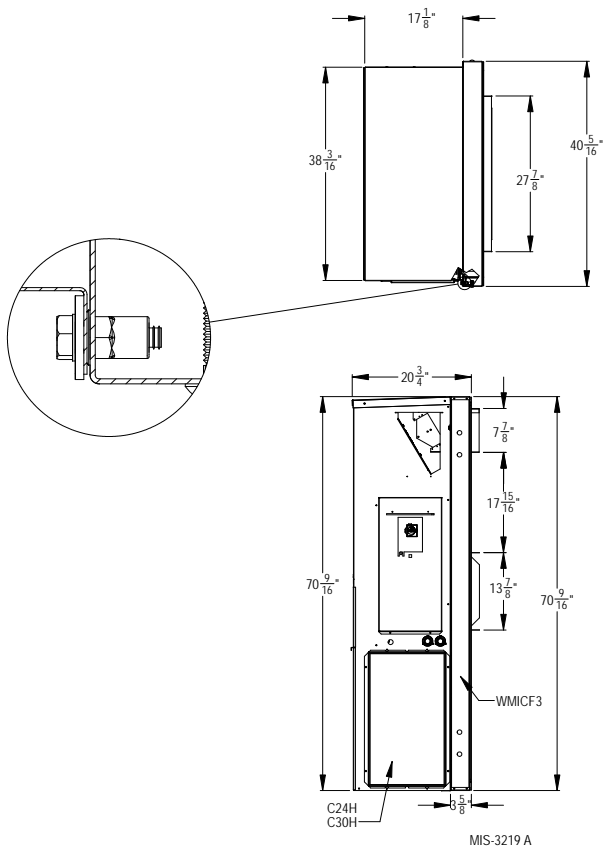

FIG. 8
WMICF5A

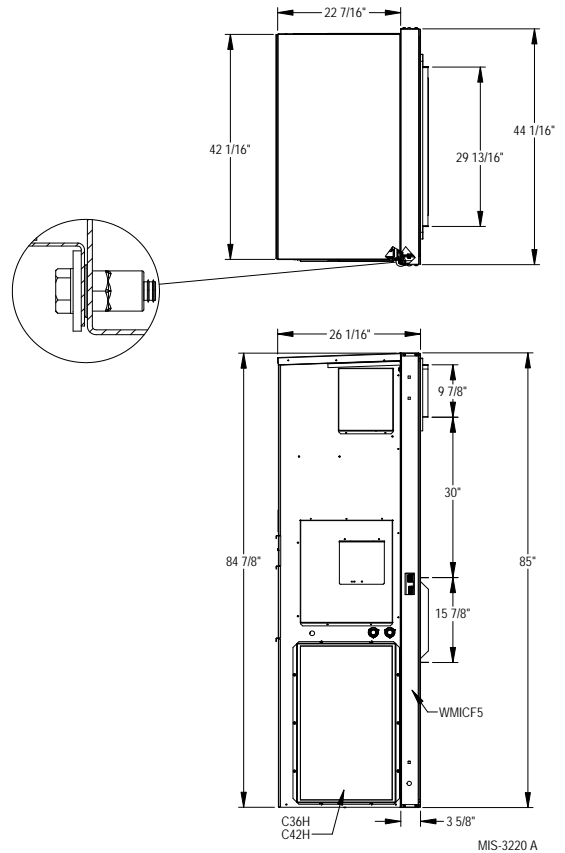

FIG. 9
WMICF5A

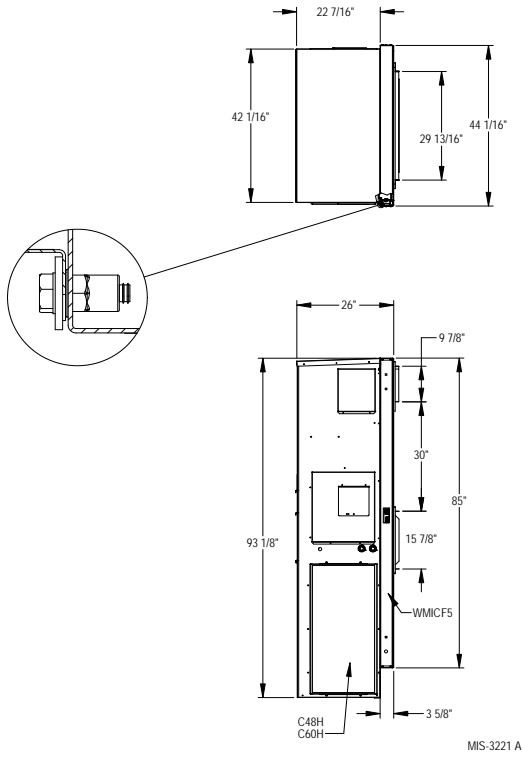
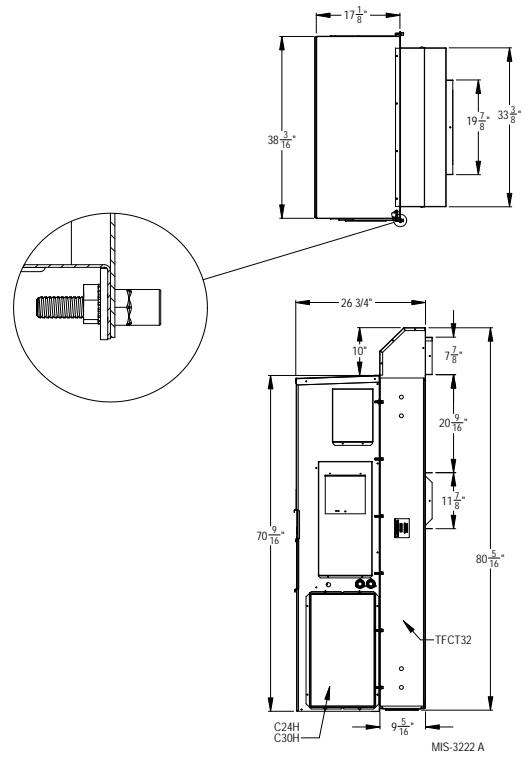

FIG. 10
TFCT-32A



* TFCT AND TFCF CURBS MAY REQUIRE WALL MODIFICATION FOR MOUNTING HOLE PATTERN.

FIG. 11
TFCT-53A

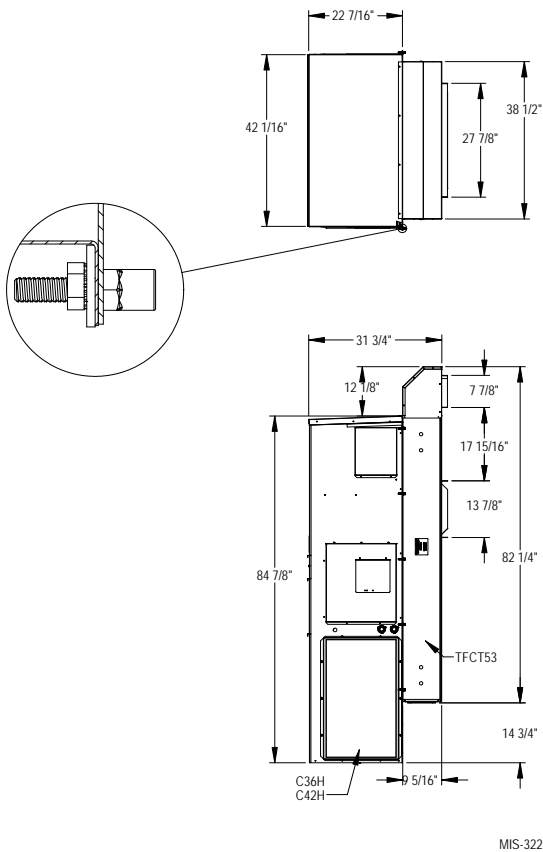
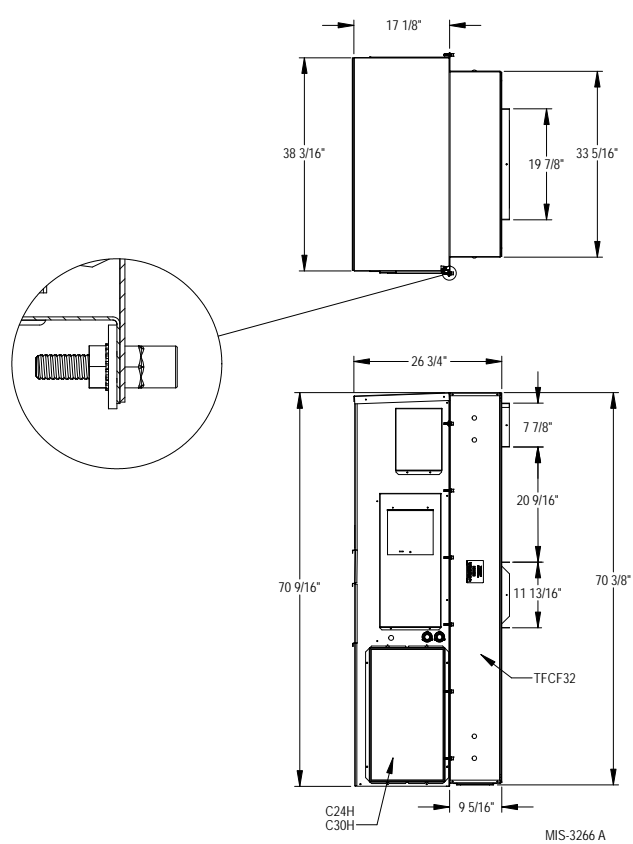
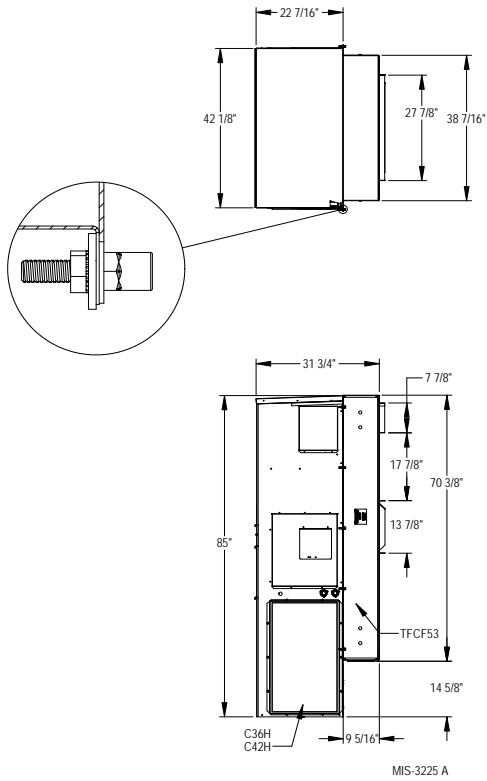

FIG. 12
TFCF-32A



PATENTED UNDER 9,004,995

**FIG. 13
TFCF-53A**



MIS-3225 A

**FIG. 14
WMRSC3SA**

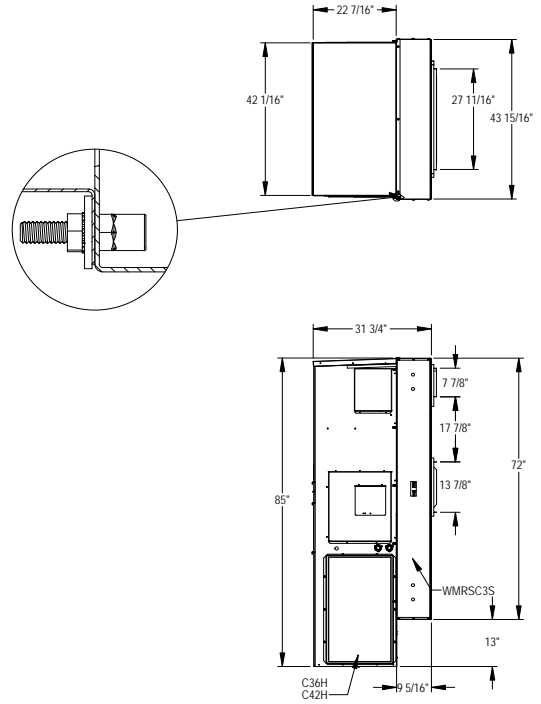

MIS-3226 A

*** TFCT AND TFCF CURBS MAY REQUIRE WALL MODIFICATION FOR MOUNTING HOLE PATTERN.**

PATENTED UNDER 9,004,995

CH Unit & T Curb Economizer Airflow Path

100% OUTSIDE AIRFLOW PATH

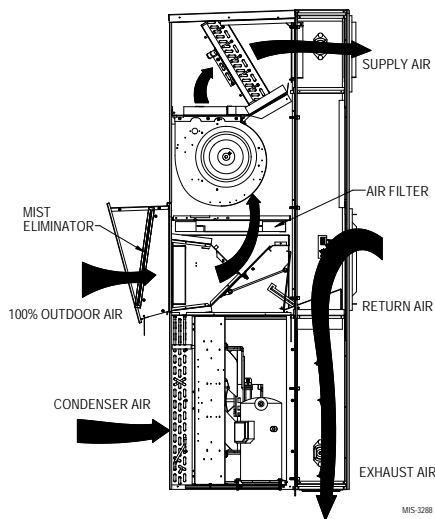

MIS-3288

MIXED AIRFLOW PATH

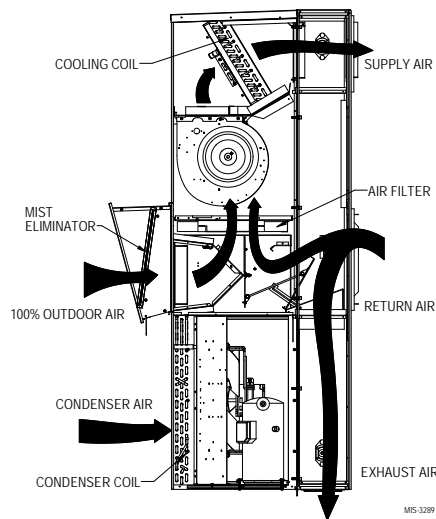

MIS-3289

100% CLOSED LOOP AIRFLOW PATH

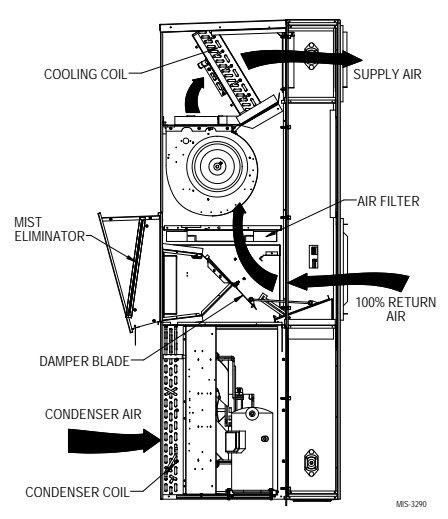

MIS-3290

**Return Air Acoustical Plenum
WAPR11**

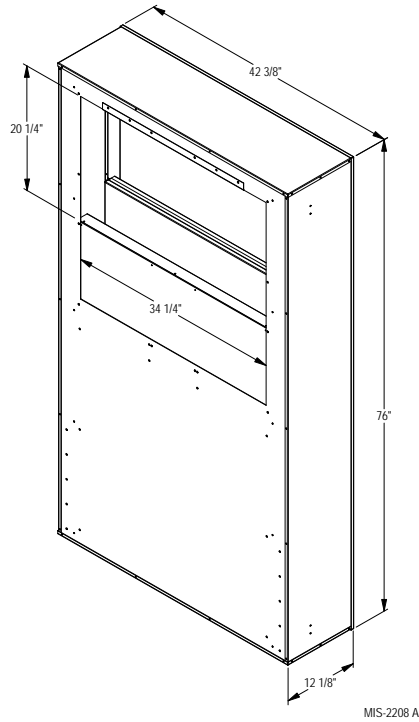

Duct Free Acoustical Plenum

	A	B
WAPFB31	7-7/8	27-7/8
WAPFB51	9-7/8	29-7/8
WAPFB51FF	9-7/8	29-7/8

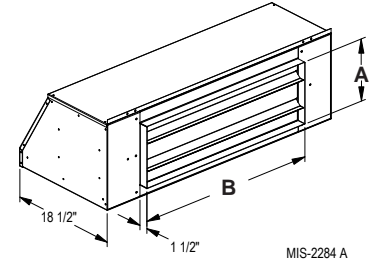
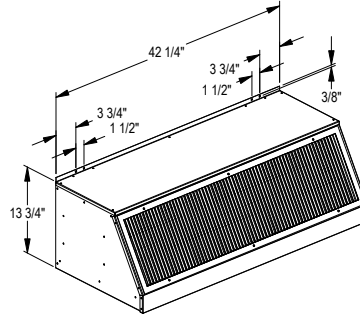

NOTE: WAPFB51FF same as shown, except has square front with grille straight up and down.

Optional Installation Accessories

Description	Model	Used With	Color	Shipping Weight (Lbs)
Return Air Acoustical Plenum	WAPR11-X WAPR11-4	C36H-C60H	Beige Buckeye Gray	205
Duct Free Supply Air Acoustical Plenum	WAPFB31-X WAPFB31-4	C24H-C30H	Beige Buckeye Gray	132
Ducted Supply Air Acoustical Plenum	WAPS51-G	C36H-C60H	Galvanized	140
Duct Free Supply Air Acoustical Plenum	WAPFB51-X WAPFB51-4	C36H-C60H	Beige Buckeye Gray	70
Duct Free Supply Air Acoustical Plenum	WAPFB51FF-X WAPFB51FF-4	C36H-C60H	Beige Buckeye Gray	70

**Supply Air Acoustical Plenum
WAPS51-G**

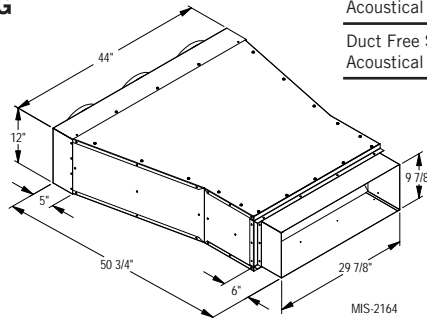
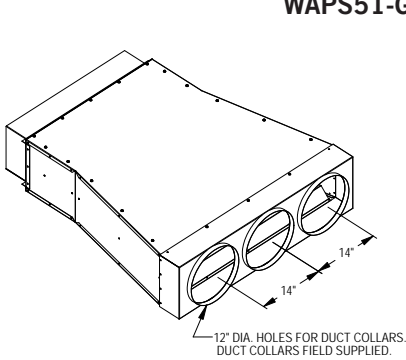

Typical installation with isolation curb, free blow, supply air acoustical plenum & return air acoustical plenum.

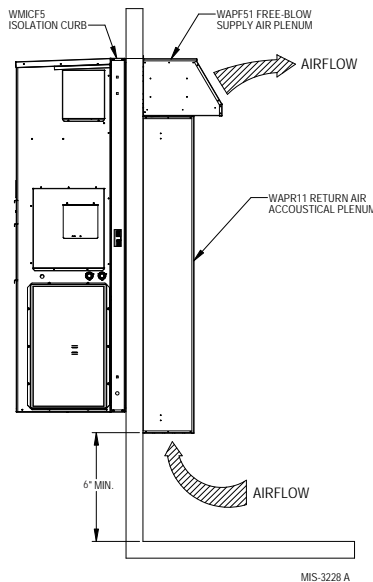

Patent 8,336,672

Typical Sound Performance with Installation/Isolation Curbs & Acoustical Plenums

C24H1 Sound Data Matrix (dBA @ 5 feet)

Unit Mounting	Free Blow Configuration				Front Outlet Ducted Configuration			
	Direct	TCURBF2430 Isolation Curb	TCURBF2430 Isolation Curb	TCURBF2430 Isolation Curb	Direct	Direct	TCURBF2430 Isolation Curb	TCURBF2430 Isolation Curb
Supply Air Treatment	Grille	Grille	Grille	WAPFB31 Free Blow Supply Air Plenum	Standard Supply Duct	Standard Supply Duct	Standard Supply Duct	WAPSS1-G Supply Air Silencer
Return Air Treatment	Grille	Grille	WAPR11-X Return Air Silencer	WAPR11-X Return Air Silencer	Grille	WAPR11-X Return Air Silencer	Grille	WAPR11-X Return Air Silencer
Blower Only Operation with CRV	NA	28.6	30.1	29.4	NA	NA	26.5	25.7
Compressor Stage 1 Operation with CRV	NA	43.2	40.2	40.4	NA	NA	43.7	39.4
Compressor Stage 2 Operation	NA	43.8	41.3	41.7	NA	NA	43.2	40.6
Compressor Stage 2 with ERV High Speed Operation								
Indoor Integrated dBA	NA	39.9	37.4	37.6	NA	NA	39.9	36.4
Compressor Stage 2 Outdoor Sound Level		65.4	65.4	65.4		65.4	65.4	65.4

Note 1: dBA is sound pressure measured 5 feet in front of unit and 5 feet above floor.

Note 2: Unit or isolation curb is mounted to frame construction.

Note 3: Results may vary depending upon other factors such as room size, type of construction and acoustical variances.

C30H1 Sound Data Matrix (dBA @ 5 feet)

Unit Mounting	Free Blow Configuration				Front Outlet Ducted Configuration			
	Direct	TCURBF2430 Isolation Curb	TCURBF2430 Isolation Curb	TCURBF2430 Isolation Curb	Direct	Direct	TCURBF2430 Isolation Curb	TCURBF2430 Isolation Curb
Supply Air Treatment	Grille	Grille	Grille	WAPFB31 Free Blow Supply Air Plenum	Standard Supply Duct	Standard Supply Duct	Standard Supply Duct	WAPSS1-G Supply Air Silencer
Return Air Treatment	Grille	Grille	WAPR11-X Return Air Silencer	WAPR11-X Return Air Silencer	Grille	WAPR11-X Return Air Silencer	Grille	WAPR11-X Return Air Silencer
Blower Only Operation	NA	35.5	33.8	32.5	NA	NA	31.2	32.5
Compressor Stage 1 Operation	NA	41.2	40.7	40.9	NA	NA	40.8	38.0
Compressor Stage 2 Operation	NA	44.3	43.1	43.2	NA	NA	42.3	40.9
Compressor Stage 2 with ERV High Speed Operation								
Indoor Integrated dBA	NA	40.0	38.9	38.8	NA	NA	38.2	36.7
Compressor Stage 2 Outdoor Sound Level		63.8	63.8	63.8			63.8	63.8

Note 1: dBA is sound pressure measured 5 feet in front of unit and 5 feet above floor.

Note 2: Unit or isolation curb is mounted to frame construction.

Note 3: Results may vary depending upon other factors such as room size, type of construction and acoustical variances.

C36H1 Sound Data Matrix (dBA @ 5 feet)

Unit Mounting	Free Blow Configuration				Front Outlet Ducted Configuration			
	Direct	TCURBF3642 Isolation Curb	TCURBF3642 Isolation Curb	TCURBF3642 Isolation Curb	Direct	Direct	TCURBF3642 Isolation Curb	TCURBF3642 Isolation Curb
Supply Air Treatment	Grille	Grille	Grille	WAPFB51 Free Blow Supply Air Plenum	Standard Supply Duct	Standard Supply Duct	Standard Supply Duct	WAPSS1-G Supply Air Silencer
Return Air Treatment	Grille	Grille	WAPR11-X Return Air Silencer	WAPR11-X Return Air Silencer	Grille	WAPR11-X Return Air Silencer	Grille	WAPR11-X Return Air Silencer
Blower Only Operation	37.1	32.7	32.6	30.2	36.1	32.3	28.7	29.3
Compressor Stage 1 Operation	53.6	45.7	40.9	40.0	51.1	42.8	39.7	38.0
Compressor Stage 2 Operation	53.3	46.1	42.4	41.8	51.8	43.5	40.0	39.8
Compressor Stage 2 with ERV High Speed Operation								
Indoor Integrated dBA	49.8	42.4	38.5	37.5	47.8	39.8	36.4	35.7
10' Compressor Stage 2 Outdoor Sound Level	62.6	62.6	62.6	62.6	62.6	62.6	62.6	62.6

Note 1: dBA is sound pressure measured 5 feet in front of unit and 5 feet above floor.

Note 2: Unit or isolation curb is mounted to frame construction.

Note 3: Results may vary depending upon other factors such as room size, type of construction and acoustical variances.

Typical Sound Performance with Installation/Isolation Curbs & Acoustical Plenums

C42H1 Sound Data Matrix (dBA @ 5 feet)

Unit Mounting	Free Blow Configuration				Front Outlet Ducted Configuration			
	Direct	TCURBF3642 Isolation Curb	TCURBF3642 Isolation Curb	TCURBF3642 Isolation Curb	Direct	Direct	TCURBF3642 Isolation Curb	TCURBF3642 Isolation Curb
Supply Air Treatment	Grille	Grille	Grille	WAPFB51 Free Blow Supply Air Plenum	Standard Supply Duct	Standard Supply Duct	Standard Supply Duct	WAPS51-G Supply Air Silencer
Return Air Treatment	Grille	Grille	WAPR11-X Return Air Silencer	WAPR11-X Return Air Silencer	Grille	WAPR11-X Return Air Silencer	Grille	WAPR11-X Return Air Silencer
Blower Only Operation with CRV	38.5	33.1	33.3	32.0	38.2	34.3	29.4	31.3
Compressor Stage 1 Operation with CRV	54.5	44.7	42.4	42.5	51.9	45.1	43.1	40.7
Compressor Stage 2 Operation	55.1	46.0	44.6	43.5	52.5	45.2	43.0	42.1
Compressor Stage 2 with ERV High Speed Operation								
Indoor Integrated dBA	51.1	41.9	40.2	39.6	48.6	41.8	39.5	38.1
Compressor Stage 2 Outdoor Sound Level	65.0	65.0	65.0	65.0	65.0	65.0	65.0	65.0

Note 1: dBA is sound pressure measured 5 feet in front of unit and 5 feet above floor.

Note 2: Unit or isolation curb is mounted to frame construction.

Note 3: Results may vary depending upon other factors such as room size, type of construction and acoustical variances.

C48H1 Sound Data Matrix (dBA @ 5 feet)

Unit Mounting	Free Blow Configuration				Front Outlet Ducted Configuration			
	Direct	TCURBF4860 Isolation Curb	TCURBF4860 Isolation Curb	TCURBF4860 Isolation Curb	Direct	Direct	TCURBF4860 Isolation Curb	TCURBF4860 Isolation Curb
Supply Air Treatment	Grille	Grille	Grille	WAPFB51 Free Blow Supply Air Plenum	Standard Supply Duct	Standard Supply Duct	Standard Supply Duct	WAPS51-G Supply Air Silencer
Return Air Treatment	Grille	Grille	WAPR11-X Return Air Silencer	WAPR11-X Return Air Silencer	Grille	WAPR11-X Return Air Silencer	Grille	WAPR11-X Return Air Silencer
Blower Only Operation	38.7	32.3	34.1	31.6	38.4	33.5	29.0	30.0
Compressor Stage 1 Operation	50.5	43.0	42.5	41.1	48.6	40.5	40.3	39.1
Compressor Stage 2 Operation	53.5	46.5	45.0	44.3	52.2	45.3	43.6	42.0
Compressor Stage 2 with ERV High Speed Operation								
Indoor Integrated dBA	48.5	41.3	40.5	39.4	47.0	39.9	38.5	37.2
Compressor Stage 2 Outdoor Sound Level	61.8	61.8	61.8	61.8	61.8	61.8	61.8	61.8

Note 1: dBA is sound pressure measured 5 feet in front of unit and 5 feet above floor.

Note 2: Unit or isolation curb is mounted to frame construction.

Note 3: Results may vary depending upon other factors such as room size, type of construction and acoustical variances.

C60H1 Sound Data Matrix (dBA @ 5 feet)

Unit Mounting	Free Blow Configuration				Front Outlet Ducted Configuration			
	Direct	TCURBF4860 Isolation Curb	TCURBF4860 Isolation Curb	TCURBF4860 Isolation Curb	Direct	Direct	TCURBF4860 Isolation Curb	TCURBF4860 Isolation Curb
Supply Air Treatment	Grille	Grille	Grille	WAPFB51 Free Blow Supply Air Plenum	Standard Supply Duct	Standard Supply Duct	Standard Supply Duct	WAPS51-G Supply Air Silencer
Return Air Treatment	Grille	Grille	WAPR11-X Return Air Silencer	WAPR11-X Return Air Silencer	Grille	WAPR11-X Return Air Silencer	Grille	WAPR11-X Return Air Silencer
Blower Only Operation	40.2	33.3	32.5	31.7	39.0	33.6	30.1	32.9
Compressor Stage 1 Operation	52.1	45.4	42.1	41.4	50.7	44.2	42.8	40.2
Compressor Stage 2 Operation	58.8	51.1	51.6	51.7	57.5	52.5	51.5	50.6
Compressor Stage 2 with ERV High Speed Operation								
Indoor Integrated dBA	52.4	45.0	44.7	44.7	51.1	45.8	44.7	43.7
Compressor Stage 2 Outdoor Sound Level	67.6	67.6	67.6	67.6	67.6	67.6	67.6	67.6

Note 1: dBA is sound pressure measured 5 feet in front of unit and 5 feet above floor.

Note 2: Unit or isolation curb is mounted to frame construction.

Note 3: Results may vary depending upon other factors such as room size, type of construction and acoustical variances.

Typical Sound Performance with Installation/Isolation Curbs & Acoustical Plenums

C24H1 Sound Data Matrix (dBA @ 10 feet)

Unit Mounting	Free Blow Configuration				Front Outlet Ducted Configuration			
	Direct	TCURBF2430 Isolation Curb	TCURBF2430 Isolation Curb	TCURBF2430 Isolation Curb	Direct	Direct	TCURBF2430 Isolation Curb	TCURBF2430 Isolation Curb
Supply Air Treatment	Grille	Grille	Grille	WAPFB51 Free Blow Supply Air Plenum	Standard Supply Duct	Standard Supply Duct	Standard Supply Duct	WAPS51-G Supply Air Silencer
Return Air Treatment	Grille	Grille	WAPR11-X Return Air Silencer	WAPR11-X Return Air Silencer	Grille	WAPR11-X Return Air Silencer	Grille	WAPR11-X Return Air Silencer
Blower Only Operation with CRV	NA	27.4	28.1	25.9	NA	NA	24.5	24.8
Compressor Stage 1 Operation with CRV	NA	40.4	37.2	37.8	NA	NA	39.7	37.7
Compressor Stage 2 Operation	NA	41.2	38.9	38.7	NA	NA	39.5	39.3
Compressor Stage 2 with ERV High Speed Operation								
Indoor Integrated dBA	NA	37.2	34.8	34.8	NA	NA	36.0	34.9
Compressor Stage 2 Outdoor Sound Level		65.4	65.4	65.4			65.4	65.4

Note 1: dBA is sound pressure measured 10 feet in front of unit and 5 feet above floor.

Note 2: Unit or isolation curb is mounted to frame construction.

Note 3: Results may vary depending upon other factors such as room size, type of construction and acoustical variances.

C30H1 Sound Data Matrix (dBA @ 10 feet)

Unit Mounting	Free Blow Configuration				Front Outlet Ducted Configuration			
	Direct	TCURBF2430 Isolation Curb	TCURBF2430 Isolation Curb	TCURBF2430 Isolation Curb	Direct	Direct	TCURBF2430 Isolation Curb	TCURBF2430 Isolation Curb
Supply Air Treatment	Grille	Grille	Grille	WAPFB51 Free Blow Supply Air Plenum	Standard Supply Duct	Standard Supply Duct	Standard Supply Duct	WAPS51-G Supply Air Silencer
Return Air Treatment	Grille	Grille	WAPR11-X Return Air Silencer	WAPR11-X Return Air Silencer	Grille	WAPR11-X Return Air Silencer	Grille	WAPR11-X Return Air Silencer
Blower Only Operation	NA	32.5	31.8	29.9	NA	NA	29.4	30.5
Compressor Stage 1 Operation	NA	38.6	36.7	36.3	NA	NA	38.7	37.5
Compressor Stage 2 Operation	NA	42.2	41.0	39.2	NA	NA	39.7	39.5
Compressor Stage 2 with ERV High Speed Operation								
Indoor Integrated dBA	NA	37.5	36.2	34.8	NA	NA	36.0	35.5
Compressor Stage 2 Outdoor Sound Level		63.8	63.8	63.8			63.8	63.8

Note 1: dBA is sound pressure measured 10 feet in front of unit and 5 feet above floor.

Note 2: Unit or isolation curb is mounted to frame construction.

Note 3: Results may vary depending upon other factors such as room size, type of construction and acoustical variances.

C36H1 Sound Data Matrix (dBA @ 10 feet)

Unit Mounting	Free Blow Configuration				Front Outlet Ducted Configuration			
	Direct	TCURBF3642 Isolation Curb	TCURBF3642 Isolation Curb	TCURBF3642 Isolation Curb	Direct	Direct	TCURBF3642 Isolation Curb	TCURBF3642 Isolation Curb
Supply Air Treatment	Grille	Grille	Grille	WAPFB51 Free Blow Supply Air Plenum	Standard Supply Duct	Standard Supply Duct	Standard Supply Duct	WAPS51-G Supply Air Silencer
Return Air Treatment	Grille	Grille	WAPR11-X Return Air Silencer	WAPR11-X Return Air Silencer	Grille	WAPR11-X Return Air Silencer	Grille	WAPR11-X Return Air Silencer
Blower Only Operation	35.1	31.7	30.4	27.6	33.0	29.9	27.2	27.1
Compressor Stage 1 Operation	48.7	43.5	40.9	37.1	47.0	40.2	39.7	38.3
Compressor Stage 2 Operation	48.8	43.8	42.4	38.8	48.1	40.8	40.0	38.4
Compressor Stage 2 with ERV High Speed Operation								
Indoor Integrated dBA	45.2	40.2	38.5	34.6	43.9	37.2	36.4	35.0
Compressor Stage 2 Outdoor Sound Level	62.6	62.6	62.6	62.6	62.6	62.6	62.6	62.6

Note 1: dBA is sound pressure measured 10 feet in front of unit and 5 feet above floor.

Note 2: Unit or isolation curb is mounted to frame construction.

Note 3: Results may vary depending upon other factors such as room size, type of construction and acoustical variances.

Typical Sound Performance with Installation/Isolation Curbs & Acoustical Plenums

C42H1 Sound Data Matrix (dBA @ 10 feet)

Unit Mounting	Free Blow Configuration				Front Outlet Ducted Configuration			
	Direct	TCURBF3642 Isolation Curb	TCURBF3642 Isolation Curb	TCURBF3642 Isolation Curb	Direct	Direct	TCURBF3642 Isolation Curb	TCURBF3642 Isolation Curb
Supply Air Treatment	Grille	Grille	Grille	WAPFB51 Free Blow Supply Air Plenum	Standard Supply Duct	Standard Supply Duct	Standard Supply Duct	WAPS51-G Supply Air Silencer
Return Air Treatment	Grille	Grille	WAPR11-X Return Air Silencer	WAPR11-X Return Air Silencer	Grille	WAPR11-X Return Air Silencer	Grille	WAPR11-X Return Air Silencer
Blower Only Operation with CRV	35.7	31.5	30.3	28.6	35.0	31.6	27.6	29.3
Compressor Stage 1 Operation with CRV	48.7	43.0	41.3	40.0	49.2	40.4	42.1	39.0
Compressor Stage 2 Operation	49.0	44.5	42.2	40.6	50.3	42.5	41.7	40.5
Compressor Stage 2 with ERV High Speed Operation								
Indoor Integrated dBA	45.3	40.3	38.3	36.9	46.1	38.2	38.4	36.4
Compressor Stage 2 Outdoor Sound Level	65.0	65.0	65.0	65.0	65.0	65.0	65.0	65.0

Note 1: dBA is sound pressure measured 10 feet in front of unit and 5 feet above floor.

Note 2: Unit or isolation curb is mounted to frame construction.

Note 3: Results may vary depending upon other factors such as room size, type of construction and acoustical variances.

C48H1 Sound Data Matrix (dBA @ 10 feet)

Unit Mounting	Free Blow Configuration				Front Outlet Ducted Configuration			
	Direct	TCURBF4860 Isolation Curb	TCURBF4860 Isolation Curb	TCURBF4860 Isolation Curb	Direct	Direct	TCURBF4860 Isolation Curb	TCURBF4860 Isolation Curb
Supply Air Treatment	Grille	Grille	Grille	WAPFB51 Free Blow Supply Air Plenum	Standard Supply Duct	Standard Supply Duct	Standard Supply Duct	WAPS51-G Supply Air Silencer
Return Air Treatment	Grille	Grille	WAPR11-X Return Air Silencer	WAPR11-X Return Air Silencer	Grille	WAPR11-X Return Air Silencer	Grille	WAPR11-X Return Air Silencer
Blower Only Operation	36.1	32.2	31.7	28.4	35.3	30.8	27.6	27.4
Compressor Stage 1 Operation	45.8	41.3	40.2	38.4	45.9	38.2	39.0	38.8
Compressor Stage 2 Operation	49.6	45.0	42.1	41.3	49.0	42.7	42.1	40.8
Compressor Stage 2 with ERV High Speed Operation								
Indoor Integrated dBA	44.4	39.9	37.9	36.5	44.0	37.4	37.1	36.3
Compressor Stage 2 Outdoor Sound Level	61.8	61.8	61.8	61.8	61.8	61.8	61.8	61.8

Note 1: dBA is sound pressure measured 10 feet in front of unit and 5 feet above floor.

Note 2: Unit or isolation curb is mounted to frame construction.

Note 3: Results may vary depending upon other factors such as room size, type of construction and acoustical variances.

C60H1 Sound Data Matrix (dBA @ 10 feet)

Unit Mounting	Free Blow Configuration				Front Outlet Ducted Configuration			
	Direct	TCURBF4860 Isolation Curb	TCURBF4860 Isolation Curb	TCURBF4860 Isolation Curb	Direct	Direct	TCURBF4860 Isolation Curb	TCURBF4860 Isolation Curb
Supply Air Treatment	Grille	Grille	Grille	WAPFB51 Free Blow Supply Air Plenum	Standard Supply Duct	Standard Supply Duct	Standard Supply Duct	WAPS51-G Supply Air Silencer
Return Air Treatment	Grille	Grille	WAPR11-X Return Air Silencer	WAPR11-X Return Air Silencer	Grille	WAPR11-X Return Air Silencer	Grille	WAPR11-X Return Air Silencer
Blower Only Operation	37.1	31.7	29.9	29.0	35.7	29.6	27.9	27.5
Compressor Stage 1 Operation	48.2	42.8	41.0	39.4	48.1	40.9	42.4	39.1
Compressor Stage 2 Operation	54.8	47.7	45.3	45.0	54.5	47.3	48.2	44.1
Compressor Stage 2 with ERV High Speed Operation								
Indoor Integrated dBA	48.5	42.3	39.8	39.0	48.2	41.0	42.0	38.3
Compressor Stage 2 Outdoor Sound Level	67.6	67.6	67.6	67.6	67.6	67.6	67.6	67.6

Note 1: dBA is sound pressure measured 10 feet in front of unit and 5 feet above floor.

Note 2: Unit or isolation curb is mounted to frame construction.

Note 3: Results may vary depending upon other factors such as room size, type of construction and acoustical variances.

Part Load Cooling Application Data - Outdoor Temperature °F ① ②

Model	D.B. / W.B. ③	COOLING CAPACITY	75°F	80°F	85°F	90°F	95°F	100°F	105°F	110°F	115°F	120°F
C24H1	75/62	Total Cooling Sensible Cooling	17,500 13,900	16,300 13,200	15,300 12,700	14,200 12,100	13,100 11,600	12,100 11,200	11,200 10,900	10,400 10,600	9,500 10,300	8,600 10,100
	80/67	Total Cooling Sensible Cooling	18,600 13,400	17,700 12,900	16,900 12,500	16,000 12,100	15,000 11,700	14,100 11,400	13,200 11,100	12,300 10,900	11,400 10,700	10,400 10,500
	85/72	Total Cooling Sensible Cooling	22,200 13,800	20,700 13,100	19,400 12,600	18,100 12,100	16,700 11,500	15,500 11,100	14,300 10,600	13,100 10,300	12,000 9,900	10,800 9,500
C30H1	75/62	Total Cooling Sensible Cooling	23,500 18,000	22,100 17,500	20,800 17,000	19,600 16,400	18,500 16,000	17,500 15,500	16,600 14,900	15,800 14,500	15,000 14,000	14,300 13,500
	80/67	Total Cooling Sensible Cooling	25,100 17,400	24,000 17,100	23,100 16,800	22,100 16,400	21,200 16,100	20,400 15,700	19,600 15,300	18,800 15,000	18,000 14,500	17,300 14,100
	85/72	Total Cooling Sensible Cooling	29,900 17,900	28,100 17,400	26,600 16,900	25,000 16,300	23,600 15,800	22,300 15,200	21,200 14,600	20,000 14,100	18,900 13,400	18,000 12,800
C36H1	75/62	Total Cooling Sensible Cooling	26,600 20,700	24,800 20,100	23,300 19,500	21,800 19,000	20,400 18,400	19,300 17,800	18,200 17,200	17,200 16,600	16,300 15,900	15,500 15,200
	80/67	Total Cooling Sensible Cooling	28,400 20,000	27,000 19,700	25,800 19,300	24,600 19,000	23,400 18,500	22,400 18,100	21,400 17,600	20,500 17,100	19,600 16,500	18,800 15,900
	85/72	Total Cooling Sensible Cooling	33,900 20,500	31,600 20,000	29,700 19,400	27,800 18,900	26,000 18,200	24,500 17,500	23,100 16,800	21,800 16,100	20,600 15,200	19,600 14,400
C42H1	75/62	Total Cooling Sensible Cooling	30,700 23,200	28,500 23,000	26,600 22,600	24,900 22,100	23,400 21,500	22,100 20,900	21,000 20,100	20,200 19,200	19,400 18,100	18,800 17,000
	80/67	Total Cooling Sensible Cooling	32,700 22,500	31,400 22,500	29,500 22,400	28,100 22,100	26,800 21,700	25,700 21,200	24,800 20,600	24,000 19,800	23,300 18,800	22,800 17,800
	85/72	Total Cooling Sensible Cooling	39,000 23,100	36,300 22,900	33,900 22,500	31,800 22,000	29,800 21,300	28,100 20,500	26,800 19,700	25,600 18,600	24,500 17,300	23,700 16,100
C48H1	75/62	Total Cooling Sensible Cooling	35,300 27,500	34,000 27,200	32,600 26,800	31,200 26,300	29,600 25,700	28,100 25,100	26,500 24,300	24,800 23,300	23,000 22,400	21,200 21,300
	80/67	Total Cooling Sensible Cooling	37,700 26,600	35,800 26,600	36,200 26,500	35,200 26,300	34,000 25,900	32,700 25,500	31,200 24,900	29,500 24,100	27,700 23,300	25,700 22,300
	85/72	Total Cooling Sensible Cooling	44,900 27,300	43,300 27,000	41,600 26,600	39,800 26,100	37,800 25,400	35,800 24,700	33,700 23,800	31,400 22,600	29,100 21,500	26,700 20,200
C60H1	75/62	Total Cooling Sensible Cooling	43,300 33,900	41,300 33,100	39,500 32,300	37,500 31,400	35,500 30,500	33,700 29,600	31,800 28,700	30,000 27,700	28,100 26,700	26,300 25,700
	80/67	Total Cooling Sensible Cooling	46,200 32,900	43,000 32,400	43,800 32,000	42,400 31,400	40,800 30,800	39,200 30,100	37,500 29,400	35,700 28,600	33,800 27,800	31,800 26,900
	85/72	Total Cooling Sensible Cooling	55,100 33,700	52,600 32,900	50,300 32,200	47,900 31,200	45,300 30,200	42,900 29,100	40,500 28,000	38,000 26,800	35,500 25,600	33,100 24,300

- ① Below 65°F, unit requires a factory or field installed low ambient control.
 ② Outdoor temperatures shown are measured at the condenser section air inlet.
 ③ Return air temperature °F.

Capacity Multiplier Factors			
% of Rated Airflow	-10	Rated	+10
Total BTUH	0.975	1.0	1.02
Sensible BTUH	0.950	1.0	1.05

Part Load Heating Application Rating & Outdoor Temperature °F* ②

MODEL		0°	5°	10°	15°	20°	25°	30°	35°	40°	45°	50°	55°	60°F
C24H1	BTUH	3,600	4,700	5,900	7,000	8,100	9,300	10,400	11,600	12,700	13,800	14,900	16,100	17,200
	WATTS	1390	1400	1410	1410	1420	1420	1420	1410	1440	1460	1470	1480	1490
	COP	0.76	0.99	1.23	1.46	1.68	1.92	2.15	2.42	2.59	2.77	2.97	3.19	3.39
C30H1	BTUH	6,200	7,600	8,900	10,300	11,500	12,500	13,500	14,600	16,400	18,300	19,900	21,200	22,600
	WATTS	1680	1700	1720	1740	1760	1700	1770	1780	1820	1860	1890	1910	1930
	COP	1.09	1.31	1.52	1.74	1.92	2.07	2.24	2.41	2.65	2.89	3.09	3.26	3.44
C36H1	BTUH	7,000	8,600	10,100	11,600	13,100	14,400	15,700	17,100	18,900	20,700	22,400	23,900	25,400
	WATTS	1930	1940	1960	1970	1980	1980	1990	1990	2020	2060	2080	2090	2110
	COP	1.07	1.30	1.51	1.73	1.94	2.14	2.32	2.52	2.75	2.95	3.16	3.36	3.53
C42H1	BTUH	8,800	10,600	12,500	14,300	16,200	18,100	20,000	21,900	23,600	25,400	27,100	29,000	30,800
	WATTS	2340	2360	2390	2410	2410	2400	2380	2370	2450	2540	2590	2610	2640
	COP	1.11	1.32	1.54	1.74	1.97	2.21	2.47	2.71	2.83	2.93	3.07	3.26	3.42
C48H1	BTUH	10,800	12,900	15,100	17,200	18,900	20,300	21,600	23,000	26,300	29,500	32,100	34,300	36,400
	WATTS	2490	2520	2550	2580	2590	2600	2600	2600	2670	2740	2790	2820	2850
	COP	1.28	1.50	1.74	1.96	2.14	2.29	2.44	2.60	2.89	3.16	3.38	3.57	3.75
C60H1	BTUH	11,400	14,200	17,100	19,900	22,700	25,500	28,300	31,000	33,900	36,900	39,700	42,600	45,400
	WATTS	2860	2900	2950	2990	3040	3110	3170	3230	3250	3260	3290	3340	3380
	COP	1.17	1.44	1.70	1.96	2.19	2.41	2.62	2.82	3.06	3.32	3.54	3.74	3.94

* 70°F DB indoor return air at rated CFM includes defrost operation below 45°.

② Outdoor temperatures shown are measured at the condenser section air inlet.

Full Load Cooling Application Data - Outdoor Temperature °F ①②

Model	D.B. / W.B. ③	COOLING CAPACITY	75°F	80°F	85°F	90°F	95°F	100°F	105°F	110°F	115°F	120°F
C24H1	75/62	Total Cooling Sensible Cooling	24,400 19,200	23,200 18,800	22,000 18,300	20,700 17,700	19,400 17,200	18,100 16,500	16,700 15,800	15,400 15,100	13,900 14,400	12,400 13,600
	80/67	Total Cooling Sensible Cooling	26,000 18,600	26,000 18,600	24,400 18,100	23,400 17,700	22,200 17,300	21,000 16,800	19,700 16,200	18,300 15,600	16,700 14,900	15,000 14,200
	85/72	Total Cooling Sensible Cooling	31,000 19,100	29,500 18,700	28,100 18,200	26,500 17,600	24,700 17,000	23,000 16,300	21,300 15,500	19,500 14,700	17,600 13,800	15,600 12,900
C30H1	75/62	Total Cooling Sensible Cooling	31,200 24,300	29,600 23,400	28,100 22,600	26,700 22,000	25,500 21,300	24,300 20,800	23,200 20,200	22,100 19,700	21,000 19,200	20,100 18,800
	80/67	Total Cooling Sensible Cooling	33,300 23,500	32,200 22,900	31,200 22,400	30,200 22,000	29,200 21,500	28,300 21,100	27,300 20,700	26,300 20,300	25,300 19,900	24,300 19,600
	85/72	Total Cooling Sensible Cooling	39,700 24,100	37,700 23,300	35,900 22,500	34,100 21,900	32,500 21,100	31,000 20,400	29,500 19,800	28,000 19,100	26,600 18,400	25,300 17,700
C36H1	75/62	Total Cooling Sensible Cooling	37,200 29,500	35,500 28,700	33,800 27,800	32,100 26,900	30,500 26,100	28,900 25,300	27,400 24,500	25,800 23,600	24,400 22,900	22,900 22,100
	80/67	Total Cooling Sensible Cooling	39,700 28,600	38,600 28,100	37,500 27,500	36,300 26,900	35,000 26,300	33,700 25,700	32,300 25,100	30,800 24,400	29,300 23,800	27,700 23,100
	85/72	Total Cooling Sensible Cooling	47,300 29,300	45,200 28,500	43,100 27,700	41,000 26,700	38,900 25,800	36,900 24,900	34,900 23,900	32,800 22,900	30,800 21,900	28,800 20,900
C42H1	75/62	Total Cooling Sensible Cooling	42,100 33,400	40,100 32,400	38,300 31,300	36,500 30,400	34,700 29,500	33,000 28,600	31,300 27,800	29,700 27,100	28,100 26,400	26,500 25,700
	80/67	Total Cooling Sensible Cooling	44,900 32,400	43,700 31,700	42,500 31,000	41,200 30,400	40,000 29,700	38,400 29,100	36,900 28,500	35,400 28,000	33,800 27,400	32,100 26,900
	85/72	Total Cooling Sensible Cooling	53,500 33,200	51,100 32,200	48,800 31,200	46,500 30,200	44,200 29,200	42,000 28,200	39,800 27,200	37,700 26,300	35,500 25,300	33,400 24,300
C48H1	75/62	Total Cooling Sensible Cooling	48,800 39,400	46,600 38,500	44,600 37,600	42,500 36,700	40,500 35,700	38,600 34,800	36,800 33,800	35,000 32,800	33,200 31,800	31,400 30,800
	80/67	Total Cooling Sensible Cooling	52,100 38,200	50,800 37,700	49,500 37,200	48,000 36,700	45,500 36,000	45,000 35,400	43,400 34,700	41,700 33,900	39,900 33,100	38,000 32,200
	85/72	Total Cooling Sensible Cooling	62,100 39,100	59,400 38,300	56,900 37,400	54,200 36,500	51,700 35,300	49,200 34,300	46,800 33,100	44,400 31,800	41,900 30,500	39,500 29,100
C60H1	75/62	Total Cooling Sensible Cooling	58,100 45,200	55,600 43,700	53,200 42,400	51,000 41,100	48,800 39,900	46,700 38,800	44,700 37,800	42,700 36,900	40,800 36,000	38,900 35,200
	80/67	Total Cooling Sensible Cooling	62,000 43,800	60,600 42,800	59,100 42,000	57,600 41,100	55,500 40,300	54,400 39,500	52,700 38,800	50,900 38,100	49,100 37,400	47,200 36,800
	85/72	Total Cooling Sensible Cooling	73,900 44,900	70,900 43,400	67,900 42,200	65,000 40,800	62,200 39,500	59,500 38,200	56,800 37,000	54,200 35,700	51,600 34,500	49,100 33,300

- ① Below 65°F, unit requires a factory or field installed low ambient control.
 ② Outdoor temperatures shown are measured at the condenser section air inlet.
 ③ Return air temperature °F.

Capacity Multiplier Factors			
% of Rated Airflow	-10	Rated	+10
Total BTUH	0.975	1.0	1.02
Sensible BTUH	0.950	1.0	1.05

Full Load Heating Application Rating & Outdoor Temperature °F* ②

MODEL		0°	5°	10°	15°	20°	25°	30°	35°	40°	45°	50°	55°	60°F
C24H1	BTUH	5,100	6,600	8,100	9,600	11,100	12,400	13,800	15,200	16,900	18,600	20,100	21,600	23,100
	WATTS	1570	1600	1620	1640	1660	1680	1690	1710	1750	1790	1820	1840	1860
	COP	0.96	1.21	1.47	1.72	1.96	2.17	2.40	2.61	2.83	3.05	3.24	3.44	3.64
C30H1	BTUH	10,600	12,200	13,800	15,400	16,400	16,900	17,400	17,900	21,200	24,400	26,600	28,200	29,800
	WATTS	2000	2030	2060	2100	2120	2120	2130	2130	2210	2290	2340	2380	2410
	COP	1.56	1.77	1.97	2.15	2.27	2.34	2.40	2.47	2.82	3.13	3.34	3.48	3.63
C36H1	BTUH	12,200	14,200	16,200	18,200	19,900	21,200	22,600	24,000	26,900	29,900	32,200	34,200	36,200
	WATTS	2270	2300	2340	2380	2410	2430	2450	2470	2530	2600	2640	2680	2720
	COP	1.58	1.81	2.03	2.25	2.42	2.56	2.71	2.85	3.12	3.37	3.58	3.74	3.90
C42H1	BTUH	14,000	16,600	19,300	22,000	23,900	25,400	26,900	28,400	32,800	37,300	40,600	43,300	46,000
	WATTS	2750	2810	2870	2930	2960	2970	2980	2990	3130	3270	3370	3430	3490
	COP	1.50	1.74	1.98	2.20	2.37	2.51	2.65	2.79	3.08	3.35	3.53	3.70	3.87
C48H1	BTUH	18,000	20,600	23,300	26,000	28,000	29,500	31,100	32,700	37,000	41,300	44,600	47,300	50,000
	WATTS	3010	3070	3130	3190	3240	3280	3320	3360	3450	3540	3610	3670	3730
	COP	1.76	1.97	2.19	2.39	2.54	2.64	2.75	2.86	3.15	3.42	3.62	3.78	3.93
C60H1	BTUH	24,800	27,700	30,600	33,500	35,800	37,600	39,400	41,300	45,800	50,300	53,800	56,700	59,600
	WATTS	3770	3850	3930	4010	4080	4140	4200	4260	4370	4470	4560	4640	4720
	COP	1.93	2.11	2.29	2.45	2.58	2.67	2.75	2.85	3.08	3.30	3.46	3.59	3.70

- * 70°F DB indoor return air at rated CFM includes defrost operation below 45°.
 ② Outdoor temperatures shown are measured at the condenser section air inlet.

Indoor Blower Performance - CFM (0.00" — 0.50" H₂O) ①

Model	Rated ESP	① Max ESP	② Blower Only	Cooling & Heat Pump Stage 1	④ Cooling & Heat Pump Stage 2	④ Electric Heat
C24H	.10	.50	550	550	740	900
C30H	.10	.50	650	650	900	900
C36H	.15	.50	800	800	1100	1100
C42H	.15	.50	800	900 ③	1250	1250
C48H	.20	.50	825	1000 ③	1550	1550
C60H	.20	.50	850	1300 ③	1650	1650

NOTE: These units are equipped with a variable speed (ECM) indoor motor that automatically adjusts itself to maintain approximately the same rate of indoor airflow in both heating & cooling, dry & wet coil conditions and at both 230/208 or 460 volts.

- ① Maximum ESP (inches WC) shown is with 2" thick disposable filter.
- ② Blower only CFM is the total air being circulated during continuous fan only mode.
- ③ Blower only CFM reduces during continuous fan only mode.
- ④ CFM output on Stage 2 Cooling and Heat Pump or Electric Heat.

Electric Heat Table - Refer to Electrical Specifications for Availability by Unit Model

Nominal KW	At 240V (1)				At 208V (1)				At 480V (2)			At 460V (2)		
	KW	1-Ph Amps	3-Ph Amps	Btuh	KW	1-Ph Amps	3-Ph Amps	Btuh	KW	3-Ph Amps	Btuh	KW	3-Ph Amps	Btuh
4.0	4.0	16.7		13,652	3.00	14.4		10,239						
5.0	5.0	20.8		17,065	3.75	18.0		12,799						
6.0	6.0		14.4	20,478	4.50		12.5	15,359	6.0	7.2	20,478	5.52	6.9	18,840
8.0	8.0	33.3		27,304	6.00	28.8		20,478						
9.0	9.0		21.7	30,717	6.75		18.7	23,038	9.0	10.8	30,717	8.28	10.4	28,260
10.0	10.0	41.7		34,130	7.50	36.1		25,598						
15.0	15.0	62.5	36.1	51,195	11.25	54.1	31.2	38,396	15.0	18.0	51,195	13.80	17.3	47,099
18.0			43.4	61,434	13.5		37.4	46,076	18.0	21.6	61,434	16.56	20.8	56,520
20.0	20.0	83.3		68,260	15.00	72.1		51,195						

- (1) These electric heaters are available in 230/208V units only.
- (2) These electric heaters are available in 480V units only.

Heater Packages - Field Installed

- Designed for adding Electric Heat to 0 KW Units
- ETL – US & Canada Listed
- Circuit Breaker standard on 230/208V Models
- Rotary Disconnect standard on 460V Models

Heat Pump Models	-A00 Models 230/208-1		-B00 Models 230/208-3		-C00 Models 460-3	
	Heater Model #	KW	Heater Model #	KW	Heater Model #	KW
C24H1	EHT03H-A04B	4	EHT02H-B06B	6		
	EHT03H-AF8B	F8	EHT03H-B09B	9		
	EHT03H-AS8B	S8				
C30H1	EHT03H-A04B	4	EHT03H-B06B	6	EHT03H-C06	6
	EHT03H-AF8B	F8	EHT03H-B09B	9	EHT03H-C09	9
	EHT03H-AS8B	S8				
C36H1	EHS03H-A05B	5	EHT05H-B06B	6	EHS05H-C06	6
	EHT05H-A10B	10	EHT05H-B09B	9	EHS03H-C09	9
	EHT05H-A15B	15	EHS05H-B15B	15	EHS03H-C15	15
C42H1	EHS03H-A05B	5	EHS05H-B06B	6	EHS05H-C06	6
	EHT05H-A10B	10	EHS05H-B09B	9	EHS05H-C09	9
	EHT05H-A15B	15	EHS05H-B15B	15	EHS05H-C15	15
C48H1	EHT06H-A04B	4	EHT06H-B06B	6	EHT06H-C06	6
	EHT06H-A05B	5	EHT06H-B09B	9	EHT06H-C09	9
	EHT06H-A10B	10	EHT06H-B15B	15	EHT06H-C15	15
	EHT06H-A15B	15	EHT06H-B18B	18		
	EHT06H-A20B	20				
C60H1	EHT06H-A05B	5	EHT06H-B06B	6	EHT06H-C06	6
	EHT06H-A10B	10	EHT06H-B09B	9	EHT06H-C09	9
	EHT06H-A15B	15	EHT06H-B15B	15	EHT06H-C15	15
	EHT06H-A20B	20	EHT06H-B18B	18	EHT06H-C18	18

Heat Pump Wall-Mount Model Nomenclature

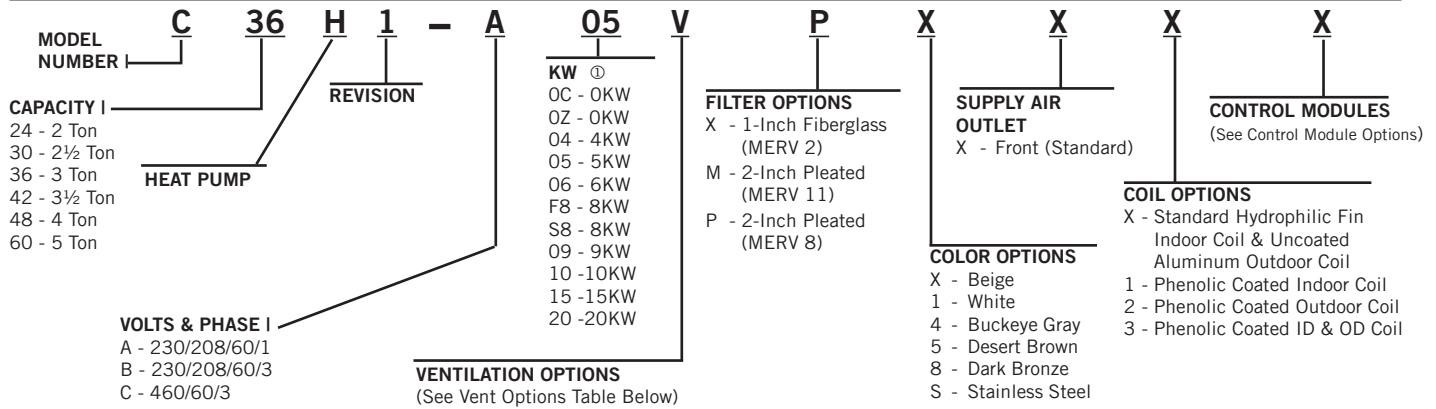

Note ① All 230/208V units with or without electric heat have circuit breaker. 0C is for 460V circuit breaker & 0KW. No 460V electric heat options w/circuit breaker available. 460V -0Z and all 460V KW options are with Rotary Disconnect. See Page 9 for available heater options by unit model number.

Ventilation Options

MODELS	C24H1, C30H1		C36H1, C42H1, C48H1, C60H1	
	Factory Installed Code No.	Field Installed Part No.	Factory Installed Code No.	Field Installed Part No.
Blank-Off Plate	B	BOP-3	B	BOP-5
Commercial Ventilator - Modulating Spring Return w/Exhaust	V	CHCRV-3 ③	V	CHCRV-5
Economizer (Internal) - Fully Modulating w/Exhaust mn	S	ECONCHS-E3 ②③	S	ECONCHS-E5 ②③
Energy Recovery Ventilator - 230V ①	R	CHERV-A3 ②③	R	CHERV-A5 ②③
Energy Recovery Ventilator - 460V ①	R	CHERV-C3 ②③	R	CHERV-C5 ②③

- ① Intake and exhaust can be independently adjusted.
- ② Insert color to match unit ("X" = Beige; "4" = Buckeye Gray; etc.)
- ③ Requires use of TCURB, depending on unit model, when installing ECONCHS-E3, -E5 or CHCRV-3. See Page 10 for additional information.

NOTE: The WMDK Door Kit cannot be used with the CH Product-Line, due to door sizes.

All parts are included in the field installed vent kits, including door panels.

Heat Pump Control Modules

DESCRIPTION									
Low Pressure Control ①	High Pressure Control ①	Low Ambient Control & Relay ②	Start Kit ③	Start Kit ④	Outdoor Sensor	Freezestat ⑥	Dirty Filter Switch ⑦	Factory Installed Code Number	Field Installed Part Number
STD	STD							X	N/A
STD	STD	C24-48 ● 230V						E	CMH-20
STD	STD	C24-48 ● 460V						E	CMH-21
STD	STD	C60 ● All						E	CMH-19
STD	STD		●					Field Installed Only	CMC-15 ③
STD	STD			●				Field Installed Only	SK111 ④
STD	STD					●		Field Installed Only	CMC-29
STD	STD						●	Field Installed Only	CMC-30
STD	STD				●			Field Installed Only	8403-061 ⑤

STD = Standard Equipment

- ① The high & low pressure controls are auto reset. Operating circuit includes a lockout feature and is resettable from the wall thermostat. All low pressure controls use a timed bypass circuit to prevent nuisance tripping during low temperature start-up.
- ② The low ambient control includes an 8201-008 (fan relay) and permits cooling operation down to 0°F.
- ③ PTCR start kit can be used with all -A single phase models. Increases starting torque 2-3x. Not used for -B or -C three phase models. Do not use if SK111 is used.
- ④ Start capacitor and potential relay start kit can be used with all -A single phase models. Increases starting torque 9x. Not used for -B or -C three phase models. Do not use if CMC-15 is used.
- ⑤ ODT. Outdoor thermostat. Field-installed only. Bard Part #8403-061.
Comes with weatherproof enclosure. Works in conjunction with 8403-060 multi-stage thermostats offered by Bard and can be configured for any or all of compressor cut-off in heat pump mode, minimum cooling mode and maximum electric heat operation based on outdoor temperature.
- ⑥ Field installed option for standard units.
- ⑦ Dirty Filter Switch. Adjustable for different filter media. Normally open close-on-activation dry contact rated 1.5A 24VAC. Suitable for use with appropriate thermostat or alarm panels supplied by others.

NOTE: Standard heat pump control board has a 5-minute compressor anti-short cycle timer.

LAC control is required for operation of cooling mode below 55 degrees. This option is recommended for applications throughout most of the United States & Canada.



Bard Manufacturing Company, Inc.
 Bryan, Ohio 43506
 www.bardhvac.com

Due to our continuous product improvement policy, all specifications subject to change without notice.

Before purchasing this appliance, read important energy cost and efficiency information available from your retailer.

**Form No.
 S3459
 April 2019**

Supersedes: S3459-1217